



Falls Irrigation District

Canal Automation Project

Applicant Contact:

Shawn, Tischendorf, District Manager

Falls Irrigation District

310 Valdez St.

American Falls, ID 83211

(208) 226 5227

Fallsirr1@gmail.com

Table of Contents

<i>Technical Proposal and Evaluation Criteria</i>	3
Executive Summary	3
Applicant Information	3
Project Summary	3
Project Location	4
Technical Project Description	5
Evaluation Criteria	6
Evaluation Criteria A – Project Benefits	6
Evaluation Criteria B – Planning Efforts Supporting the Project	9
Evaluation Criteria C – Implementation and Results	10
Evaluation Criteria D – Nexus to Reclamation	11
Evaluation Criteria E – Presidential and DoI Priorities	12
<i>Project Budget –</i>	14
Funding Plan and Letters of Commitment	14
Budget Proposal	14
Budget Narrative	16
<i>Environmental & Cultural Resource Compliance</i>	17
<i>Required Permits and Approvals</i>	18
<i>Official Resolution</i>	20
<i>Appendices</i>	21
Appendix A – Rubicon Quote & Proposed Gate Specifics	21

Technical Proposal and Evaluation Criteria

Executive Summary

Applicant Information

Application Date: 01/14/2025

Applicant Name: Falls Irrigation District

City, County, State: American Falls, Power County, ID

Project Manager:

Shawn Tischendorf, District Manager

Falls Irrigation District

(208) 226-5227

Fallsirr1@gmail.com

Requested Reclamation Funding: \$75,145; **Total Project Cost:** \$150,292.34

Project Summary

Falls Irrigation District (FID) is a Category A applicant. Reclamation owns title to the district (contract No. 14-06-100-851). FID, located in Power County, Idaho, supplies the majority of its water to the 12,621 irrigated acres in the district via a pumping station that pumps water from the American Falls Reservoir into the District's canals. Currently, the lack of automation within their canal results in over deliveries, spillages, and longer hours spent by district staff to manage these issues. The District requests funding assistance through the WaterSMART Small-Scale Water Efficiency Project grant funding program to automate one antiquated check structure on its East Canal. The intent of this project is to keep water in the Snake River for the legitimate purposes of stakeholders, to maintain the water level in the canal for irrigation users, and to improve the efficiency of the District's operations by reducing manual labor and increasing the available data about the canal's performance. If funded, this project would improve the canal's performance by up to 30%, keeping 90 cfs (178 acre-feet / day) of water in the Snake River (American Falls Reservoir) by better matching the availability of water in the East Canal to the demand of its users. This project follows an earlier IWRB-funded project to acquire Variable Frequency Drive pumps at the American Falls Reservoir pump house. When synchronized with the automatic gates in this project, the District will be able to accurately match the demand for East Canal water to the pumps' activity. In addition to the U.S. Bureau of Reclamation WaterSMART project Small-Scale Water Efficiency Project funding, the Falls Irrigation District is pursuing a state grant through the Idaho Water Resource Board. Rubicon Water is the commercial partner. The Falls Irrigation District will work with Rubicon Systems, USA, to perform approximately \$150,000 worth of canal hardware replacement and integration of the District's SCADA system. This proposal is seeking \$75,145 in grant assistance from the Small-Scale Water Efficiency Project funding opportunity, and has already been awarded \$ 40,198 in grant assistance from the Idaho Water Resource Board Aging Infrastructure Program. For this project, FID expects all work to be completed within 15 months of notice to proceed from the Bureau.

Project Location

The Falls Irrigation District canal automation project is located in Power County, within the incorporated portions of American Falls. A general district map with the pump station location is provided below, seen in Figure 1. The specified project location is depicted in the photos, as seen in Figures 2, 3, and 4 below.

The project coordinates are as follows:

- 42°46'17.02"N, 112°51'14.16"W

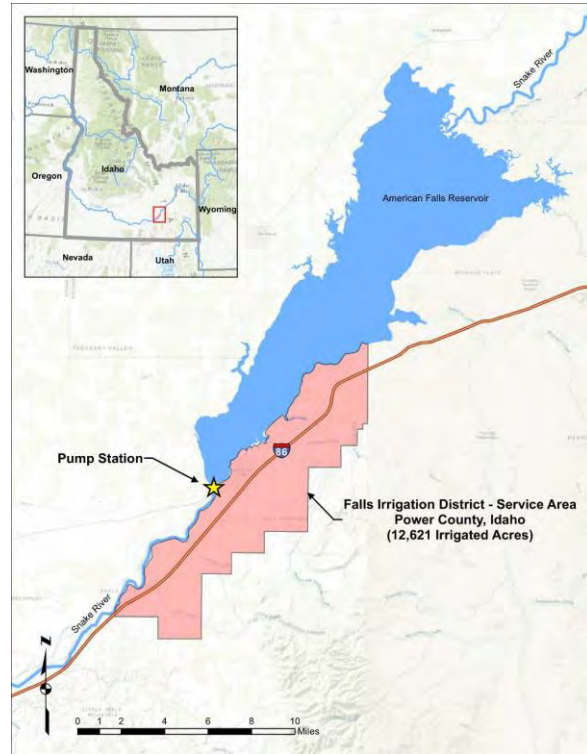

Figure 1 Project Location and District Service Area



Figure 2 Proposed FlumeGate Automation Project Site



Figure 3 Upstream View from Project Site



Figure 4 Downstream View from Project Site

Technical Project Description

Falls Irrigation District (FID) is an Idaho-recognized Title 43 irrigation district in Power County, Idaho. This project would modify a check structure located on Federally-owned property. FID supplies most of its water with 22 miles of canals to 12,621 irrigated acres in the district via a pumping station at the American Falls Reservoir. Currently, the lack of automation within their canal system results in over deliveries, spillages, and longer hours spent by district staff to manage these issues. This project will install two Rubicon FlumeGates at the headworks of the East Canal, leading to better measured and managed water. The FlumeGates would accurately measure flow rates, maintain the canal's water level, and practically eliminate the spills that occur when district staff manually adjust gates and chase the water through the canal. The projected water savings from this project are 10-20%, which will also lead to lower energy costs to power the pumps and pay for the fuel staff use to adjust the water level on the canal. Automating the canals will lead to greater safety and operational efficiency of District staff, improved water measurement and savings, and better service to the FID's customers. Flow data collected from this project will add to FID's understanding of water usage patterns and enable the FID to operate proactively and troubleshoot their system more efficiently.

When functioning in downstream level control, the FlumeGates open to add water and match the optimal water level of the East Canal's users. The Discharge Splitter Basin interacts nearly simultaneously with the VFD pumps to send water and replenish the delivered water. Excluding seepage and evaporation, spills that do occur flow to the American Falls Reservoir for potential reuse.

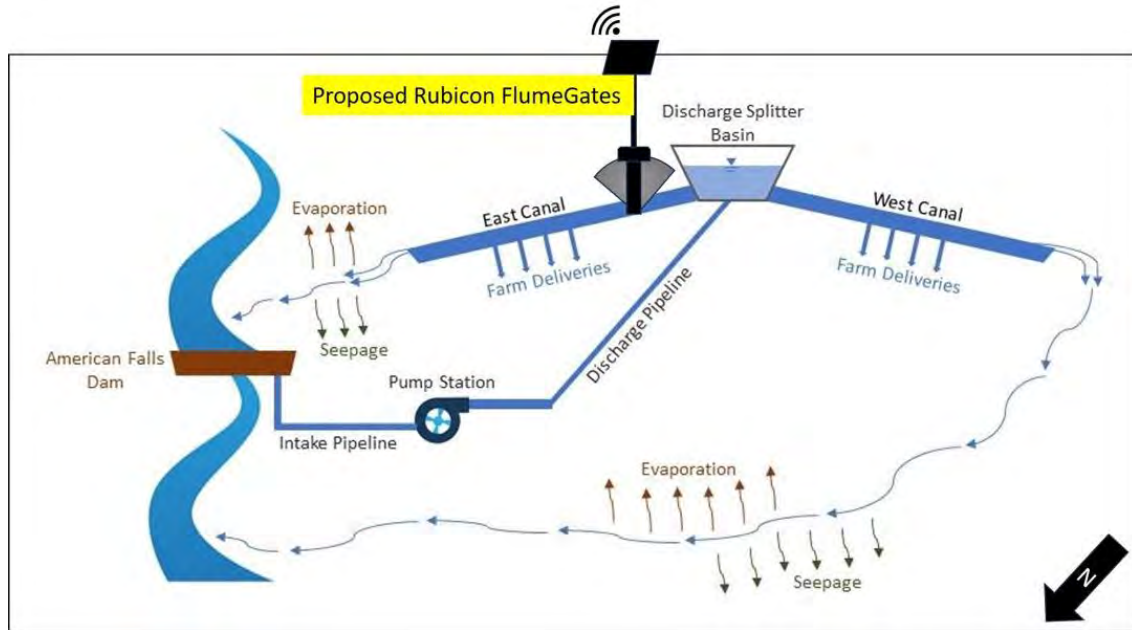

Figure 5 FID Project Concept

Evaluation Criteria

Evaluation Criteria A – Project Benefits

Benefits to the Category A Applicant's Water Delivery System:

- ❖ The FlumeGates would accurately measure flow rates, maintain the canal's water level, and practically eliminate spills that occur when district staff manually adjust gates and chase water through the canal. The projected water savings from this project are 10-20%, which will also lead to lower energy costs to power the pumps and for the fuel staff use by traveling to adjust the water level on the canal. Automating the canals will lead to greater safety and operational efficiency for District staff, improved water measurement and savings, and better service to FID's customers. Flow data collected from this project will add to FID's understanding of water usage patterns and enable the FID to troubleshoot their system more efficiently.
- *Are customers not currently getting their full water right at certain times of the year?*
 - ❖ There are no current restrictions. However, the district may restrict customers' water use during extreme drought. There are frequent water restrictions up to 25% in the fall due to reservoir levels and limitations of the pump station at which point we pro-rate the District's users are pro-rated or adjust their delivery schedules.
- *Does this project have the potential to prevent lawsuits or water calls?*

- ❖ Yes, this project will allow the district to better measure and manage district water at peak and slack times, ensuring the consistent and sustainable delivery of water required to meet stakeholder demand. The proposed automation will help eliminate high and low water calls and potential breaches or losses at the system's end.
- *What are the consequences of not making the improvement?*
 - ❖ Forgoing the proposed improvements will affect the district's ability to prevent overflow, spillages, and water rationing due to variances in flow throughout the water seasons. Additionally, if no updates are made to the project area's flow and water control devices, water throughout the district could continue to be lost through inefficiencies created by a lack of canal control and flow management.
- *Are customer water restrictions currently required?*
 - ❖ There are no current restrictions. However, the district may restrict customers' water use during extreme drought.
- *Other significant concerns that support the need for the project.*
 - ❖ The proposed project's lack of completion will result in continued inefficient water management and delivery within the district due to a lack of precise flow management and delivery tools such as automated gates.

Broader Benefits:

- *Will the project improve broader water supply reliability at the sub-basin or basin scale?*
 - ❖ Benefits are expected to be geographically localized to the district and its stakeholders.
- *Is the project in an area that is experiencing or has recently experienced drought or water scarcity?*
 - ❖ The proposed project is in an area that regularly experiences varying drought conditions. The project sites are located close to the Snake River and the surrounding riparian area, which would see direct benefits from efficient and proper water management.
As seen in *Figures 6 and 7*, Power County, Idaho, where this project would take place, has experienced a varying degree of drought conditions throughout the years. This trend is highly likely to continue in the coming water seasons.

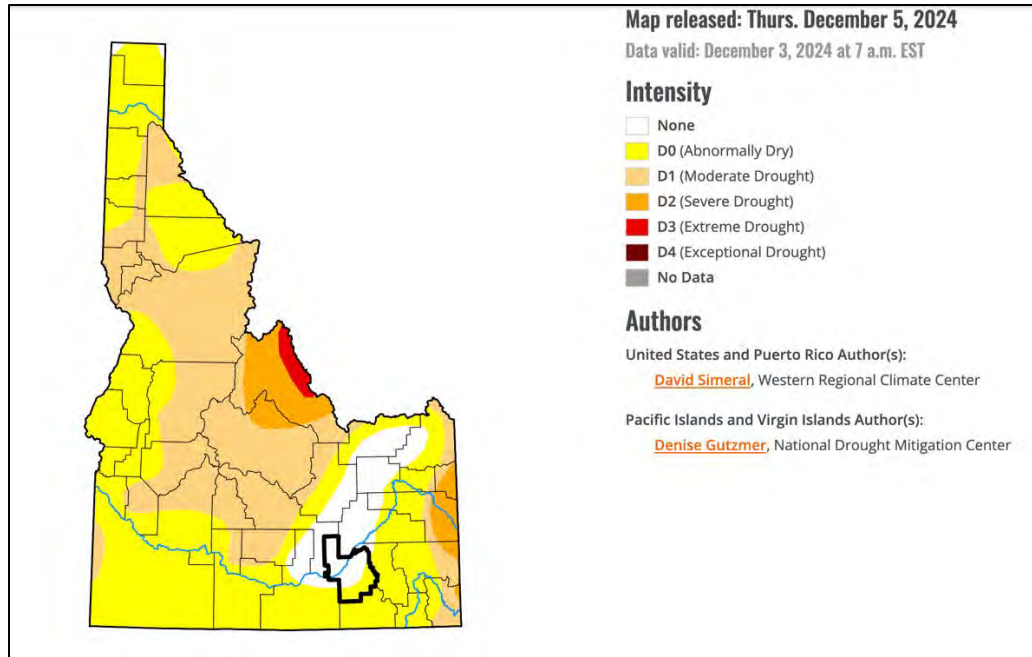

Figure 6 Power County Drought Map

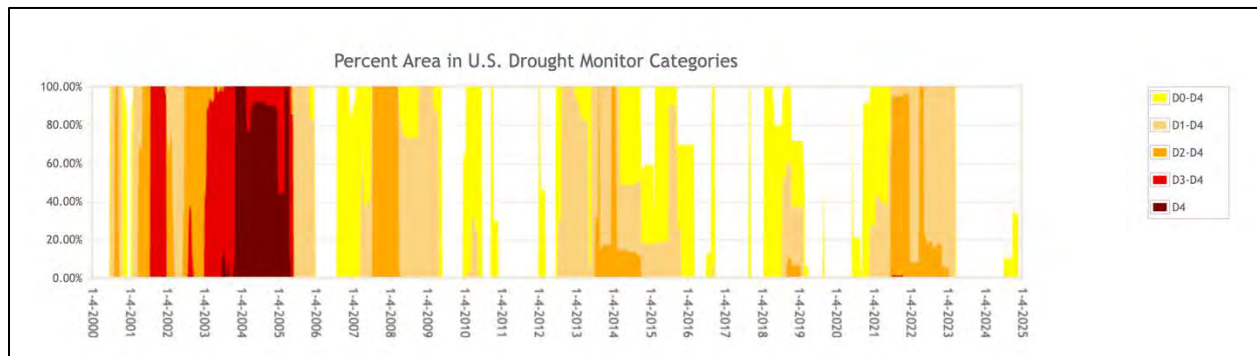

Figure 7 Power County Historic Drought Data

- Will the project benefit species?
 - ❖ Yes. By reducing the amount of water wasted through spillage and inefficient flow management, additional water flows can be left in the river to augment downstream flows to the Snake River, home to some threatened and endangered species, such as the Snake River Sockeye salmon, listed as endangered in 1991, and whose critical habitat was designated in 1993.
[\[https://species.idaho.gov/aquatic-species/sockeye-salmon-snake-river-esu/\]](https://species.idaho.gov/aquatic-species/sockeye-salmon-snake-river-esu/)
- Will the proposed project positively impact/benefit various sectors and economies within the applicable geographic area?
 - ❖ The proposed project will allow more available water to stay in the canal and be returned to the system by reducing water delivery inefficiencies that arise from spillage and over-delivery. Increasing water management efficiency within

the canal allows only the amount needed to be drawn into the canal, avoiding the over-allocation of integral resources. This positively impacts agricultural producers, residential users, and riparian ecosystems by allowing only the water required for service to continue through the district's system. This ensures all stakeholders have access to timely and consistent water deliveries, with no unnecessary over-deliveries, spillages, or losses.

- *Will the project complement work being done in coordination with NRCS in the area?*
 - ❖ This project will not directly benefit any work of this nature.

Evaluation Criteria B – Planning Efforts Supporting the Project

Plan Description and Objectives:

- ❖ The Columbia Basin Climate Change Scenarios Project (CBCCSPP) was conceived as a comprehensive hydrologic database to support climate change planning, impacts assessment, and adaptation in the Pacific Northwest by a diverse user community with varying technical capacity over a wide range of spatial scales^{1,2}. Since the CBCCSPP in 2013, Reclamation referenced it to contribute to the Columbia River System Operations Environmental Impact Statement³. The EIS projected that, due to climate change, inflows to the American Falls reservoir would increase through the spring and decrease through the summer. Additional planning efforts such as Reclamation's 2015 Henry's Fork Basin Study⁴ qualify and quantify the value of water conservation in upper Snake River reservoirs for downstream stakeholders, aquifer recharge, and environmental benefits.

Plan Development:

- ❖ These plans were developed by the Bureau and its stakeholders within the Columbia River Basin as tools for planning and sustainability for the future of the basin's water management and infrastructure.

Support for the Project:

- *Is the project identified specifically by name and location in the planning effort?*
 - ❖ One of the adaptation strategies identified in the study was to increase the flexibility of reservoir operations. By reducing over-delivery and reactive management, this project will help to reduce excess water loss, thereby increasing the volume of water remaining in the system and adding to the flexibility of district operations.
- *Is this type of project identified in the planning effort?*
 - ❖ This type of project is similar to the type of management necessary to implement the adaptation strategies set forth by the study.

¹ <https://warm.atmos.washington.edu/2860/products/sites/?site=2015>

² <https://www.tandfonline.com/doi/full/10.1080/07055900.2013.819555#d1e488>

³ <https://www.nwd.usace.army.mil/CRSO/Final-EIS/#top>

⁴ <https://www.usbr.gov/watersmart/bsp/docs/finalreport/HenrysFork/HenrysForkBasinStudyReport.pdf>

- *Explain whether the proposed project implements a goal or addresses a need or problem identified in the existing planning effort.*
 - ❖ Installing automated gates and SCADA systems supports the sustainable water management necessary to meet the study's goals. The proposed hardware allows for demand-driven water management and would ensure long-term sustainability.
- *Explain how the proposed project has been determined as a priority in the existing planning effort as opposed to other potential projects/measures.*
 - ❖ Upgrading and installing the proposed hardware and SCADA systems supports the long-term sustainable management of the district's water. This is in line with the necessary adaptation strategies stated within the study.

Evaluation Criteria C – Implementation and Results

- This project has six milestones, with the objective of delivering automation to the East Canal in the 2026 irrigation season (see *Figure 8* below).
 - ❖ Milestone 1-IWRB Aging Infrastructure Grant Award was announced in October 2024; Falls Irrigation District's application was selected for funding for this project.
 - ❖ Milestone 2-USBR WaterSMART SWEP Grant Award is expected to be announced in spring 2025. There is some flexibility in the project's schedule to allow for a 90-day delay.
 - ❖ Milestone 3-Production and shipping- The Rubicon gates will begin after the USBR provides the Notice to Proceed (after the initial grant award) to the Falls Irrigation District. Training on the gates' installation, operation, maintenance, and data management can occur concurrently with the production schedule.
 - ❖ Milestone 4-Concrete and labor contracting activities will begin after the USBR provides the Notice to Proceed (after the initial grant award) to the Falls Irrigation District. There is flexibility in the project's overall schedule, but this event must happen after the 2025 irrigation season; No Earlier than 15 October.
 - ❖ Milestone 5-Site construction can begin as soon as the Rubicon gates are ready for final delivery to the Falls Irrigation District and after the contract for the site construction is completed when the 2025 irrigation season ends. Site construction may take up to two weeks.
 - ❖ Milestone 6-Installation of the Rubicon gates may take up to four days. The gates' frames need to be anchored to the sites, the gates installed to the frames, and the gates commissioned before the 2026 irrigation season on or around April 1st 2026.

Falls Irrigation District East Canal Headgates Automation Project	2024											
	Jan	Feb	Mar	Apr	May	Jun	Jul	Aug	Sep	Oct	Nov	Dec
Activity												
FID Irrigation Season												
IWRB Aging Infrastructure Grant Award												
USBR WaterSMART SWEP Grant Award												
Rubicon Gate Production, Shipping, and Training												
Concrete and Labor Contracting Activities												
Site Construction												
Rubicon Gate Installation and Commissioning												
	2025											
Activity	Jan	Feb	Mar	Apr	May	Jun	Jul	Aug	Sep	Oct	Nov	Dec
FID Irrigation Season												
IWRB Aging Infrastructure Grant Award												
USBR WaterSMART SWEP Grant Award												
Rubicon Gate Production, Shipping, and Training												
Concrete and Labor Contracting Activities												
Site Construction												
Rubicon Gate Installation and Commissioning												

Figure 8 Timeline and Milestones

- Describe any permits that will be required, along with the process for obtaining such permits
 - ❖ No additional permits are required for this project, and all work is being done within the district’s right-of-way.
- Identify and describe any engineering or design work performed specifically in support of the proposed project. What level of engineering design is the project currently?
 - ❖ The gates for this project are fabricated off-site and then installed in the retrofitted district facilities.
- Describe any new policies or administrative actions required to implement the project.
 - ❖ After the installation, the timing, measurement, and movement of water will be refined for operational efficiency.
- Does the applicant have access to the land or water source where the project is located? Has the applicant obtained any easements that are required for the project?
 - ❖ Yes, the district has full access to both land and water at the proposed project's locations. All work described and to be performed will be done inside the district’s right of way.
- Environmental Compliance Steps Taken
 - ❖ The cultural review for the project by the district contractor has been performed, completed, and approved by the local USBR offices.

Evaluation Criteria D – Nexus to Reclamation

- The District has a direct nexus to the Bureau of Reclamation. FID was initially established as a Reclamation project in 1955, with contract number 14-06-100-851. Recently, the District finished paying off a loan to purchase the District facilities from Reclamation.

However, Reclamation still holds title to the District because It owns the land on which the District facilities are located.

- *Will the proposed work benefit an existing Reclamation project area or activity?*
 - ❖ The proposed work would benefit the American Falls Reservoir, located within the Columbia River Basin. The proposed automation will decrease the amount of over-pumping occurring and allow the district to operate sustainably without excess water being pumped from the reservoir. When functioning in downstream level control, the proposed FlumeGates will open to add water and match the optimal water level of the East Canal’s users. The Discharge Splitter Basin will near-simultaneously interact with the VFD pumps to send water and replenish the delivered water. Excluding seepage and evaporation, the spills that do occur will flow to the American Falls Reservoir for potential reuse.

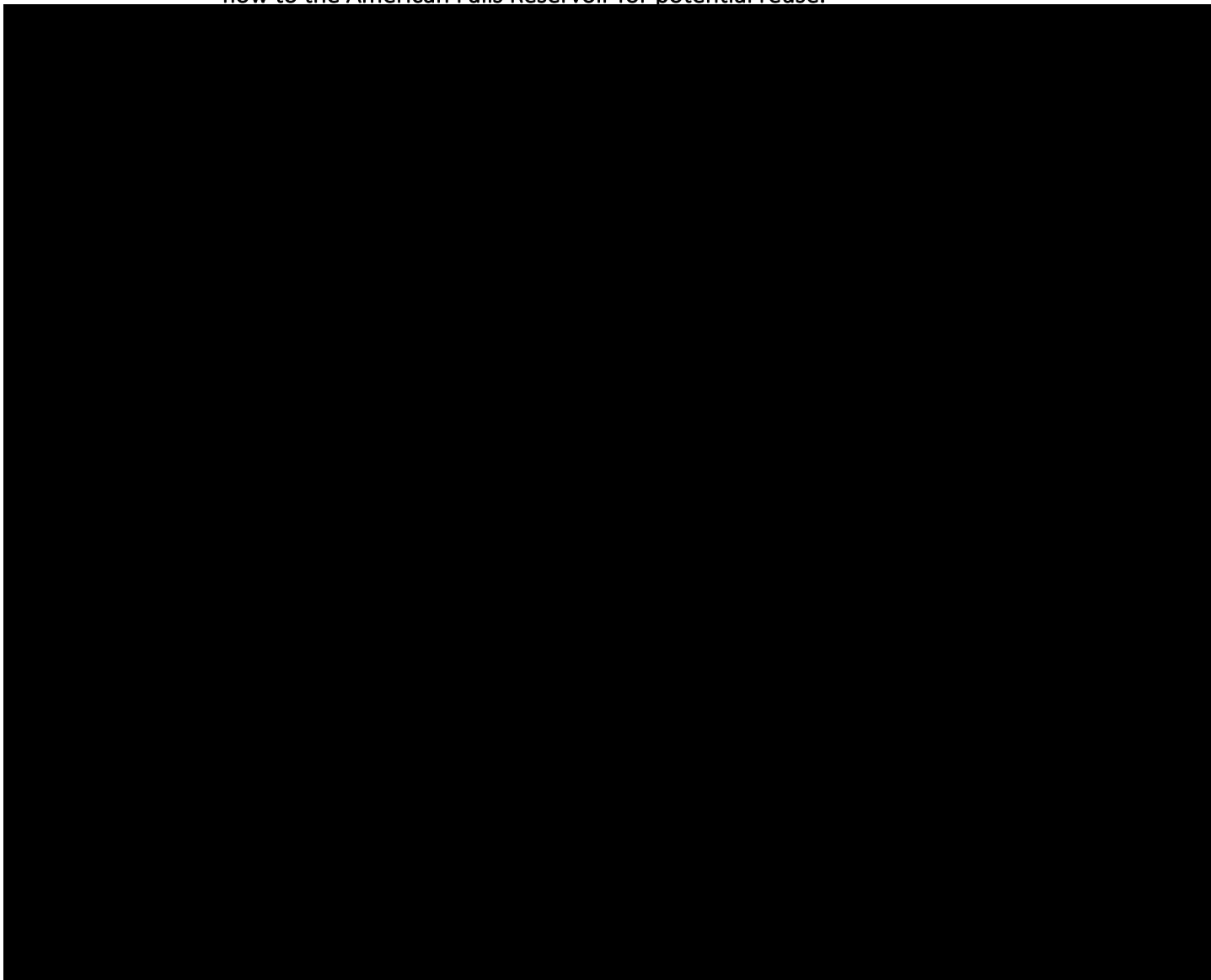

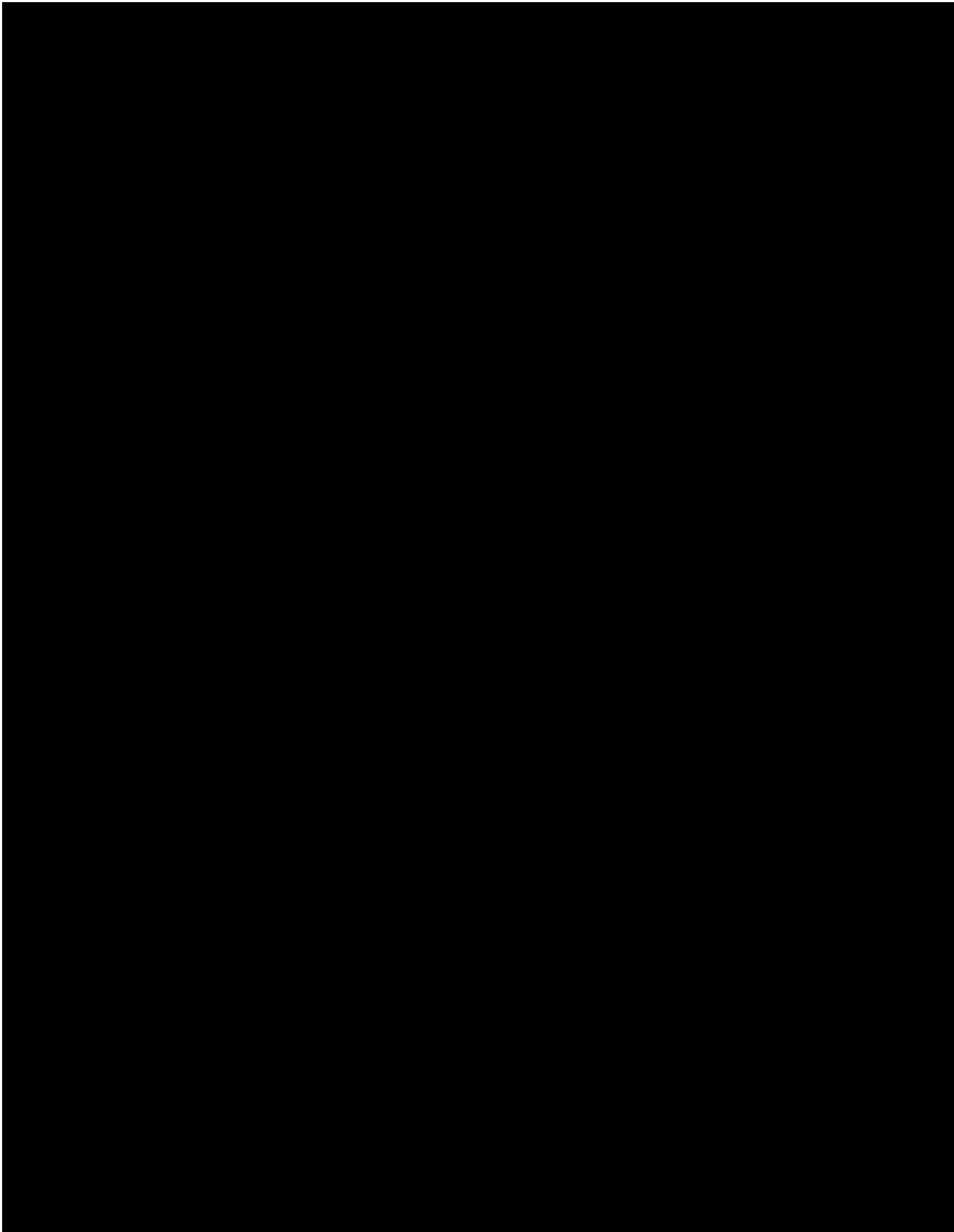

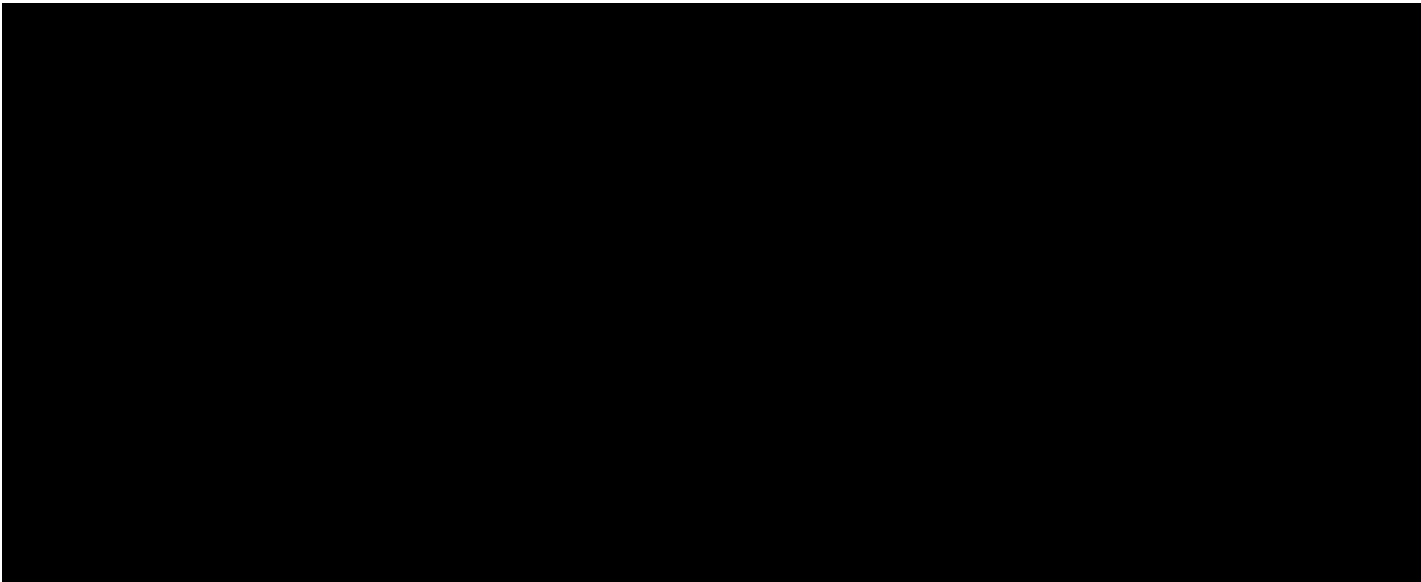

Project Budget – Funding Plan and Letters of Commitment

Please identify the sources of the non-Federal cost-share contribution for the project, including:

- Any monetary contributions by the applicant towards the cost-share requirement
 - ❖ Falls Irrigation District plans to contribute \$34,092.34 to the total project cost from the district’s O&M account.
- Any costs that will be contributed by the applicant
 - ❖ None Expected.
- Any third-party in-kind costs (i.e., goods and services provided by a third party)
 - ❖ None Expected.
- Any cash requested or received from other non-Federal entities
 - ❖ FID has been awarded grant assistance from the Idaho Water Resource Board (IWRB) through the Aging Infrastructure funding opportunity, contributing \$40,198 to the total project cost.
- Any pending funding requests
 - ❖ None.

Budget Proposal

Table 1.—Summary of Non-Federal and Federal Funding Sources

FUNDING SOURCES	AMOUNT
Non-Federal Entities	

1. Falls Irrigation District	\$34,948.34
2. Idaho Water Resource Board	\$40,198.00
Non-Federal Subtotal	\$75,147.34
REQUESTED RECLAMATION FUNDING	\$75,145.00

Table 2. —Total Project Cost Table

SOURCE	AMOUNT
Costs to be reimbursed with the requested Federal funding	\$75,145.00
Costs to be paid by the applicant	\$34,948.34
Value of third-party contributions	\$40,198.00
TOTAL PROJECT COST	\$150,292.34

Table 3. —Budget Proposal Mid Canal Automation

BUDGET ITEM DESCRIPTION	COMPUTATION		Quantity	TOTAL
	\$/Unit	Quantity	Type	COST
Salaries and Wages				
Project Manager	\$32.56	100	Hours	\$3,256.00
Operations Lead	\$19.50	55	Hours	\$1,072.50
Operator	\$17.92	55	Hours	\$985.60
Crew Member	\$17.00	55	Hours	\$935.00
Fringe Benefits				
Included in rates shown	Labor Costs	265		\$6,249.10
Contractual/ Construction				
Environmental Compliance	\$5,500.00	1	Invoice	\$5,500.00
FID Equipment				
318 Excavator	\$74.68	15	Hours	\$1,120.20
Mini Excavator	\$22.40	20	Hours	\$448.00
1-Ton Truck	\$53.40	40	Hours	\$2,136.00
½-Ton Truck	\$34.95	40	Hours	\$1,398.00
Truck Chassis & Dump Bed	\$72.89	15	Hours	\$1,093.35
Concrete Saw	\$3.19	15	Hours	\$47.85
Supplies and Materials				
Gate East Canal Headgates	\$41,444.00	2	Units	\$82,888.00
Walkways for Gates	\$1,966.00	2	Units	\$3,932.00

Gate Installation, Supervision, and Commissioning	\$2,350.00	2	Units	\$4,700.00
SCADA Service Agreement	\$1,500.00	1	Units	\$1,500.00
Other				
Incidentals			Incidental costs incurred throughout project	\$22,792.24
TOTAL DIRECT COSTS				\$140,53.84
Indirect Costs				
Shipping		\$10,000.00		\$10,000.00
Office Manager	\$23.85	10	Hours	\$238.50
TOTAL INDIRECT COSTS				\$10,238.50
TOTAL PROJECT COSTS				\$150,292.34

Budget Narrative

Salaries and Wages & Fringe Benefits

The certified current rates of pay for the project manager, operations lead, and crew are the rates listed in the budget proposal. These salaries are applied consistently to all federal and non-federal activities of FID. The fringe benefits are the district’s portion of employee benefits costs.

Travel, Equipment, Materials & Supplies, Other Expenses & Indirect Costs

There is no travel authorized for this project nor included in the budget proposal. All equipment to be used on this project is owned by FID or will be purchased by FID. Therefore, the equipment budget is shown as an in-kind contribution by FID as if it were owned by FID. The rates in the budget proposal are in accordance with the USACE equipment rates for the region. The time estimate for each piece of equipment was determined from the average usage on similar past District projects. The materials and supplies listed in the budget proposal are all for construction efforts related to the gate site prep and installation. The costs for materials were estimated from budgetary quotes obtained from distributors and past District projects. The total listed as incidental is for unforeseen expenses that might arise, such as small electrical components, wire, freight, or tools that might break. The indirect cost represents Idaho state and local sales taxes and clerical staff time to prepare reports and track project expenses. The clerical staff hourly rate shown in the budget proposal includes the fringe benefits.

Environmental/Regulatory Compliance Costs, Contractual/Third-Party In-Kind Contributions

Environmental compliance has been completed. An invoice from this activity can be provided upon request. This project does not expect any other contractual expenses, and the district does not anticipate any contributions matching this description.

Environmental & Cultural Resource Compliance

- *Will the proposed project impact the surrounding environment*
 - ❖ **No, the project will not have any of these effects. There will be limited dust from concrete cutting in the initial phase, and the district will hold normal working hours on site every day.**
- *Are you aware of any species listed or proposed to be listed as a Federal threatened or endangered species or designated critical habitat in the project area?*
 - ❖ **The district is not aware of any such species within the proposed project areas.**
- *Are there wetlands or other surface waters inside the project boundaries that potentially fall under CWA jurisdiction as “Waters of the United States”?*
 - ❖ **This project will benefit CWA jurisdiction, “Waters of the United States”, as it will conserve water, thereby leaving more water in the river and reservoirs.**
- *When was the water delivery system constructed?*
 - ❖ **Falls Irrigation District's water delivery system was constructed in the late 1950s.**
- *Will the proposed project result in any modification of or effects to, individual features of an irrigation system (e.g., headgates, canals, or flumes)? If so, state when those features were constructed and describe the nature and timing of any extensive alterations or modifications to those features completed previously.*
 - ❖ **The project will add automation apparatuses to existing structures, which were first constructed in the 1950s.**
- *Are any buildings, structures, or features in the irrigation district listed or eligible for listing on the National Register of Historic Places?*
 - ❖ **There are no sites within the project area that are listed.**
- *Are there any known archeological sites in the proposed project area?*
 - ❖ **No, there are no known archeological sites within the proposed project area.**
- *Will the proposed project have a disproportionately high and adverse effect on low-income or minority populations?*
 - ❖ **No, the project will not have any disproportionately high adverse effects on low-income or minority populations.**
- *Will the proposed project limit access to and ceremonial use of Indian sacred sites or result in other impacts on tribal lands?*
 - ❖ **No, the project will not contribute to any of the above-mentioned impacts to tribal sacred sites or tribal lands.**
- *Will the proposed project contribute to the introduction, continued existence, or spread of noxious weeds or non-native invasive species known to occur in the area?*
 - ❖ **No, the proposed project will not contribute to this.**

Required Permits and Approvals

There are no expected additional permits required for this project.

Official Resolution

**Official Resolution
Of the
Falls Irrigation District
Resolution No. 2024-01**

Whereas, The U.S. Bureau of Reclamation is seeking proposals from irrigation districts who want to leverage their money and resources in partnership with Reclamation to conserve and use water more efficiently through the WaterSMART: Small Scale Water Efficiency Project FY24.

Whereas, The Falls Irrigation District has a need to improve water levels in the diversion pond to keep delivery accurate, and reliable for FID waterusers. FID plans to install and use Rubicon's self-adjusting flume gates on the head of the East Main Canal to keep diversion pond levels accurate and conserve water.

Whereas, The Falls Irrigation District desires to apply for funding for Diversion Pond Automation Project through Reclamation's WaterSMART Grant Program:

Now Therefore Be It Resolved, that the Board of Directors of the Falls Irrigation District agree and authorize the following:

1. The Board has reviewed and supports the Grant Application Submitted;
2. The Falls Irrigation District is capable of providing the amount of funding and/or in-kind contributions as specified in the funding plan; and
3. If selected for the WaterSMART Grant, the Falls Irrigation District will work with Reclamation to meet the established deadlines by entering into a cooperative agreement.

Passed and adopted by the Board of Directors of the Falls Irrigation District during a regular board meeting on the 12th day of June, 2024.

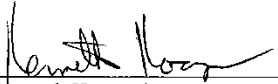

Kenneth Koopin
President, Falls Irrigation District

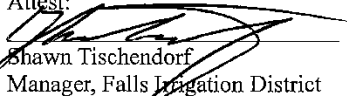
Attest:

Shawn Tischendorf
Manager, Falls Irrigation District

Appendices

Appendix A – Rubicon Quote & Proposed Gate Specifics



QUOTE

Date: June 25, 2024

To: Shawn Tischendorf
Company: Falls Irrigation District
Address: 310 Valdez St
American Falls, ID 83211
Phone: (208)226-5227
Email: Fallsirr1@gmail.com
Quote #: Q502038
Project: East Canal Headworks
Valid For: 60 days
Shipping terms: FOB Modesto, CA
Billing terms: Net 30 days (see Payment Terms for details)
Prepared by: Michael Bromund
Mobile: (509) 481-0571
Email: michael.bromund@rubiconwater.com

Rubicon Water

Rubicon Systems America, Inc.

Fort Collins

1501 S. Lemay Avenue
Suite 101

Fort Collins, CO 80524

toll free 1-877-440-6080

phone 970-482-3200

fax 970-482-3222

email inquiry@rubiconwater.com

Modesto

2318 Terway Drive

Modesto, CA 95354

Imperial

415 W Ater Road

Imperial, CA 92251

www.rubiconwater.com

Dear Shawn

As requested, please see below the quote for the East Canal Headworks at 42°46'17.02"N, 112°51'14.16"W.

Regards,

Mike Bromund



Pricing:

Qty	Product	Product Model	Description	FY24 Unit Price (US\$)	Total (US\$)
2	FlumeGate	FGB-1050-1804	Rubicon FlumeGate, designed for a nominal install width of 48" and a fully closed checking height of 68". Maximum submerged flow is 79 CFS, max freeflow is 127 CFS. Fully integrated solution.	\$41,444	\$82,888
2	FlumeGate Walkway	WW-1180-M-BEE	Rubicon FlumeGate Walkway. Suits 54" structure wide FGs.	\$1,966	\$3,932
1	Software	SiteConnect Live	SiteConnect Live Starter Kit (includes a cellular modem, antenna, cabling), as well as account and site configuration on Rubicon's cloud-based SCADA system. One-time fee.	\$1,000	\$1,000
1	Software	SiteConnect Live	SiteConnect Live, Control Site - Annual subscription fee, per site. Includes cloud hosting and cellular service.	\$500	\$500
2	Service	Supervision & Commissioning	Supervision & Commissioning Per Gate (2 gates)	\$2,350	\$4,700
Total (Excluding Taxes)					\$93,020

FlumeGate® Description:

Each FlumeGate includes the following items:

- The FlumeGate is a combination automated overshot control gate and flow measurement device that mounts in new or existing structures, and arrives as a complete turnkey installation.
- Each FlumeGate comes equipped with a control pedestal which includes a standard processor and keypad for automation (for remote mounting), solar panel power system and a 16 ft mast for mounting of a communication antenna; one aluminum external mounting frame, c/w stainless steel anchors, Hilti epoxy and SIKA sealant.
- Included is one (or more) 12-volt DC deep cycling battery pack; each pack consists of two or more batteries. Note, the batteries must be removed from the meter and charged if the gates are not installed within four weeks of delivery;
- One set of primary ultrasonic water level sensors (long range);
- Standard Rubicon local flow and level software (level control requires tuning, added charge).
- Options include an operator walkway to span the gate, attached to the top beam, with access from one or both sides.

SCADAConnect Live Description:

Rubicon's SCADAConnect Live is a cloud-based SCADA system that gives users full remote control of their sites. Data is transmitted through AT&T's cellular network to both send commands to the sites as well as gather all data, including flows, levels, alarms etc. Included in SCADAConnect Live:

- Full remote monitoring and control of sites. Note access can be varied depending on password for different officers of the irrigation district (full control versus monitoring only).
- Alarming functions can be sent through email or text.
- All data pertinent to each site can be viewed on the site's historian, or downloaded in .CSV format for storage or reporting.

Rubicon Water

Confidential

Quote # Q502038

Page 2



Note regarding SCADA / Remote Connectivity:

Automated devices are designed to provide continuous operation without human intervention. However, remote connectivity is a feature available on all Rubicon gates and meters that enhances the manageability of the device, giving operations team 24/7 live access in order to better manage the system. As is the case in any automated system, electro-mechanical systems can be subject to upsets beyond their control that require human intervention. For this reason, Rubicon offers SCADACONnect Live as a means for cost-effective remote monitoring and control in order to ensure proper canal operations, and prompt notification in the event of concerning situations. In the event you are not interested in Rubicon's SCADA offering, we would still highly recommend the implementation of some means of remote monitoring to ensure adversity can be met swiftly before serious problems arise.

Supervision & Commissioning:

Services during commissioning include:

- Site visits by a Rubicon certified Field Technician. The visits will involve mounting of the external frame, supervising the lifting of the gate into the frame, commissioning and training in the operation and maintenance of the meter.
- The customer is responsible for ensuring a safe worksite, adhering to all relevant federal, state, and local regulations, including OSHA and Cal/OSHA standards where applicable. Non-compliance may lead to delays in project completion, and any additional costs incurred by Rubicon due to such delays may be charged to the customer.

Exclusions:

- Installation Labor to be completed by third party/client for field installation of the meter gate.
- Civil works to structures to fit above gate.
- Supply and operation of crane for install of meter gate – if required.
- Dewatering of site for installation:
 - It is expected that the site will be dry and clean for installation of external frames. If the Rubicon Technician finds that there is water on the site the day of the scheduled external frame installation, the client will pay for the additional day of labor lost.

Payment Terms:

Payments are to be made as follows:

- Net 30 days.
- Spare parts will be invoiced 100% when shipped.
- In the event that frames and meter/gate hardware are shipped separately, payment is to be made as follows:
 - 30% of the total price within 30 days of shipment of frames.
 - 70% of the total price within 30 days of the delivery of the meter/gate hardware.

All payments are to be made by check to Rubicon Systems America Inc.

Warranty:

Rubicon Water warrants the hardware offered in this quotation to be free of defects in material and workmanship for a period of twelve months from the date of commissioning.

Warranty on spare parts is twelve months from delivery. Rubicon Water Standard Terms of Sale applies to this Quotation and is appended to the end of this quotation.

Rubicon Water

Confidential

Quote # Q502038

Page 3



Delivery:

All hardware will be delivered by road transport to customer worksite, whereupon immediate unloading will be the responsibility of customer. Rubicon will not be responsible for any damage that may occur at the customer worksite.

It is anticipated the gates and associated hardware will be delivered to customer within 20-25 weeks upon receipt of a Purchase Order but will be confirmed by email once the order has been received. However, lead times may vary; your sales person can give you an updated lead time upon the submission of your order.

Note the delivery lead time noted above is for shipment of hardware to the customer site and does not include installation site work. Installation and commissioning are scheduled separately by Rubicon's Operations team and is dependent on team availability and acceptable weather conditions.

The Next Step:

To accept this quotation and begin the procurement process, please sign here and return. **NOTE:** In order to accept this quotation as a purchase order, the below needs to be signed and dated by an officer of the company with purchasing authority, and all pages of the quotation and Terms & Conditions must be included.

Customer:

Authorized Signature

Date

Authorized By:

On Behalf of North American General Manager

FlumeGate™



Overview

The FlumeGate is a combined flow measurement and control gate designed for open canal applications. Accurate flow measurement, precise motor control, power supply and radio telecommunications are fully integrated in a single device.

In free-flow or submerged conditions, flow is calculated from the gate's own measurements of upstream water level, downstream water level and gate position. The FlumeGate can be operated as a stand-alone unit, or can coordinate with other gates along the canal to optimize the whole network's flow. It can be managed and monitored on-site or operated remotely when connected to a SCADA network.

The FlumeGate automatically controls the flow of water by varying the gate position based on a desired set-point or on irrigation demand as shown in the table.

Control objective	Gate action	
Local	Position	Moves to a desired set-point and stays there
	Flow	Maintains a constant flow regardless of upstream or downstream levels
	Upstream level	Maintains a desired water level in the pool immediately upstream
	Downstream level	Maintains a desired water level in the pool immediately downstream
Network¹	Supply	Changes the flow to match the flow supplied from the network above the gate while maintaining a stable upstream water level
	Demand	Changes the flow to match measured outflow from the network below the gate while maintaining a stable downstream water level

¹ Network control is only available when used with other Rubicon gates and Rubicon's NeuroFlo™ network control software.

A TCC™ product

The FlumeGate is one of the products making up a modular family of precision hardware and software called TCC (Total Channel Control™). TCC is an advanced technology set designed to improve the management and productivity of water in open canal and gravity pipeline distribution. TCC products can interact and work together to help managers improve:

- water availability
- service and equity to users
- management and control
- canal operator safety



Features

- Ultrasonic water level measurement
- Integrated flow calculation and control software
- Solar-charged or 120V AC charged battery system
- SCADA ready communication system
- Robust high duty cycle operation
- Overshot design for better water level control
- Optional walkways with handrails for staff safety

Ideal solution for ...

- Headgates, turnouts, or check structures requiring low headloss
- Gate modernization projects (more cost-effective than automating an existing gate)
- Remote locations without AC power
- Maintaining canal diversions or upstream water levels
- Measuring flow in canal-to-siphon applications



Data Sheet

FlumeGate™

Control Pedestal

Each FlumeGate installation includes a robust pedestal that provides power and control to the gate and is a secure, weatherproof housing for electronic components and batteries.

The pedestal also serves as a local user interface. A keypad and LCD display are located under a lockable lid, allowing secure access for authorized users to monitor, control and troubleshoot on-site.

High strength construction

FormiPanel™ is Rubicon's high strength gate leaf construction that uses techniques adopted from the aerospace and marine industries.

The gate panel assembly is a laminate construction that utilizes high strength industrial adhesives to bond structural grade aluminum extrusions and skin plates to a synthetic core material. The result is strong, lightweight, and corrosion resistant.

Flow measurement

The FlumeGate calculates flow using measurements of upstream water level, downstream water level and gate position, achieving independently verified measurement accuracy of $\pm 2.5\%$. This accuracy is attributed to its unique design and precision manufacture.

Rubicon's MicronLevel™ water level measurement sensors are housed within the internal frame. A water-tight seal separates the upstream and downstream sensors.

- Unique, integrated stilling wells unaffected by surrounding objects, debris, foam, silt or other contaminants
- Self-calibrates on every reading to eliminate drift in speed of sound due to changes in temperature or humidity
- Specifically designed for use in harsh irrigation canal environments



Local user interface

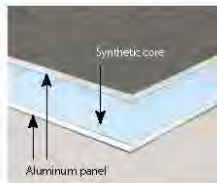

FormiPanel™ construction



SCADAConnect™ Software

Gate control technology

CableDrive™ is Rubicon's actuation system, designed to provide precision gate position accuracy and repeatability in harsh environments. The drive is a wire rope (cable) and drum mechanism that provides positive drive in both the raise and lower directions. It is designed for high duty cycle operation and provides precise gate positioning to within ± 0.02 in (0.5mm).

The drive is managed by Rubicon's SolarDrive™ technology – a purpose-built integrated circuit board that manages gate positioning, solar power regulation, battery charge and the pedestal user interface.

Low maintenance

The FlumeGate's modular design allows it to be maintained in the field with minimal tools, training, and easily replaceable parts.

- Level sensors are easily removed during in-field servicing
- Seals can be replaced
- On-site diagnostics
- Service can be done by local Rubicon field technicians or authorized/trained independent local integrators

Easy to install

Rubicon's FlumeGate products are designed to retrofit to existing check type regulating structures as well as purpose built emplacements significantly reducing costs associated with civil work.

- Installed and operational in two days during irrigation or off-season
- Factory calibrated and pre-commissioned

Frame corner section



Sensor detail

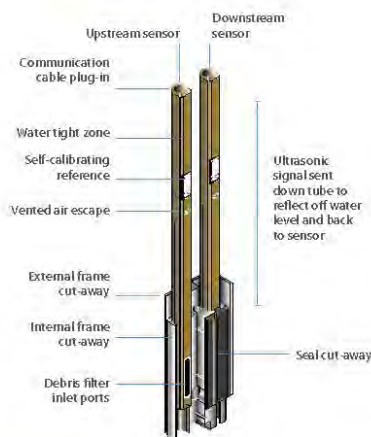

Sensor location

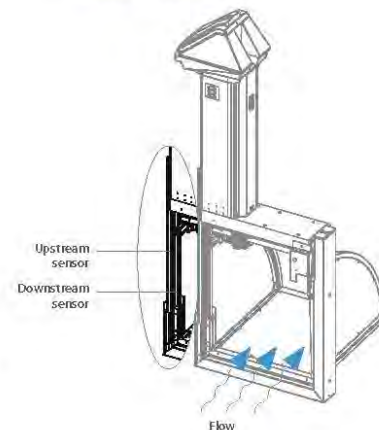

Data Sheet



FlumeGate™ components

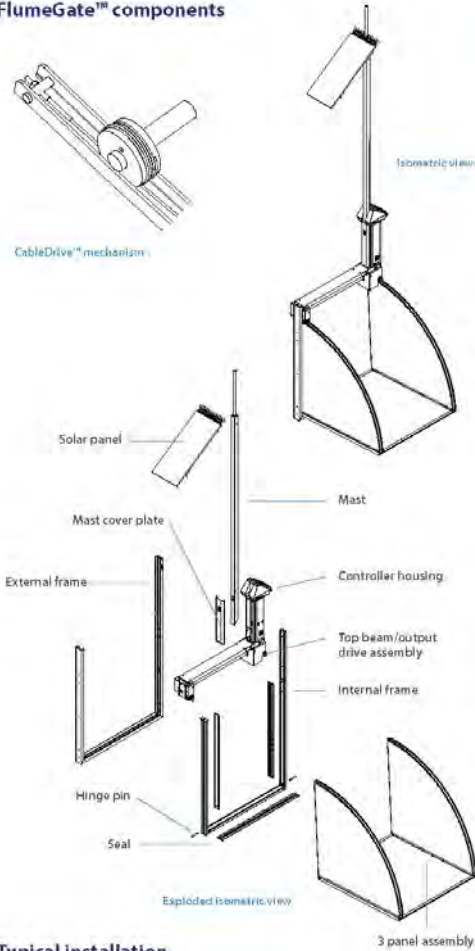

Typical installation

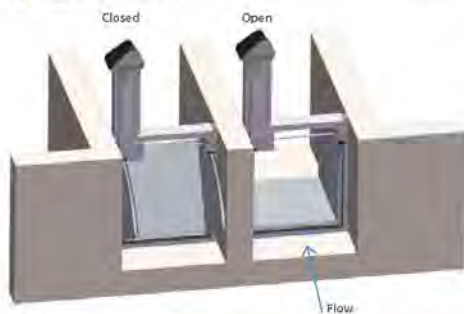

FlumeGate™ specifications

General	
User interface	LCD screen
Data interface	RS232/485, USB, Ethernet, Protocols – DNP3, MDLC, Modbus, TCP/IP, others
Local interface language	English, Spanish, French, Chinese and Italian (metric/imperial units)
Data tags	A comprehensive set of tags are available for integration into SCADA systems
Data storage	Historical data can be uploaded locally via USB for post processing.
Control	Local or remote via SCADA
Drive mechanism	CableDrive™ stainless-steel wire rope and cable drum assembly for precision positioning and long life
Electronics	SolarDrive™ power management and control technology housed in the local Control Pedestal. Each unit passes a 12hr heat soak pre-stress and 100% functional test.
Gate actuation	12V DC motor with 256 count magnetic encoder, with mechanical and electrical override provisions
Power supply options	12V DC powered (solar), 120V AC powered
Seal performance	Less than 0.1 gallons/minute/foot of seal (exceeds AWWA C513)
Flow measurement	
Technique	Flow rate calculated from measurements of upstream water level, downstream water level and gate position, using data-derived flow measurement algorithm.
Measurement rate	10 seconds
Accuracy	±2.5%, ² Accuracy of FG-M-626-620 model verified by Manly Hydraulics Laboratory, August 2005.
Calibration method	Factory pre-calibrated and internal self-calibrating sensors. Simple in-field verification process.
Water level measurement	
Technique	Ultrasonic
Accuracy	0.02in (0.5mm)
Resolution	0.004in (0.1mm)
Material	
Frames	Extruded marine grade aluminum
FormiPanel™	Rubicon's marine grade aluminum composite laminate gate panel
Corrosion protection	Marine grade aluminum and stainless steel materials designed for typical irrigation water applications. A polyamine-cured epoxy coating is available for additional protection against chemical corrosion. ³ Please consult you Rubicon sales engineer.
Hardware and shafts	Stainless steel
Seals	EDPM rubber
Hinge	Duplex stainless steel
Water level sensors	Anodized marine grade aluminum and copolymer acetyl plastic with stainless steel fittings.
Standards	All materials compliant with relevant US standards
Power	
Power supply	12V DC self-contained battery charged from solar panel or AC line power
Batteries	Sealed gel lead acid with temperature sensor (~5yr life, provides ~5 days of operation without solar or AC line power) or optional lithium LiFePO4.

Specifications subject to change



Dimensions and operating ranges

Model	Frame width	Weight	OL	CE, HUm _{ax}	ΔH _{min}	Q _F	Q _S	Q _S ΔH _{min}
Aortic	Imperial		in	in	in	cfs	cfs	cfs
FG-0625-0674	FG-2½-2.3	220	4.9	28.1	1.6	1.8	1.3	1.2
FG-0625-0866	FG-2½-2.9	254	5.3	34.6	1.6	2.5	1.8	1.6
FG-0625-1077	FG-2½-3.4	353	6.3	40.7	1.9	3.0	2.1	1.9
FG-0625-1273	FG-2½-4.0	408	6.5	48.4	2.3	4.3	2.9	2.7
FG-0760-0866	FG-3-2.9	265	5.3	34.6	1.6	3.1	2.2	2.0
FG-0760-1077	FG-3-3.4	375	6.3	40.7	1.9	3.8	2.6	2.4
FG-0760-1273	FG-3-4.0	430	6.5	48.4	2.3	5.4	3.6	3.4
FG-1050-0674	FG-4-2.3	254	4.9	28.1	1.6	3.1	2.3	2.1
FG-1050-0866	FG-4-2.9	342	5.3	34.6	1.6	4.2	3.0	2.7
FG-1050-1077	FG-4-3.4	408	6.3	40.7	1.9	5.4	3.8	3.5
FG-1050-1273	FG-4-4.0	496	6.5	48.4	2.3	7.8	5.2	4.9
FG-1092-1437	FG-4-4.5	551	7.5	54.5	2.6	9.2	6.0	5.9
FG-1092-1587	FG-4-5.0	694	7.9	60.4	3.0	10.7	6.8	6.8
FG-1092-1804	FG-4-5.5	772	7.7	67.7	3.4	12.7	* 8.1	
FG-1180-0866	FG-4½-2.9	364	5.3	34.6	1.6	4.8	3.4	3.1
FG-1180-1077	FG-4½-3.4	419	6.3	40.7	1.9	6.2	4.3	3.9
FG-1180-1273	FG-4½-4.0	507	6.5	48.4	2.3	8.8	5.9	5.6
FG-1180-1437	FG-4½-4.5	562	7.5	54.5	2.6	10.5	6.8	6.7
FG-1180-1587	FG-4½-5.0	717	7.9	60.4	3.0	12.2	7.8	7.8
FG-1180-1804	FG-4½-5.5	805	7.7	67.7	3.4	14.4	* 9.2	
FG-1370-0674	FG-5-2.3	320	4.9	28.1	1.6	4.0	3.0	2.7
FG-1370-0866	FG-5-2.9	386	5.3	34.6	1.6	5.6	4.0	3.6
FG-1370-1077	FG-5-3.4	441	6.3	40.7	1.9	7.2	5.0	4.6
FG-1370-1273	FG-5-4.0	528	6.5	48.4	2.3	10.4	6.9	6.6
FG-1370-1437	FG-5-4.5	595	7.5	54.5	2.6	12.3	8.0	7.8
FG-1370-1587	FG-5-5.0	739	7.9	60.4	3.0	14.4	9.2	9.1
FG-1370-1804	FG-5-5.5	827	7.7	67.7	3.4	17.0	* 10.9	
FG-1485-0620	FG-5½-2.0	287	4.1	24.2	1.6	3.8	2.9	2.6
FG-1485-1077	FG-5½-3.4	452	6.3	40.7	1.9	7.9	5.5	5.0
FG-1485-1273	FG-5½-4.0	551	6.5	48.4	2.3	11.3	7.5	7.2
FG-1485-1437	FG-5½-4.5	705	7.5	54.5	2.6	13.2	8.6	8.4
FG-1485-1587	FG-5½-5.0	761	7.9	60.4	3.0	15.7	10.0	10.0
FG-1485-1804	FG-5½-5.5	849	7.7	67.7	3.4	18.5	* 11.9	
FG-1675-0674	FG-6-2.3	353	4.9	28.1	1.6	5.0	3.7	3.3
FG-1675-0866	FG-6-2.9	419	5.3	34.6	1.6	7.0	5.0	4.5
FG-1675-1077	FG-6-3.4	507	6.3	40.7	1.9	9.0	6.2	5.7
FG-1675-1273	FG-6-4.0	573	6.5	48.4	2.3	12.8	8.5	8.2
FG-1675-1437	FG-6-4.5	728	7.5	54.5	2.6	15.6	9.6	9.6
FG-1675-1587	FG-6-5.0	794	7.9	60.4	3.0	17.6	11.4	11.4
FG-1675-1804	FG-6-5.5	882	7.7	67.7	3.4	21.1	* 13.5	
FG-1675-2186	FG-6-7.2	1598	15.4	86.6	4.1	27.0	* 17.3	
FG-1675-3038	FG-6-9.5	2646	18.7	114.6	5.6	39.0	* 25.0	
FG-1790-1077	FG-6½-3.4	529	6.3	40.7	1.9	9.6	6.7	6.2
FG-1790-1587	FG-6½-5.0	757	8.05	7.9	60.4	3.0	19.1	12.2
FG-1790-2186	FG-6½-7.2	1631	13.4	86.6	4.1	29.1	* 18.6	
FG-1960-3038	FG-7-9.5	832	31.97	18.7	114.6	5.6	47.6	* 30.5
FG-2268-1587	FG-8-5.0	1543	10.2	60.4	3.0	23.3	14.4	14.3
FG-2268-2186	FG-8-7.2	946	17.20	12.4	86.6	4.1	37.7	* 24.1
FG-2268-3038	FG-8-9.5	3086	18.7	114.6	5.6	55.7	* 35.7	
FG-2886-1587	FG-10-5.0	1189	16.53	10.2	60.4	3.0	28.9	18.6

The dimensions above are for reference purposes only and may change over time. Contact Rubicon for complete dimensions and flow rating tables. Consultation with a Rubicon sales engineer is recommended prior to gate sizing. Weights are approximate.

* The ΔH_{min} value for this model FlumeGate is higher than the 3in specified in the Q_S calculation, please refer to the Q_SΔH_{min} value.

† Painted polyamine-cured epoxy coating is available for protection against chemical corrosion. This option is denoted by a-P added to the model numbers when ordering, eg. FGB-2268-2186-P.

Side and plan views

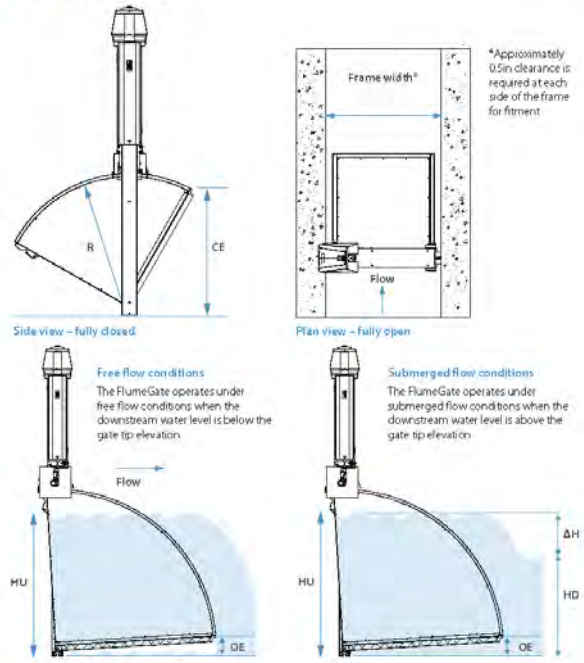

- Frame width** Width of the FlumeGate's external frame
- R** FlumeGate radius as specified in model number (i.e. FGB-xxxx-RADIUS)
- CE** Fully closed gate elevation (checking height)
- OE** Fully open gate elevation
- HU** Upstream water level
- HD** Downstream water level
- ΔH** Head loss across the gate (HU-HD)
- ΔH_{min}** Minimum head loss required to maintain flow measurement accuracy
- Freeboard** Distance between checking height and upstream water level (CE-HU)
- HU_{max}** Maximum upstream water level, specified equal to checking height (HU_{max} = CE)
- Q_F** Flow rate at free-flow conditions with gate fully open (HU = CE rounded down to nearest 3in, HD = 0)⁵
- Q_S** Flow rate at submerged flow conditions with gate fully open (HU = CE rounded down to nearest 3in, HD = HU - 3in)⁵
- Q_SΔH_{min}** Flow at minimum head loss conditions with gate fully open (HU = CE rounded down to the nearest 3in, HD = HU - ΔH_{min})⁵

⁵ Common practice is to design the FlumeGate with freeboard, consistent with district design policies. Refer to Rubicon's flow rating tables for the gate flow capacity across the range of upstream and downstream water levels. Please consult a Rubicon sales engineer for flow rating tables and additional sizing and selection support.

About Rubicon Water

Rubicon Water delivers advanced technology that optimizes gravity-fed irrigation, providing unprecedented levels of operational efficiency and control, increasing water availability and improving farmers' lives. Founded in 1995, Rubicon has more than 35,000 gates and meters installed in TCC systems in 17 countries.

DS-FG-03/22-075

SCADAConnect™ Live



Remote Gate Monitoring and Control

SCADAConnect Live is the cloud-based version of Rubicon's SCADAConnect remote monitoring and control solution. It's ideal for users migrating from manually-managed operations to remote monitoring and control. Low upfront costs, easy set-up and subscription billing means that this high-performance SCADA solution is cost-effective even for smaller irrigation districts.

Features

- 

Securely monitor and control your gates remotely
A truly mobile solution that doesn't tie you to a control room. Industry-standard security ensures your data and devices are secure. No need to physically visit a site to observe gate operation. You can adjust any of the control parameters for the gate-flow, level, position from any web-enabled device.
- 

Set water schedules and flows
SCADAConnect Live provides the capability of setting water schedules and flows straight from your web-enabled device.
- 

Graphing and trending tools
Convert each site's stored data into readily accessible information, enabling you to view historical performance at a glance.
- 

Scalable infrastructure
SCADAConnect Live can be integrated into a full-scale server-based SCADA system in the future should your SCADA needs grow.
- 

Remote troubleshooting
SCADAConnect Live introduces a feature for instant remote access by Rubicon Support for troubleshooting and assistance should the need arise.
- 

Easy data analysis
Data including flow rates, gate position, water levels and more can be easily downloaded to a .CSV file and imported into a spreadsheet program.
- 

"Plug and play"
SCADAConnect Live is easy to use and avoids the need for complicated integration. It works seamlessly with Rubicon's gate and meter products out-of-the-box and can also be configured to manage third party devices.
- 

Set alerts designed with irrigation districts in mind
Real-time performance monitoring and SMS (text) or email alerts let you know if there are any issues so you can take action before problems occur. Should a storm or other event arise, adjustments can be made from afar – no need to go to the site to make adjustments.



What can SCADAConnect Live do for your district?

- Remote **monitoring** of gates and meters
- Remote **control** of gates and meters
- SCADA **automation** at a low entry cost
- **Secure** operations, data capture, exporting and reporting



“ SCADAConnect Live is very beneficial to our District and canal riders. It enables us to remotely operate our canal system, which is very crucial in extreme weather events. It also helps us save money on fuel and wear and tear on our vehicles. ”

Troy Allen, Delta Lake Irrigation District – Edcouch, TX

Data Sheet

inquiry@rubiconwater.com | www.rubiconwater.com

© 2020 Rubicon Water, Inc. | California Contractors License Number 984209

Budget Narrative

Salaries and Wages & Fringe Benefits

The certified current rates of pay for the project manager, operations lead, and crew are the rates listed in the budget proposal. These salaries are applied consistently to all federal and non-federal activities of FID. The fringe benefits are the district's portion of employee benefits costs.

Travel, Equipment, Materials & Supplies, Other Expenses & Indirect Costs

There is no travel authorized for this project nor included in the budget proposal. All equipment to be used on this project is owned by FID or will be purchased by FID. Therefore, the equipment budget is shown as an in-kind contribution by FID as if it were owned by FID. The rates in the budget proposal are in accordance with the USACE equipment rates for the region. The time estimate for each piece of equipment was determined from the average usage on similar past District projects. The materials and supplies listed in the budget proposal are all for construction efforts related to the gate site prep and installation. The costs for materials were estimated from budgetary quotes obtained from distributors and past District projects. The total listed as incidental is for unforeseen expenses that might arise, such as small electrical components, wire, freight, or tools that might break. The indirect cost represents Idaho state and local sales taxes and clerical staff time to prepare reports and track project expenses. The clerical staff hourly rate shown in the budget proposal includes the fringe benefits.

Environmental/Regulatory Compliance Costs, Contractual/Third-Party In-Kind Contributions

Environmental compliance has been completed. An invoice from this activity can be provided upon request. This project does not expect any other contractual expenses, and the district does not anticipate any contributions matching this description.

BUDGET ITEM DESCRIPTION	COMPUTATION		Quantity	TOTAL
	\$/Unit	Quantity	Type	COST
Salaries and Wages				
Project Manager	\$32.56	100	Hours	\$3,256.00
Operations Lead	\$19.50	55	Hours	\$1,072.50
Operator	\$17.92	55	Hours	\$985.60
Crew Member	\$17.00	55	Hours	\$935.00
Fringe Benefits				
Included in rates shown	Labor Costs	265		\$6,249.10
Contractual/ Construction				
Environmental Compliance	\$5,500.00	1	Invoice	\$5,500.00
FID Equipment				
318 Excavator	\$74.68	15	Hours	\$1,120.20
Mini Excavator	\$22.40	20	Hours	\$448.00
1-Ton Truck	\$53.40	40	Hours	\$2,136.00
½-Ton Truck	\$34.95	40	Hours	\$1,398.00
Truck Chassis & Dump Bed	\$72.89	15	Hours	\$1,093.35
Concrete Saw	\$3.19	15	Hours	\$47.85
Supplies and Materials				
Gate East Canal Headgates	\$41,444.00	2	Units	\$82,888.00
Walkways for Gates	\$1,966.00	2	Units	\$3,932.00
Gate Installation, Supervision, and Commissioning	\$2,350.00	2	Units	\$4,700.00
SCADA Service Agreement	\$1,500.00	1	Units	\$1,500.00
Other				
Incidentals			Incidental costs incurred throughout project	\$22,792.24
TOTAL DIRECT COSTS				\$140,53.84
Indirect Costs				
Shipping		\$10,000.00		\$10,000.00
Office Manager	\$23.85	10	Hours	\$238.50
TOTAL INDIRECT COSTS				\$10,238.50
TOTAL PROJECT COSTS				\$150,292.34