

HYDRAULIC MODEL STUDIES FOR THE PACHECO TUNNEL ENERGY DISSIPATOR



*Hydraulics Branch
Division of General Research
Engineering and Research Center
Bureau of Reclamation*

September 1976
GR-18-76

1. REPORT NO. GR-18-76	2. GOVERNMENT ACCESSION NO.	3. RECIPIENT'S CATALOG NO.	
4. TITLE AND SUBTITLE Hydraulic Model Studies for the Pacheco Tunnel Energy Dissipator		5. REPORT DATE September 1976	
		6. PERFORMING ORGANIZATION CODE	
7. AUTHOR(S) R. L. George		8. PERFORMING ORGANIZATION REPORT NO. GR-18-76	
9. PERFORMING ORGANIZATION NAME AND ADDRESS Bureau of Reclamation Engineering and Research Center Denver, Colorado 80225		10. WORK UNIT NO.	
		11. CONTRACT OR GRANT NO.	
12. SPONSORING AGENCY NAME AND ADDRESS		13. TYPE OF REPORT AND PERIOD COVERED	
		14. SPONSORING AGENCY CODE	
15. SUPPLEMENTARY NOTES			
<p>16. ABSTRACT</p> <p>Hydraulic model studies were conducted on a 1:11.54 scale model to assure satisfactory performance of the control structure for the Pacheco Tunnel, a segment of the San Felipe Division of the Central Valley project in West Central California. The initial design performed satisfactorily except for subatmospheric pressures downstream from the control gate and on the energy dissipator baffle piers. The subatmospheric pressures occurred only for heads above 220 feet (67.1 metres (m)) of water and gate openings between 3 and 8 percent. An elliptical section 6 inches (152 millimetres (mm)) wide was placed on both sidewalls downstream from the gate slope, which raised the pressures downstream from the gate. Also, the bypass was enlarged to a 20-inch (508-mm) pipe so that the gate would not be required to operate at gate openings less than 5 percent open. The potential cavitation pressures measured on the original round-top baffle pier were minimized by using a modified flattop baffle pier, which resulted in pressures only slightly below atmospheric.</p>			
<p>17. KEY WORDS AND DOCUMENT ANALYSIS</p> <p>a. DESCRIPTORS-- / hydraulic models/ *slide gates/ *baffle piers/ *stilling basins/ *energy dissipation/ hydraulic jump/ model studies/ cavitation/ subatmospheric pressure/ tunnel hydraulics/ design criteria/ flow control/ hydraulic structures/ discharge (water)</p> <p>b. IDENTIFIERS-- / subsurface energy dissipation structures/ Pacheco Tunnel, CA</p> <p>c. COSATI Field/Group 13M COWRR: 1313.1</p>			
18. DISTRIBUTION STATEMENT		19. SECURITY CLASS (THIS REPORT) UNCLASSIFIED	21. NO. OF PAGES 39
		20. SECURITY CLASS (THIS PAGE) UNCLASSIFIED	22. PRICE

GR-18-76

**HYDRAULIC MODEL STUDIES
FOR THE PACHECO TUNNEL
ENERGY DISSIPATOR**

by
R. L. George

**Hydraulics Branch
Division of General Research
Engineering and Research Center
Denver, Colorado
September 1976**

UNITED STATES DEPARTMENT OF THE INTERIOR * BUREAU OF RECLAMATION

ACKNOWLEDGMENT

The model studies described in this report were done in cooperation with the Tunnels and Pipelines Section of the Water Conveyance Branch, Division of Design. The studies were performed under the direction of T. J. Rhone, Head, Applied Hydraulics Section of the Hydraulics Branch, Division of General Research.

CONTENTS

	<u>Page</u>
Purpose	1
Results	1
Applications	2
Introduction	3
The model	5
The investigation	12
Preliminary gate studies	12
Capacity tests	12
Downstream pressures	17
Modified gate	23
Gate modification	23
Capacity tests	25
Downstream pressures	28
Stilling basin studies	29
Baffle piers	29
Wave suppressors	37
Basin height and length	37

FIGURES

<u>Figure</u>		<u>Page</u>
1	Location map	4
2	Original design of control structure	7
3	Model drawing	10
4	Control gate and baffle piers	11
5	Location of piezometers downstream from gate slot	13
6	Upstream head and head loss at gate as a function of discharge, before gate modification	14
7	Coefficient of discharge as a function of gate opening	18
8	Pressures downstream from gate slot	20
9	Strip chart recordings of pressures at piezometers 1 and 20; discharge 167 ft ³ /s (4.73 m ³ /s), upstream head 240 ft (73.2 m), gate opening 5 percent	21
10	Strip chart recordings of pressures at piezometers 1 and 20; discharge 262 ft ³ /s (7.42 m ³ /s), upstream head 239 ft (72.8m), gate opening 8 percent	22

FIGURES - Continued

<u>Figure</u>		<u>Page</u>
11	Modification to gate downstream from gate slot	24
12	Upstream head and head loss at the gate, after gate modification, as a function of discharge	26
13	Flow in basin for maximum discharge and maximum head	30
14	Location of piezometers on original baffle pier	31
15	Mean pressures on baffle piers as a function of distance from upstream face	32
16	Strip chart records for piezometers 5, 6, and 7; discharge 480 ft ³ /s (13.6 m ³ /s), upstream head 242.4 ft (73.9 m), gate opening 13.7 percent	33
17	Modified baffle pier showing location of piezometers	35

FIGURES - Continued

Figure

Page

18	Strip chart records for modified piers, piezometers 1, 2, and 3; discharge 480 ft ³ /s (13.6 m ³ /s), upstream head 242.4 ft (73.9 m), gate opening 13.7 percent	36
----	----------------------------------------------------------------------------------------------------------------------------------------------------------------------------------------------------------	----

TABLES

<u>Table</u>		<u>Page</u>
1	Upstream head, reservoir elevation, and gate openings for various discharges before the gate was modified	16
2	Upstream head, reservoir elevation, and gate openings for various discharges after the gate was modified	25

PURPOSE

The objective of the study was to aid in developing the design for the flow control gate and stilling basin of the Pacheco Tunnel.

RESULTS

1. Pressures well below scaled cavitation pressure were measured immediately downstream from the gate slot in the original design for gate openings between 3 and 8 percent. A modified section which gradually decreased the area downstream from the gate slot was tested. An elliptical section 6 inches (152 millimetres (mm)) wide was placed along both walls downstream from the gate, which raised pressures to a satisfactory range for all gate openings and heads.
2. The location of the baffle piers should not be changed from the original positions. A modified, flattop, baffle pier is recommended instead of the rounded top of the original design. The modified baffle pier will have higher pressures, i.e., less negative, along the top and will not be as susceptible to cavitation damage as the original baffle pier.
3. The roof of the stilling basin was usually well above the water surface. Consequently, the roof of the stilling basin can be lowered

at the upstream end by 5 feet (1.5 m) and tapered to the original height of 72 feet (21.9 m) from the upstream end of the basin.

4. The wave suppressor system effectively minimizes the surface waves in the tunnel except for some long period waves. The long period waves have small amplitudes and should not create any adverse effects in the downstream tunnel.

5. The 14-inch (356-mm) diameter bypass line required the gate to operate with very small gate openings, which caused subatmospheric pressure conditions. This bypass should be enlarged to a 20-inch (508-mm) line that will handle all flows up to $185 \text{ ft}^3/\text{s}$ ($5.2 \text{ m}^3/\text{s}$). Thus, the smallest required gate opening for maximum head will be 6 percent, which minimizes the potential subatmospheric pressures downstream from the gate slot.

APPLICATIONS

These tests were performed to verify and improve the design of the control gate and stilling basin for the Pacheco Tunnel. However, the results will be of interest to designers of high-pressure slide gates operating under submerged conditions and stilling basins of similar design.

INTRODUCTION

The Pacheco Tunnel will convey water from an intake structure in the western end of the San Luis Reservoir through an 11-foot (3.3-m) diameter circular tunnel under the Pacheco Pass, then to the distribution system of the Santa Clara Valley water users.

The San Luis Reservoir is located in west central California, figure 1, and has a total capacity of 2,040,500 acre-feet ($2.517 \times 10^9 \text{ m}^3$). A new point of withdrawal from the reservoir will be the Pacheco Tunnel which will be about 10.4 miles (16.7 kilometres (km)) long. The maximum discharge of the tunnel will be $480 \text{ ft}^3/\text{s}$ ($13.6 \text{ m}^3/\text{s}$) for all reservoir elevations from 330 to 544 feet (100.6 to 165.8 m). At a reservoir elevation of 326 feet (99.4 m), a discharge of $325 \text{ ft}^3/\text{s}$ ($9.2 \text{ m}^3/\text{s}$) is required and the minimum discharge is $40 \text{ ft}^3/\text{s}$ ($1.1 \text{ m}^3/\text{s}$) for all reservoir levels. A 20-inch (508-mm) diameter bypass line will have a capacity of $185 \text{ ft}^3/\text{s}$ ($5.2 \text{ m}^3/\text{s}$) at the maximum reservoir elevation. The bypass will be used to convey flows less than $185 \text{ ft}^3/\text{s}$ around the slide gate.

At high reservoir elevations above 326 feet (99.4 m), up to 210 feet (64.0 m) of excess head will exist in the tunnel. Consequently, a control structure was necessary to dissipate the excess head. The control structure consists of a 5- by 7-foot (1.52- by 2.13-m) slide

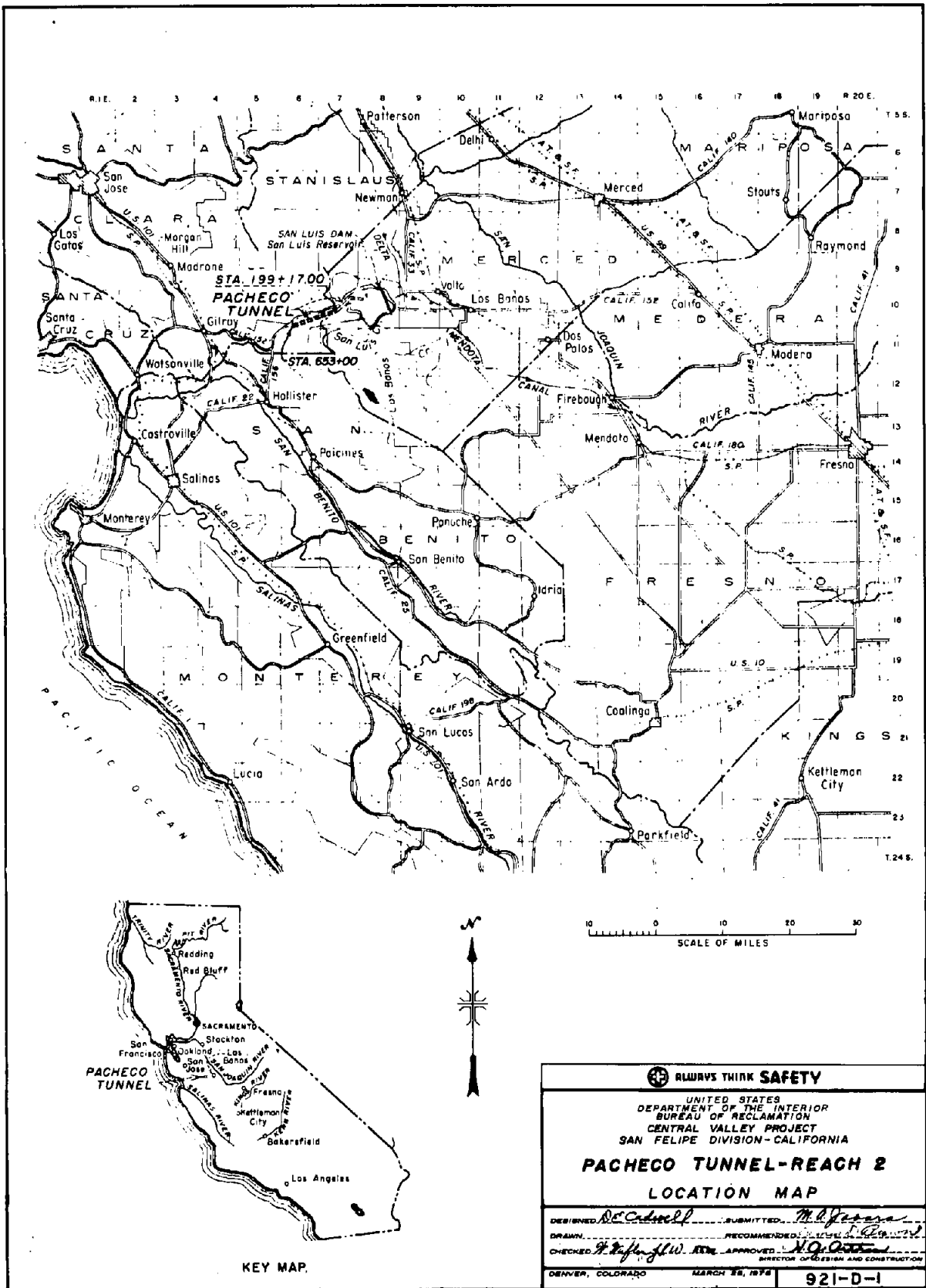

Figure 1. - Location map of Pacheco Tunnel.

gate, a stilling basin with baffle piers, and a wave suppressor system. This structure will be located about 200 feet (61 m) underground about 1.8 miles (2.9 kilometres (km)) from the tunnel intake. The width of the stilling basin ranges from 5 feet (1.5 m) at the upstream end to 11 feet (3.4 m) at the downstream end and is about 29 feet (8.8 m) high at its highest point downstream from the gate. The original design, figure 2, shows the relative position of the slide gate and the stilling basin. The tunnel downstream from the control structure was designed for free flow.

A hydraulic model was built to determine: (a) the operating characteristics of the gate, (b) the pressures on the baffle piers, and (c) the effectiveness of the control structure for heads and discharges within the operating range.

THE MODEL

The studies described in this report were performed on a 1:11.54 scale model of the control structure which included the slide gate, the stilling basin, and a section of the downstream tunnel including the 20-foot (6.1-m) diameter access shaft, figures 3 and 4.

The slide gate chamber was represented by a clear plastic section 5.20 inches (132 mm) wide by 7.28 inches (185 mm) high and 16.64 inches

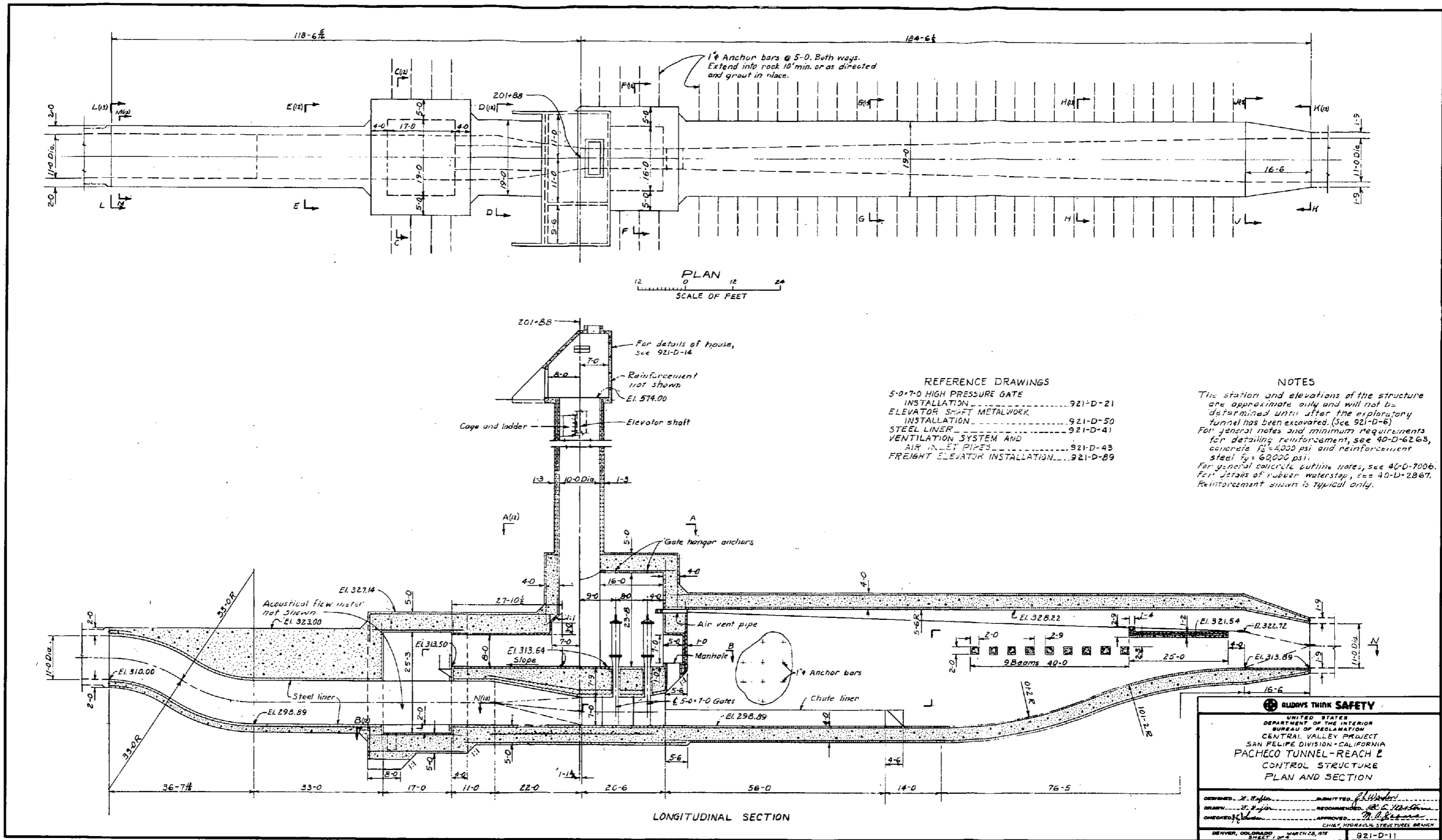

Figure 2. - Original design of control structure.

(423 mm) long. The stilling basin was a wood framework that diverged in width from 5.20 inches (132 mm) to 11.44 inches (291 mm) at the downstream end. One wall of the stilling basin was clear plastic; the bottom and the opposite wall were wood. A transition section connected the rectangular cross section of the gate section to the 12-inch (305-mm) diameter laboratory supply line. The pressures in the supply line were adjusted to simulate the total energy available at that point in the model.

Discharge quantities were measured with the Venturi meters in the permanent laboratory water supply. Pressures at various points in the model were measured by piezometers connected to either open tube water or mercury manometers. Also a plus or minus 2.5-lb/in² (17.2-kPa) strain gage pressure transducer was used to measure the fluctuating pressures at critical points in the model.

The model was designed and all test results were analyzed on a Froude model relationship.

Maximum model discharge was 1.061 ft³/s (0.030 m³/s) and the maximum model pressure at the gate was equivalent to 21 feet of water (6.4 metres-head). The model heads were obtained from the prototype heads adjusted for losses from the reservoir to the gate and then scaled according to the model scale. The datum used for all model piezometric heads was the elevation of the gate seat.

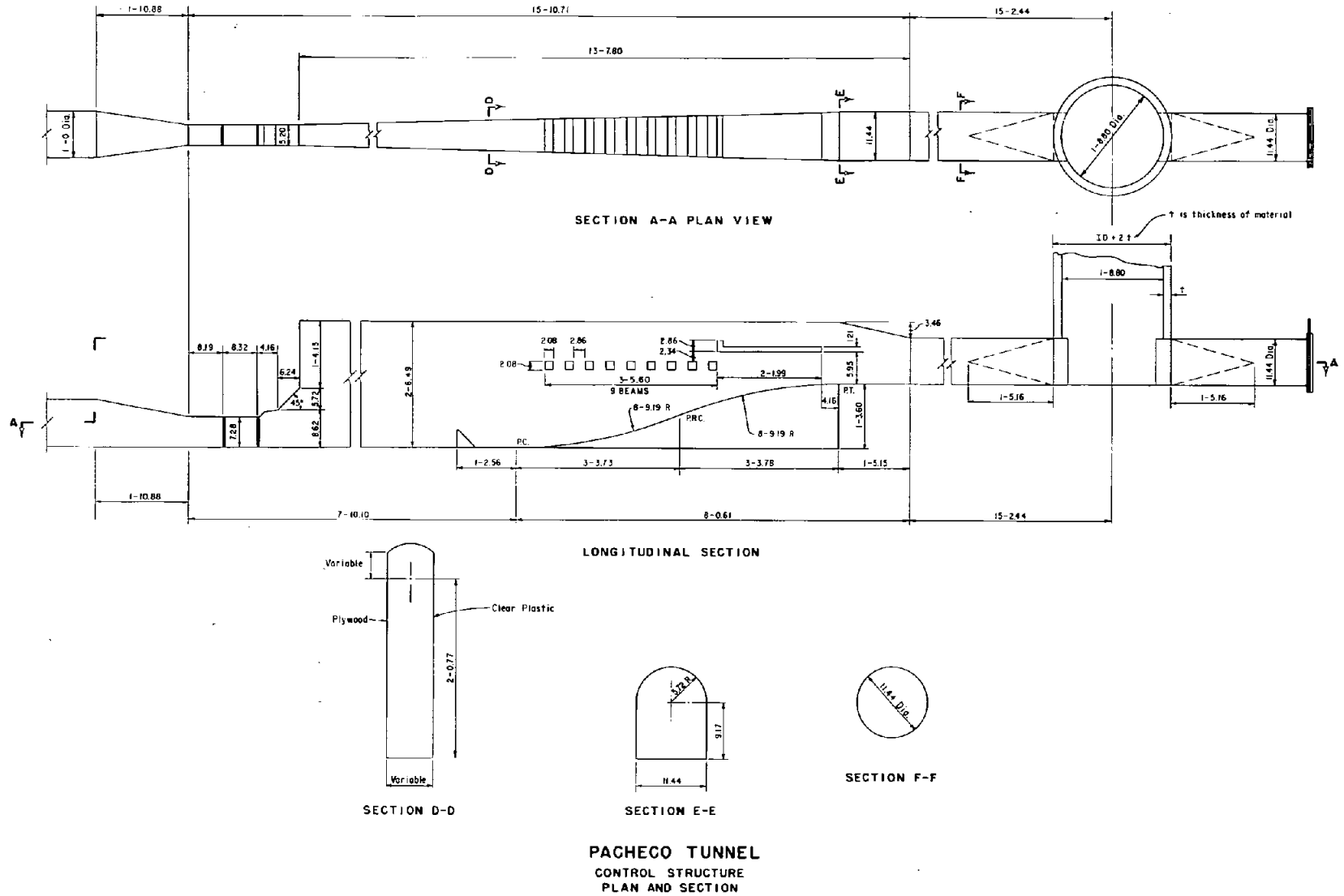
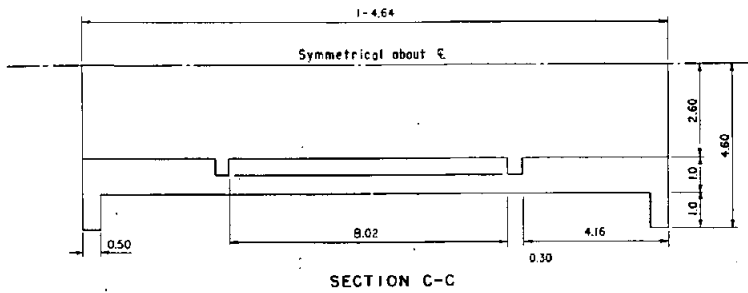
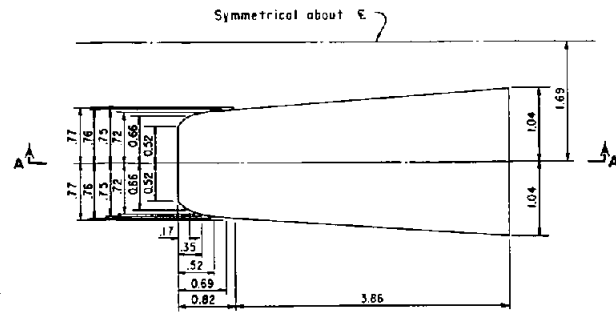

Figure 3. - Model drawing.



SECTION C-C



PLAN VIEW OF FLOOR BLOCKS

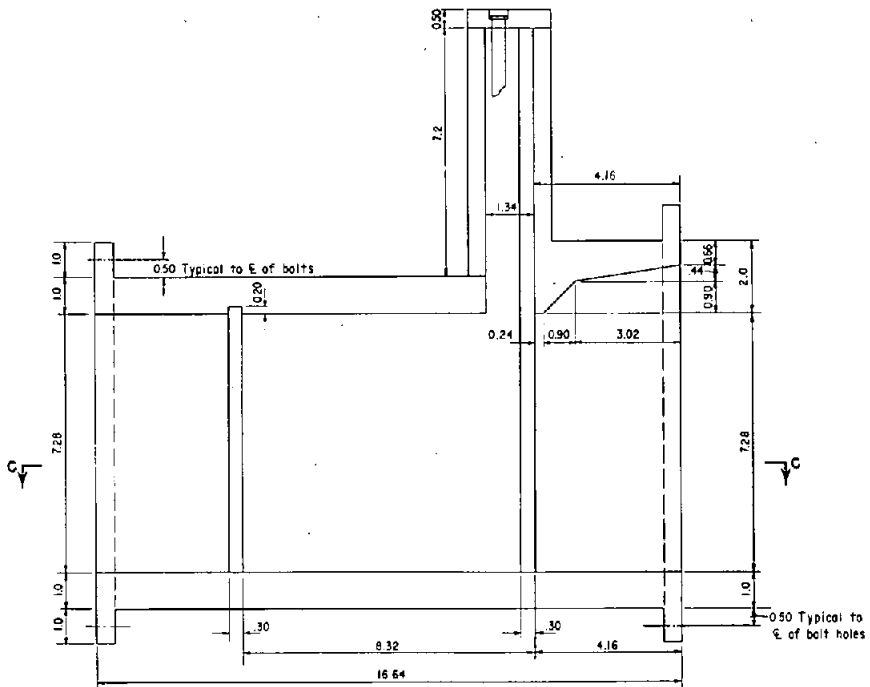

CONTROL GATE ELEVATION

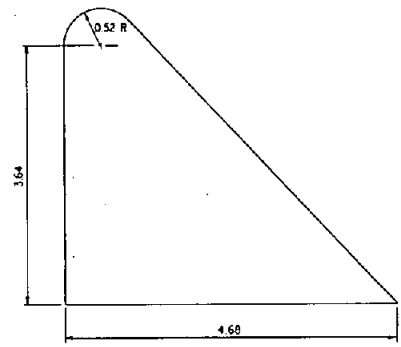

SECTION A-A

PACHECO TUNNEL

Figure 4. - Control gate and baffle piers.

THE INVESTIGATION

Preliminary Gate Studies

Capacity tests. - The discharge-head relationship of the gate was evaluated by measuring the heads upstream from the gate and at piezometer 19, figure 5a. The location of the piezometers on the structure after the downstream gate section was modified is shown in figure 5b.

The discharge-head curves for various gate openings are shown in figure 6 before the gate was modified. The tailwater in the model was adjusted to the theoretical normal depth in the downstream tunnel for each discharge. The dashed line indicates the upstream head as a function of discharge, while the solid line indicates head loss across the gate as a function of discharge. A discharge of 320 ft³/s (9.06 m³/s) was measured for 10 percent gate opening and maximum upstream head of 242.36 feet (73.87 m). The maximum head of 242.36 feet discharged 480 ft³/s (13.59 m³/s) through the gate when the gate was about 14 percent open. At 65 percent gate opening, about 325 ft³/s (9.20 m³/s) were discharged at the upstream head of 25.4 feet (7.74 m) which corresponds to a reservoir elevation of 326 feet (99.4 m). Several conditions of discharge, upstream head, and gate opening are shown in table 1. The

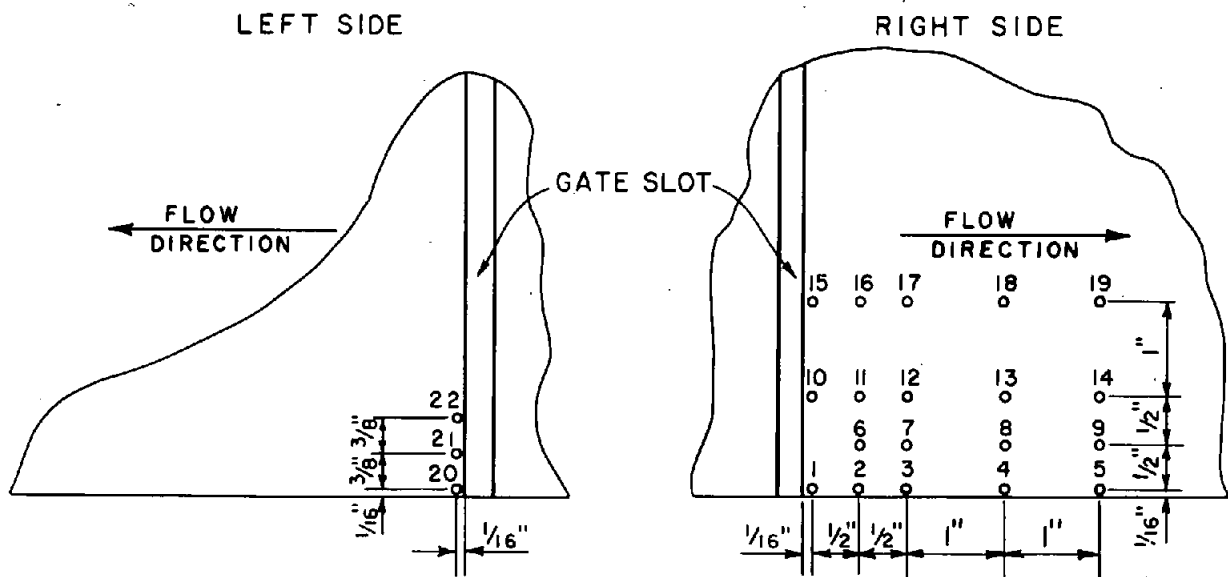

5-a Before modification

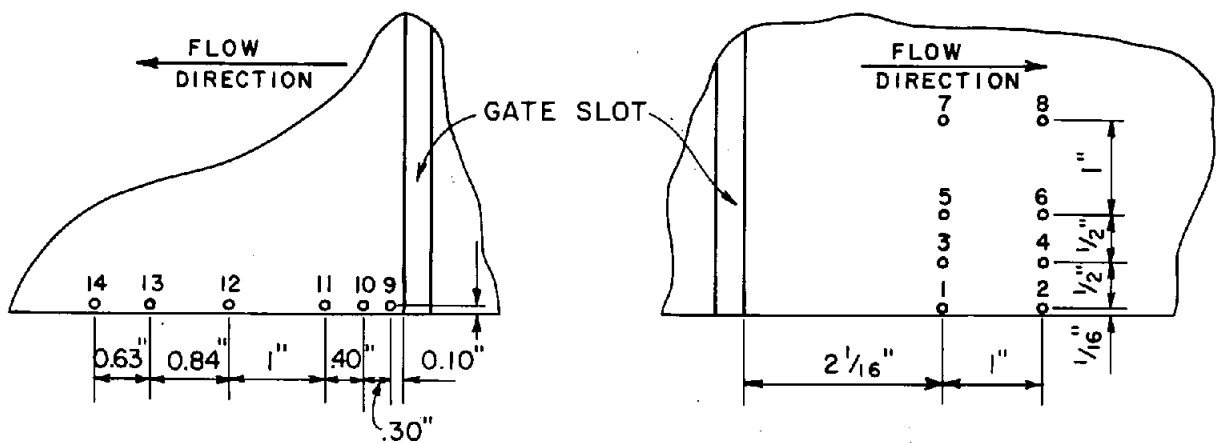

5-b After modification

Figure 5. - Location of piezometers downstream from gate slot.

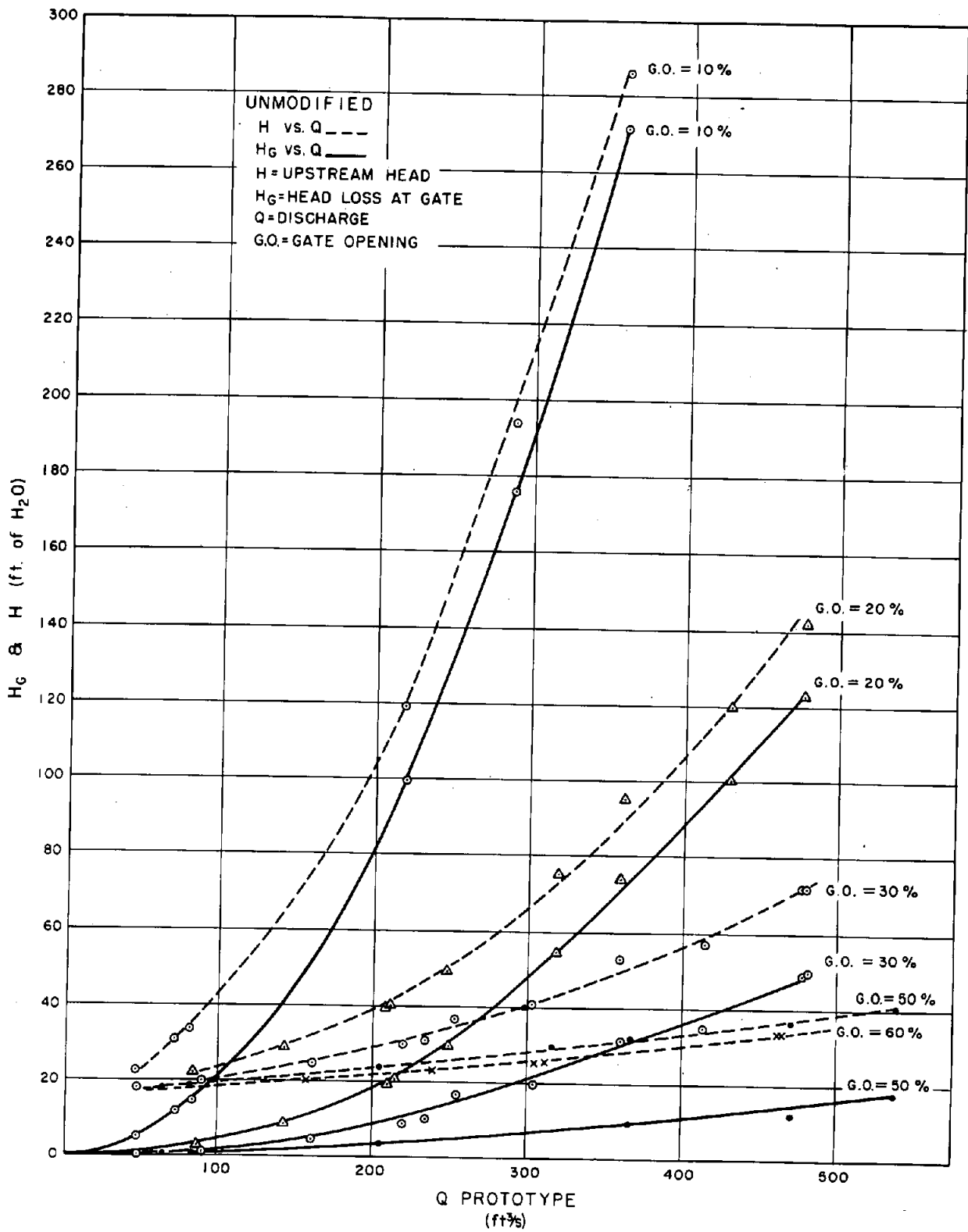

Figure 6. - Upstream head and head loss at gate as a function of discharge, before modification (sheet 1 of 2).

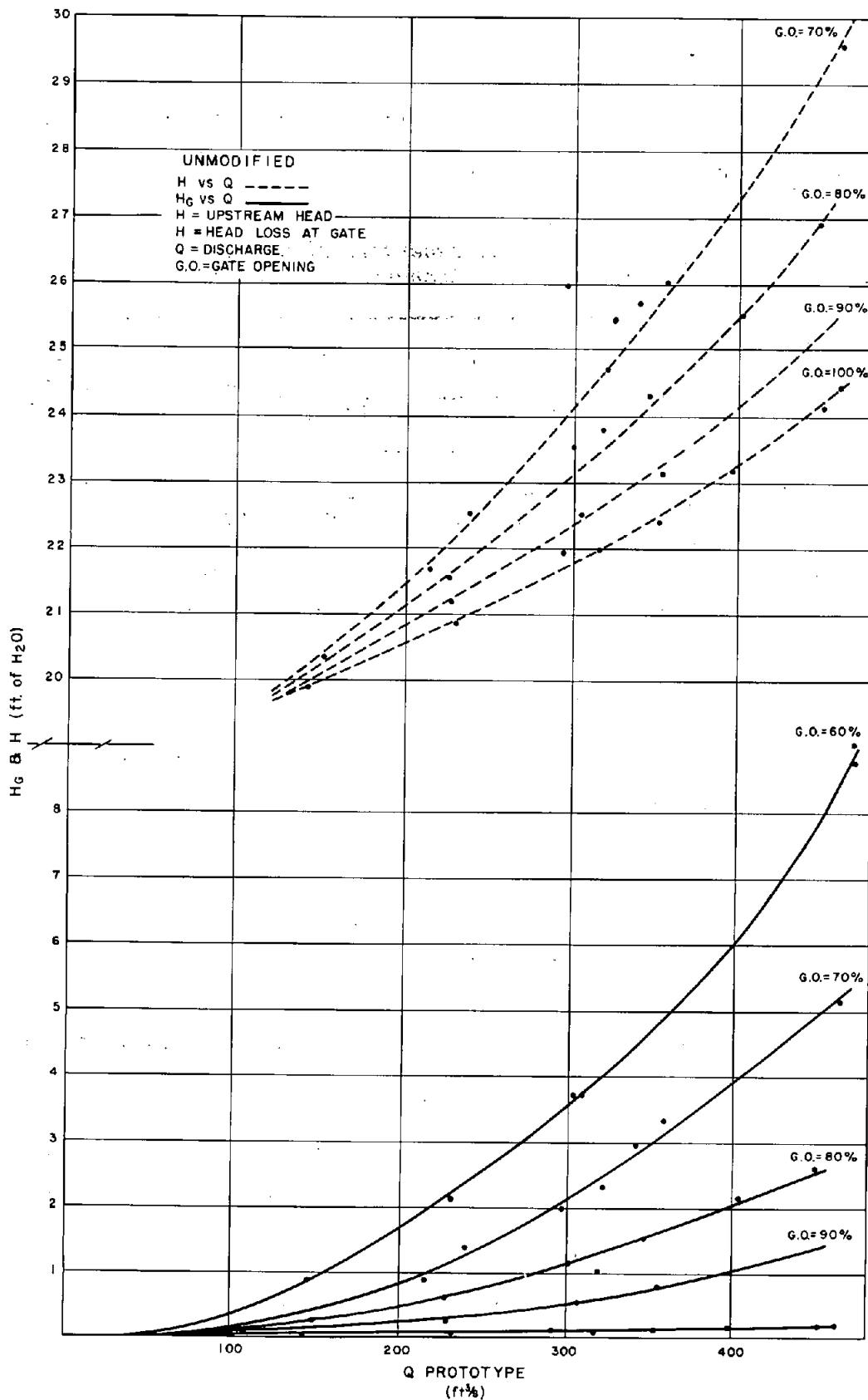

Figure 6. - Upstream head and head loss at gate as a function of discharge, before modification (sheet 2 of 2).

values in table 1 are from specific tests and may vary from the averaged curves shown in figure 6.

Table 1. - *Upstream head, reservoir elevation, and gate openings for various discharges - original gate*

Discharge		Upstream head		Reservoir elevation		Gate opening
(ft ³ /s)	(m ³ /s)	(feet)	(m)	(feet)	(m)	(percent)
480	13.59	242.36	73.87	544	165.8	14
480	13.59	28.36	8.64	330	100.6	75
480	13.59	24.12	7.35	324.7	99.0	100
325	9.20	25.4	7.74	326	99.4	65

The data for the head-discharge curves were used with the relationship below to compute a coefficient of discharge, C_d , for each gate opening:

$$C_d = \frac{Q}{\sqrt{2gH_g} \times A \times \text{G.O.}}$$

where, G.O. = the gate opening expressed as a decimal fraction of fully open gate height

A = area of the gate fully open (ft²)

H_g = head difference across the gate (ft)

Q = discharge (ft³/s)

g = acceleration of gravity (ft/s²)

An average value of C_d was computed from the data on the original design for each gate opening and is shown in figure 7. As the gate opening increased above 60 percent, the gate did not act as a control section and losses through the section were more similar to frictional losses in a conduit than losses through a gate. Consequently, values of C_d were not meaningful for gate openings greater than 60 percent.

Discharges less than 80 ft³/s (2.27 m³/s) were to be taken through the bypass rather than through the slide gate. The initial bypass was a 14-inch (356-mm) pipe, which had a maximum capacity of 80 ft³/s at reservoir elevation 544 feet (165.8 m). The slide gate had to be less than 5 percent open to throttle down to 80 ft³/s. Subatmospheric pressures developed downstream from the gate slot at the small gate openings. To avoid using the slide gate at smaller openings, the bypass was enlarged to a 20-inch (508-mm) diameter pipe. The larger pipe has a capacity of 185 ft³/s (5.24 m³/s) at maximum head. Therefore, the bypass will be used for discharges less than 185 ft³/s and the slide gate will not be required to operate at gate openings which cause subatmospheric pressures.

Downstream pressures. - Low subatmospheric pressures were measured downstream from the gate for conditions of maximum head at gate openings between 3 and 8 percent. For all gate openings greater

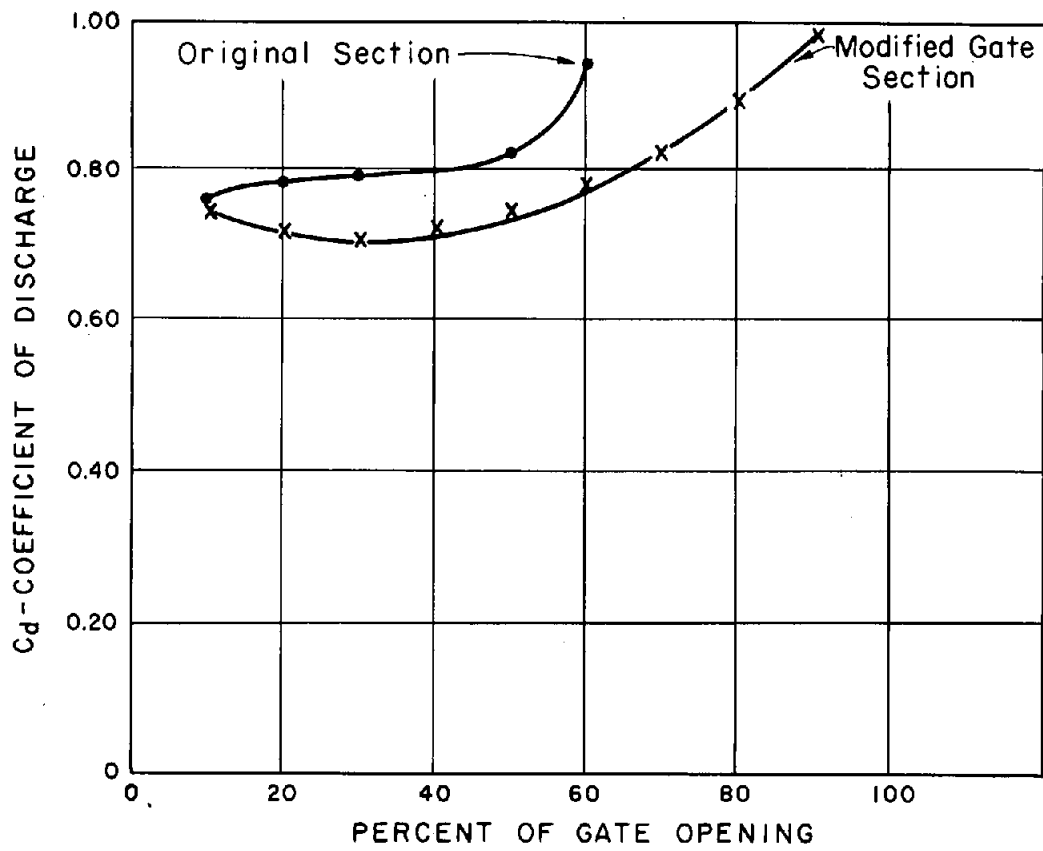

Figure 7. - Coefficient of discharge as a function of gate opening.

than 10 percent the piezometers indicated above atmospheric pressures. Figure 8 shows the pressures downstream from the gate as a function of distance from the gate slot for the smaller gate openings. Only piezometer 1 reached subatmospheric pressure. A pressure equivalent to 31.75 feet (9.67 m) of water below atmospheric was created by a discharge of $143 \text{ ft}^3/\text{s}$ ($7.59 \text{ m}^3/\text{s}$) and a gate opening of 8 percent. Additional piezometers were placed in the left side of the gate section to determine whether subatmospheric pressures were occurring above the floor immediately downstream from the gate slot, figure 5a. The additional piezometer taps were located on the model $1/16$ inch (1.6 mm) downstream from the gate slot on the left side of the gate section at heights of $1/16$ inch (1.6 mm), $7/16$ inch (11.1 mm), and $13/16$ inch (20.6 mm) above the floor. Observations for the maximum head and gate openings of 5 and 8 percent indicated subatmospheric pressures occurred only at piezometers 1 and 20, located $1/16$ inch downstream from the gate slot and $1/16$ inch above the floor. Dynamic pressures at piezometers 1 and 20 were measured with a pressure transducer and figures 9 and 10 are strip chart output from the observations. On both charts, a 4-mm deflection represents 11.54 feet (3.52 m) of water in the prototype. The flow conditions for the observations shown in figure 9 were near maximum head, discharge of $166.5 \text{ ft}^3/\text{s}$ ($4.71 \text{ m}^3/\text{s}$), and 5 percent gate opening. Subatmospheric pressures equivalent to 39.2 feet (11.95 m) of water and

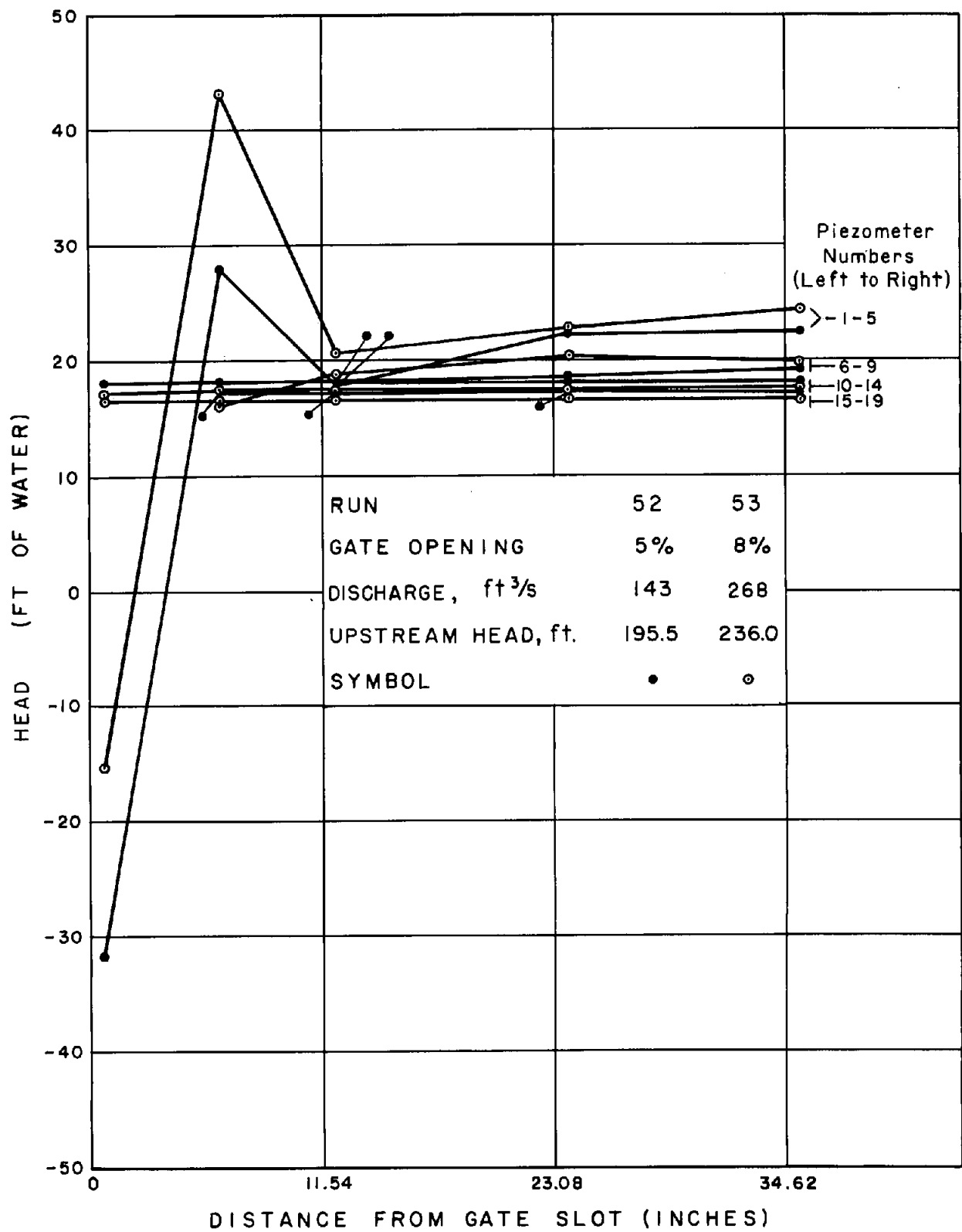

Figure 8. - Pressures downstream from the gate slot.

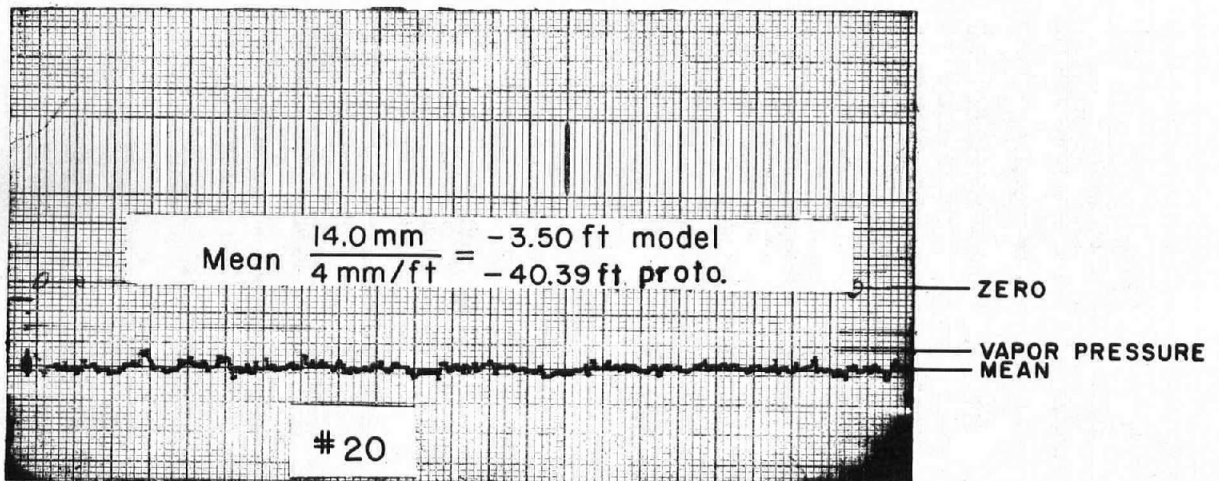
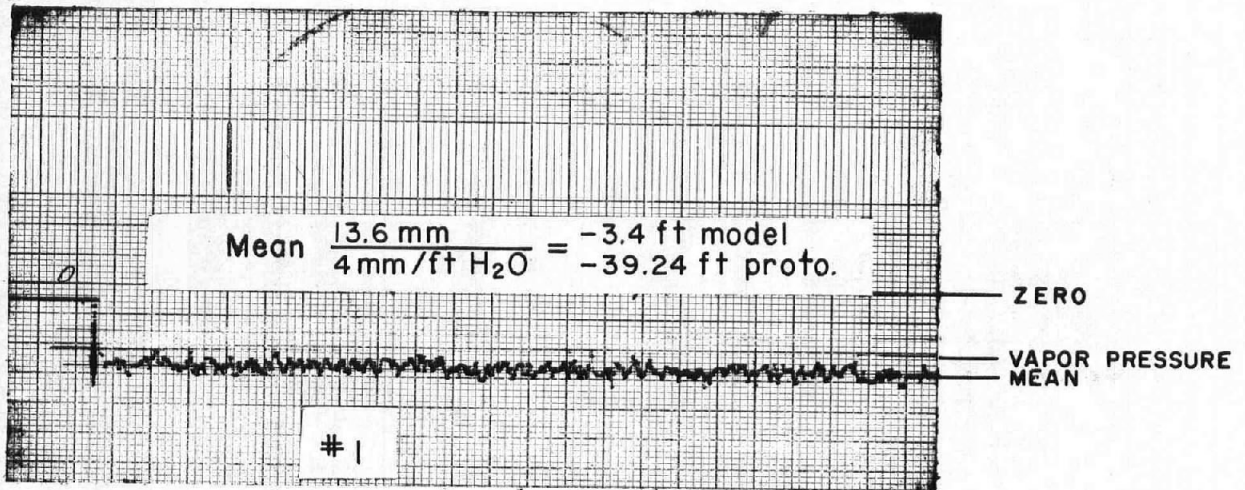

Figure 9. - Strip chart recordings of pressures at piezometers 1 and 20; discharge 167 ft³/s (4.73 m³/s), upstream head 240 ft (73.2 m), gate opening 5 percent.

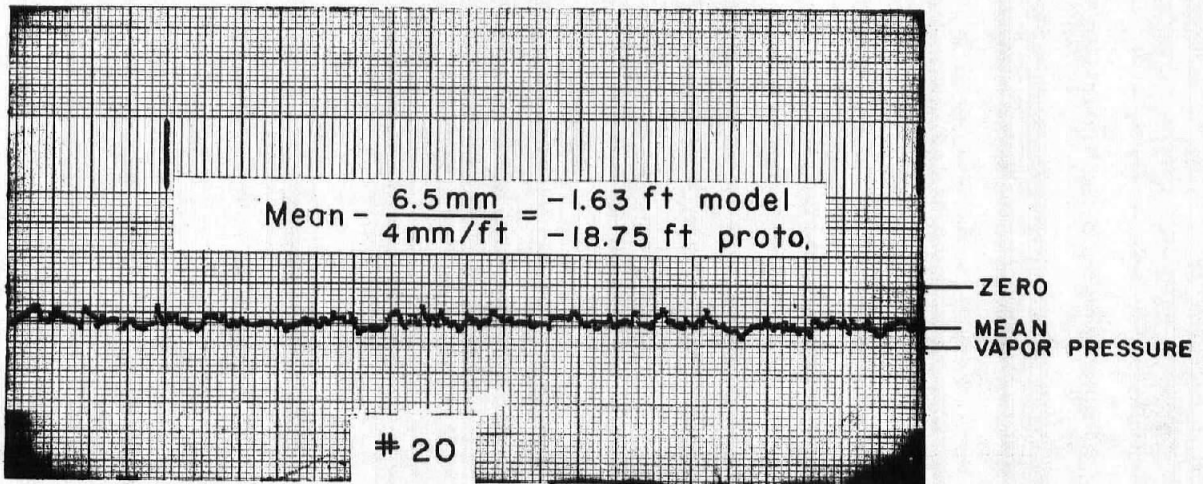
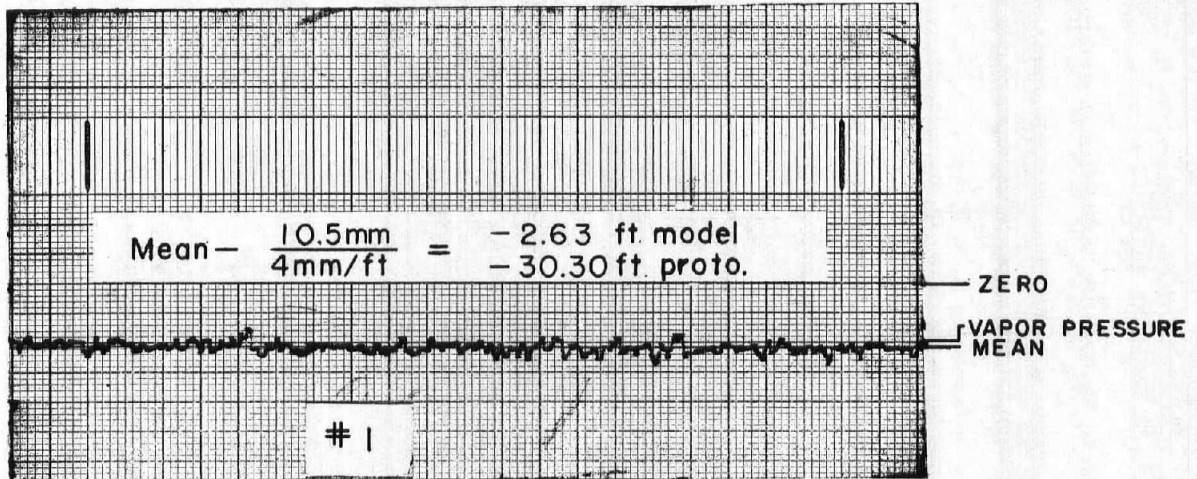

Figure 10. - Strip chart recordings of pressures at piezometers 1 and 20; discharge $262 \text{ ft}^3/\text{s}$ ($7.42 \text{ m}^3/\text{s}$), upstream head 239 ft (72.8 m), gate opening 8 percent.

40.4 feet (12.31 m) of water in the prototype were measured for the right side (number 1) and left side (number 20) piezometers, respectively. An unbalanced pressure in the model occurred for 8 percent gate opening with near maximum head and discharge of 262.4 ft³/s (7.43 m³/s). The strip chart trace of these pressures is figure 10. The pressure on the left side was equivalent to 18.8 feet (5.73 m) of water below atmospheric and the right side was equivalent to 30.3 feet (9.24 m) of water below atmospheric. This condition was not expected and could not be explained by uneven flow in the gate section.

Modified Gate

Gate modification. - The gate was modified to increase the pressures downstream from the gate slot. An elliptical section was placed downstream from the gate slot on both sides, as shown on figure 11, to minimize the subatmospheric pressures that began in the original design for gate openings less than 10 percent of the 7-foot (2.13-m) height. The upstream point of tangency of the ellipse is at the downstream edge of the gate slot and the downstream point of tangency is parallel to the wall, 6 inches (152 mm) inside the original designed surface and 2.5 feet (0.76 m) downstream from the gate slot. The ratio of the major axis to the minor axis of the ellipse is 5 to 1. A 6-inch (152-mm) wide filler section was also inserted downstream from the ellipse

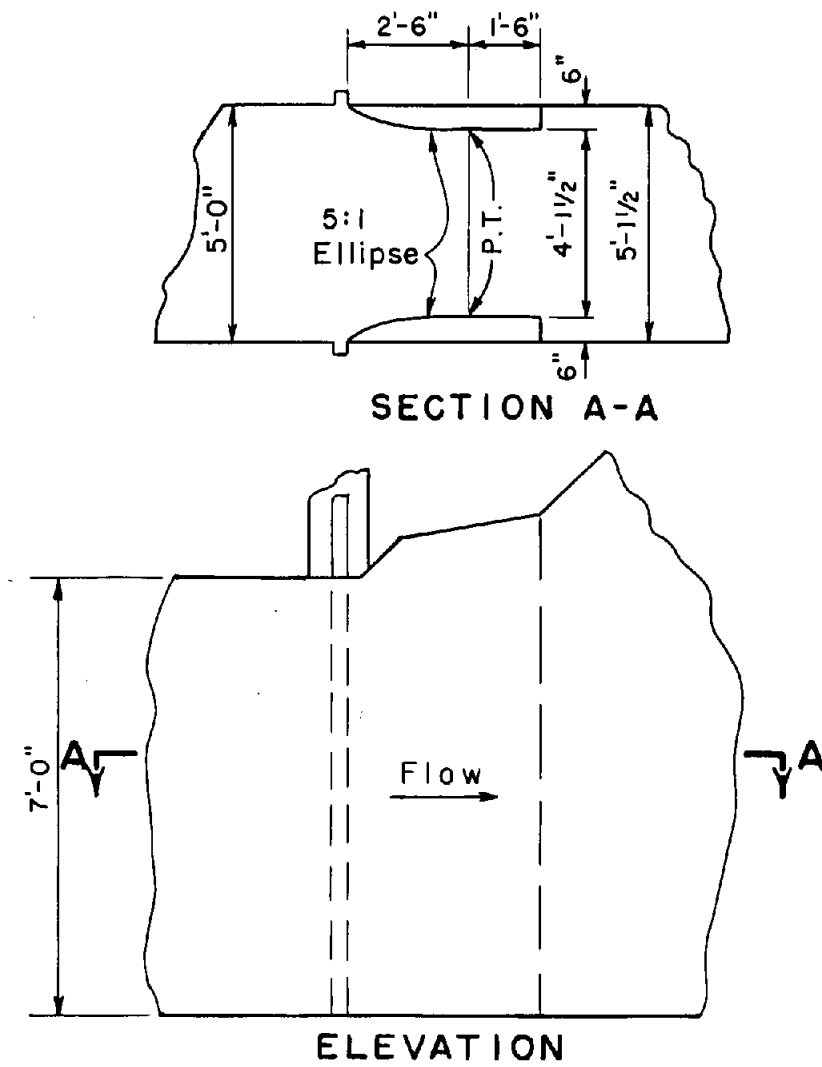

Figure 11. - Modification to gate downstream from gate slot.

which extended to the end of the gate chamber. This was requested by the designers to simplify the casting of the downstream portion of the gate.

Pressure losses across the modified gate were taken at the same upstream location as in the unmodified gate and at piezometer 7, see figure 5b, downstream from the gate.

Capacity tests. - The relationships between discharge and head for the modified gate are shown in figure 12. Table 2 summarizes several points of interest from these curves. The data shown in table 2 are from specific tests and may vary slightly from the averaged curves in figure 12.

Table 2. - *Upstream head, reservoir elevation, and gate openings for various discharges after the gate was modified.*

Discharge		Upstream head		Reservoir elevation		Gate opening (percent)
(ft ³ /s)	(m ³ /s)	(feet)	(m)	(feet)	(m)	
480	13.59	242.36	73.87	544	165.8	15.5
480	13.59	28.36	8.64	330	100.6	85.0
325	9.20	25.41	7.74	326	99.4	76.6
185	5.24	242.36	73.87	544	165.8	6.0

The modified gate created higher head losses than the unmodified section for all conditions and provided better flow control at large gate openings. This is demonstrated on figure 7 for the

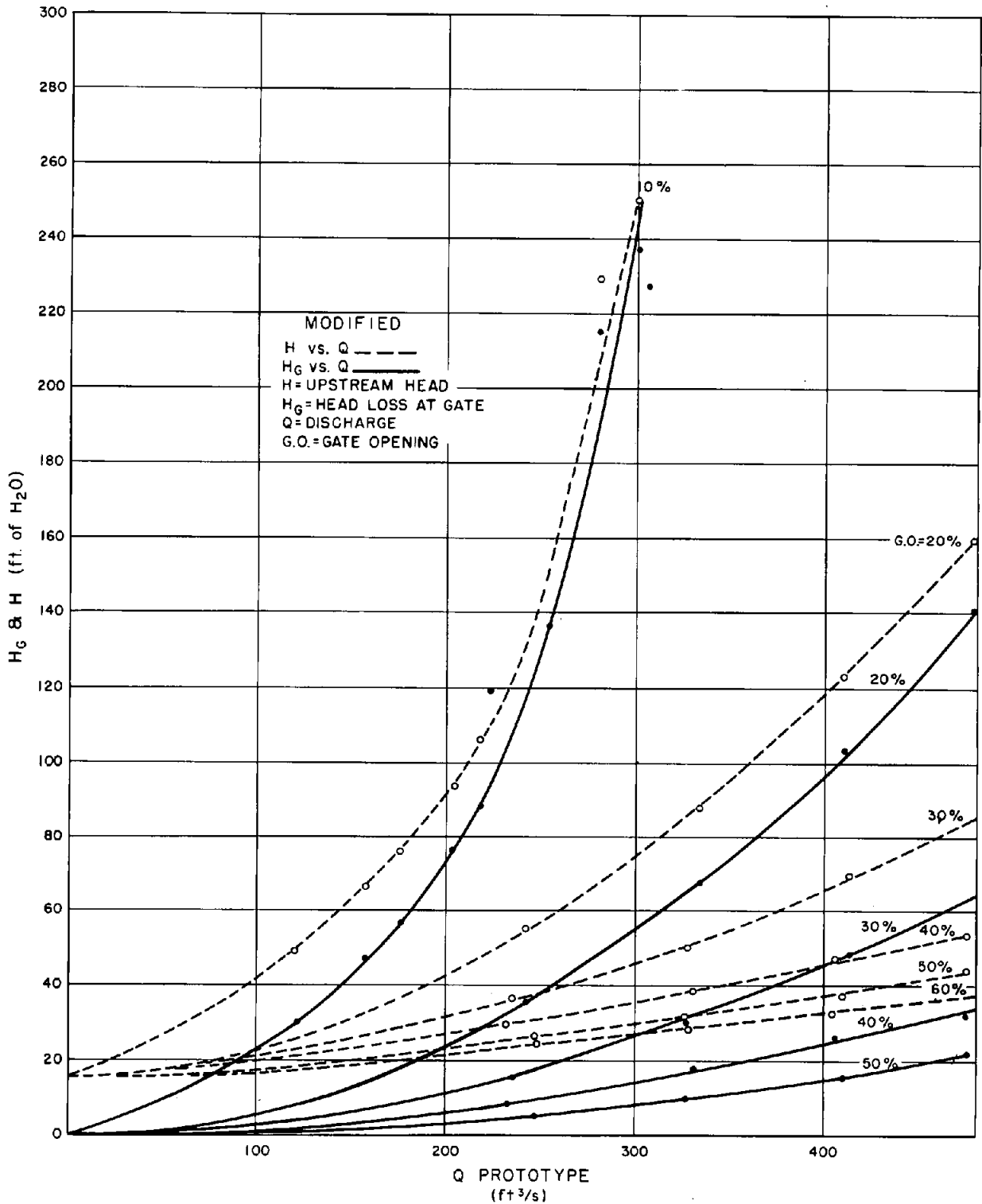

Figure 12. - Upstream head and head loss at the gate, after gate modification, as a function of discharge (sheet 1 of 2).

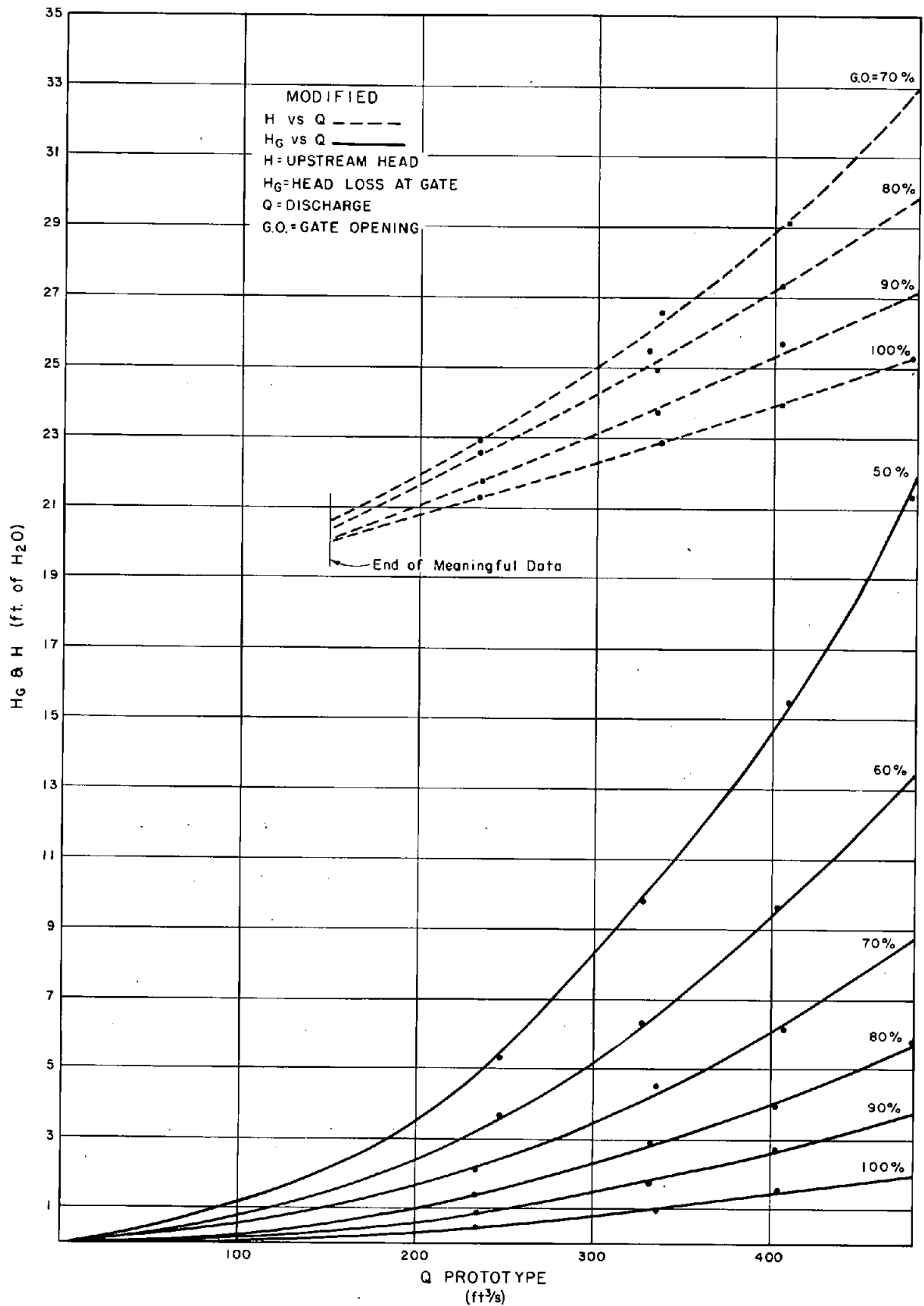

Figure 12. - Upstream head and head loss at the gate, after gate modification, as a function of discharge (sheet 2 of 2).

modified gate where the values of C_d are valid for gate openings through 90 percent instead of being limited to 60 percent.

Downstream pressures. - Pressure measurements were obtained on the configuration of piezometers shown in figure 5b after the elliptical and straight sections were installed. No subatmospheric pressures were observed for any gate opening 8 percent or less. However, for a gate opening of 10 percent, a discharge of 306.8 ft³/s (8.69 m³/s), and an upstream head of 242.6 feet (73.9 m), a subatmospheric pressure of 6.32 feet (1.93 m) of water was measured at piezometer 12. Also, at 15.5 percent gate opening, a discharge of 480 ft³/s (13.59 m³/s) and an upstream head of 240.6 feet (73.3 m), subatmospheric pressures of 2.76 feet (0.84 m), 1.09 feet (0.33 m), and 7.33 feet (2.23 m) of water were measured at piezometers 1, 3, and 12, respectively. These pressures were well above vapor pressure and should not cause any problems. The latter condition was the "worst case" condition observed for subatmospheric pressures on the modified gate. At any gate opening greater than 15.5 percent, maximum discharge was attained at lower upstream heads and no subatmospheric pressures occurred downstream from the gate. No pressure measurements were obtained with the pressure transducer because the mean pressures measured by the water manometer were well above vapor pressure.

The modified gate did not decrease the effectiveness of the stilling basin and did not have pressures low enough to be considered a problem. Thus, this modified section is recommended instead of the original straight section downstream from the gate slot.

Stilling Basin Studies

Baffle piers. - A significant amount of the energy dissipation in the stilling basin occurs by impact on the baffle piers and by turbulent flow around them. This turbulent flow can be seen in figure 13. The high velocity flow around the baffle piers may cause subatmospheric pressures to develop.

Figure 14 indicates locations of piezometer taps on the baffle piers. Pressures were measured either with open tube waterfilled manometers or by the plus or minus 2.5 lb/in² (17.2 kPa) pressure transducer. The pressures on the baffle piers for maximum discharge and maximum head conditions were measured and the mean values are plotted in figure 15 as a function of the distance from the upstream face of the pier. The lowest pressures were along the top of the pier for piezometers 5, 6, and 7, see figure 16. The fluctuating pressures shown on these strip chart records are at or below vapor pressure from 30 to 40 percent of the time. During the time the pressure is below vapor pressure,

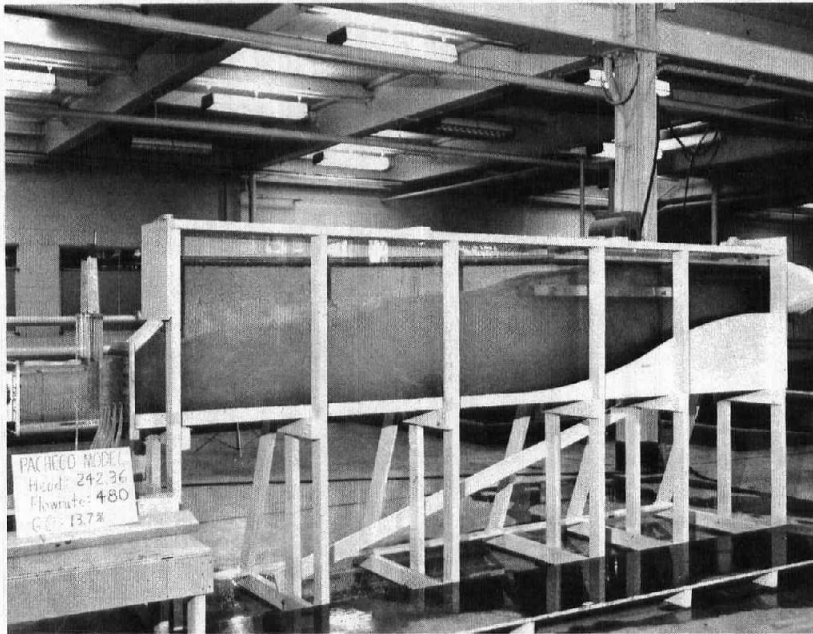

Figure 13. - Flow in basin for maximum discharge and maximum head, preliminary design. Photo P801-D-77278

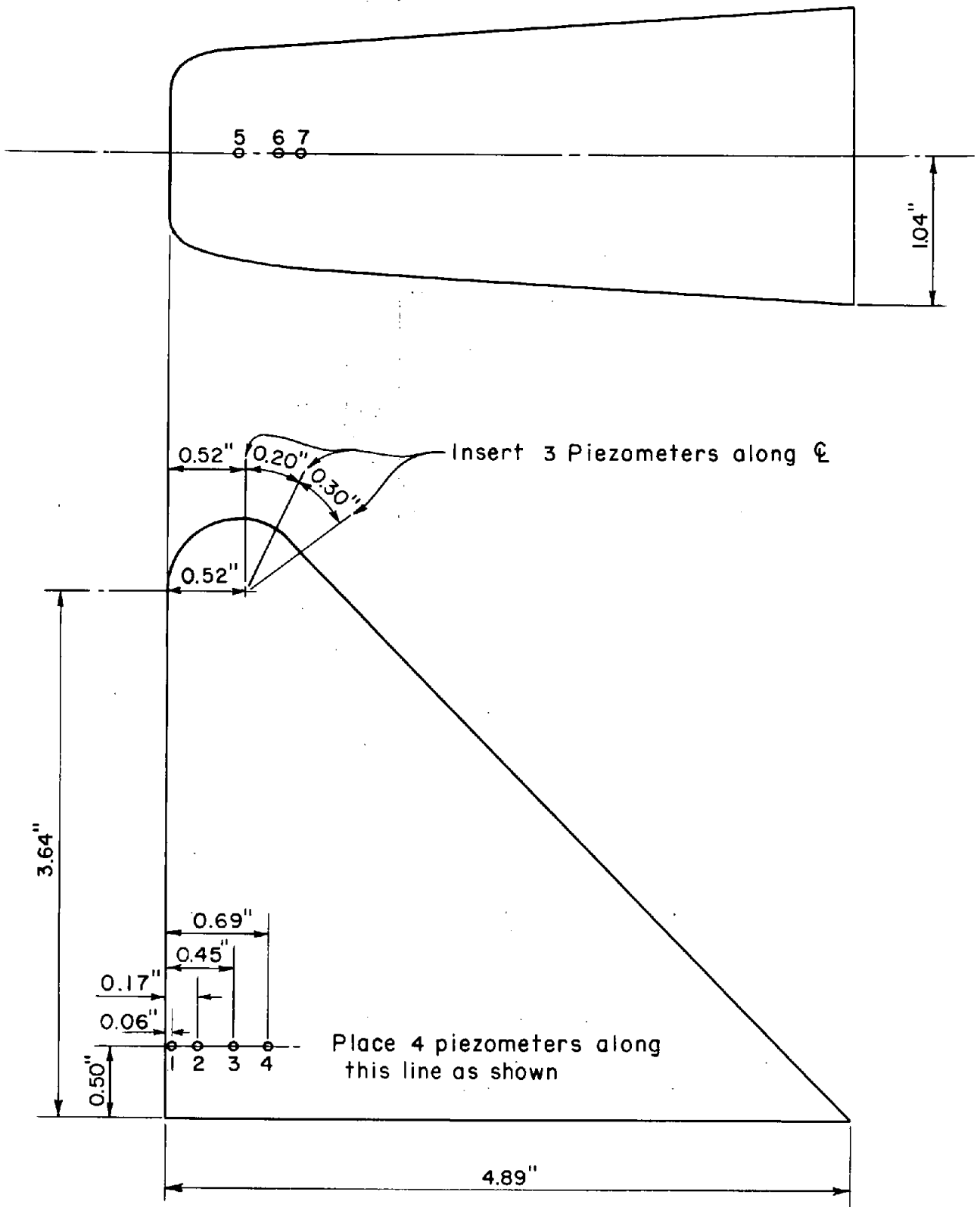

Figure 14. - Location of piezometers on original baffle pier.

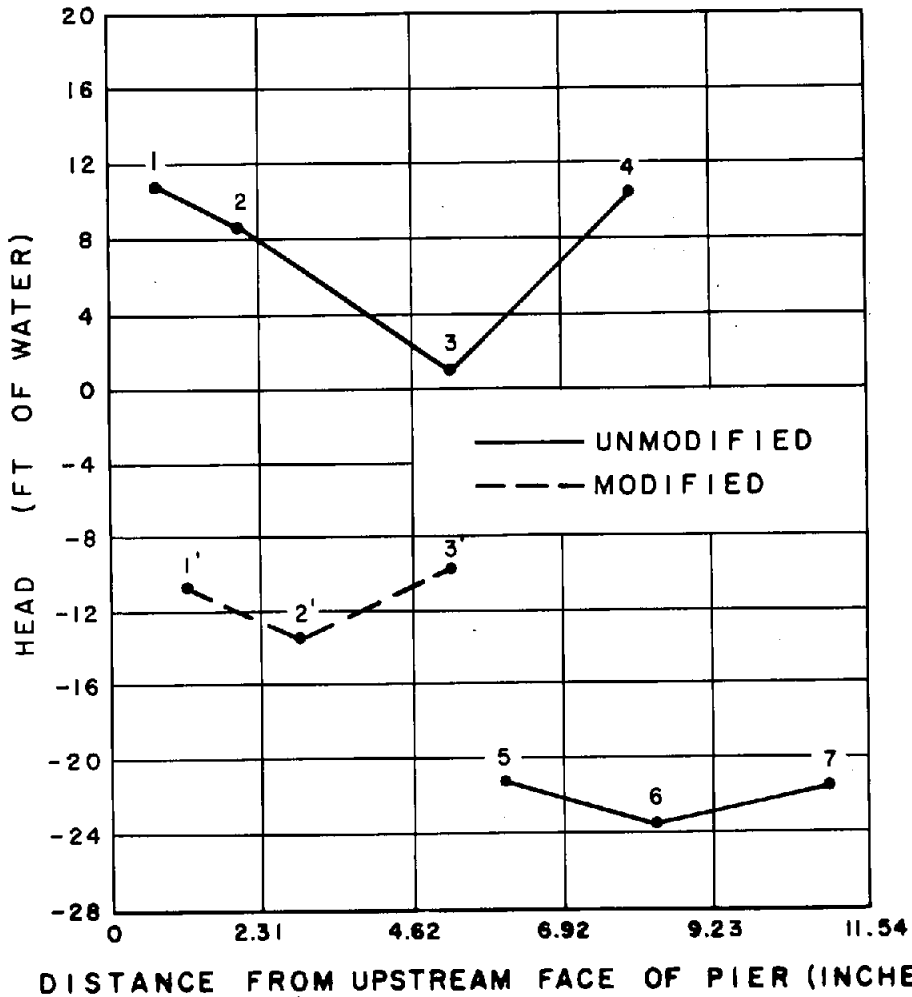

Figure 15. - Mean pressures on baffle piers as a function of distance from upstream face.

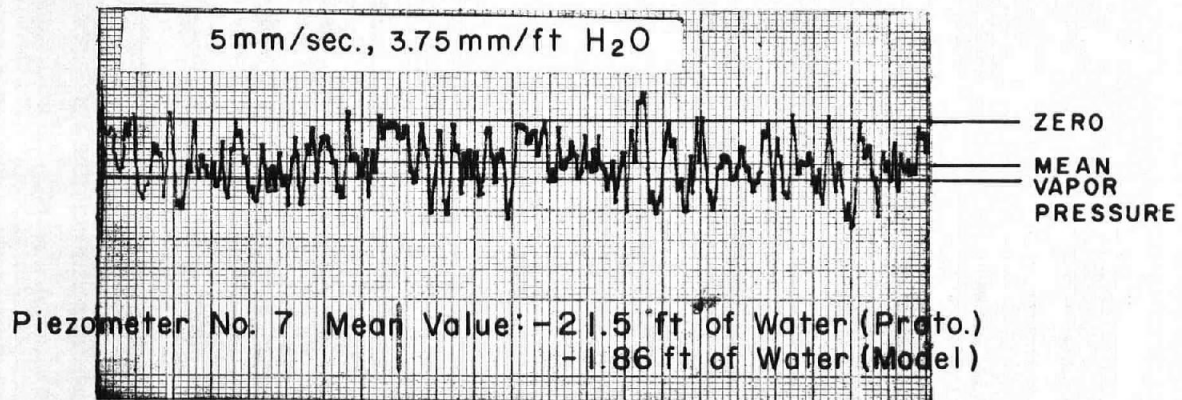
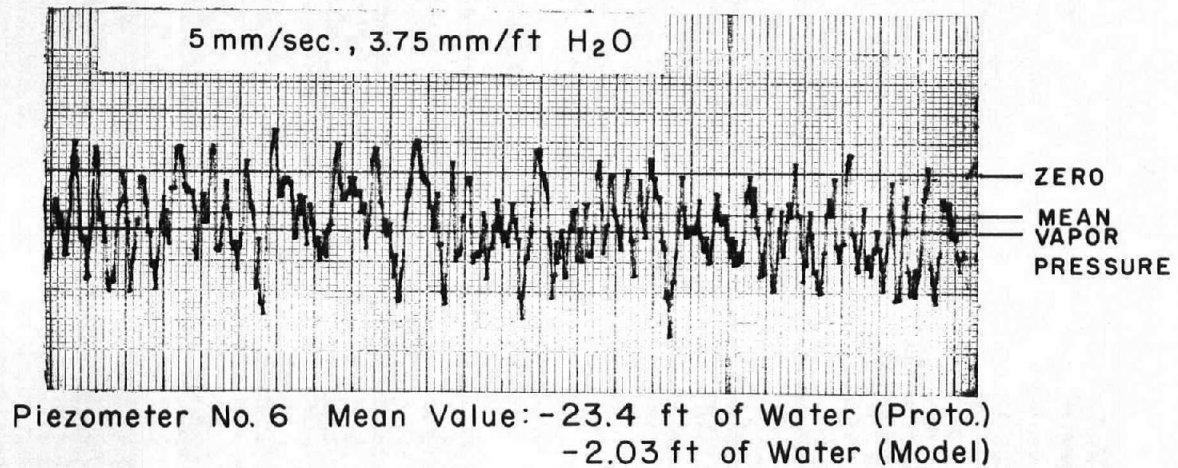
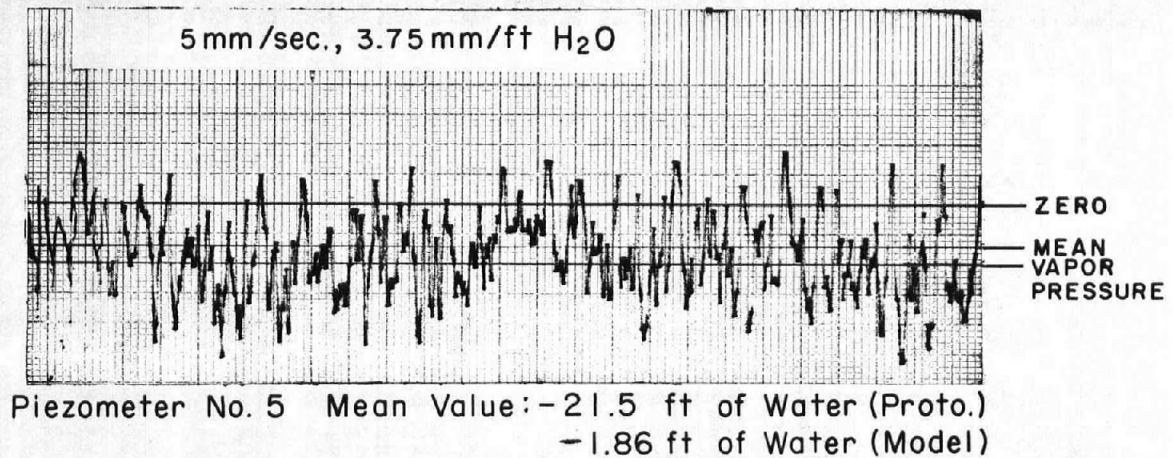

Figure 16. - Strip chart records for piezometers 5, 6, and 7; discharge 480 ft³/s (13.6 m³/s), upstream head 242.4 ft (73.9 m), gate opening 13.7 percent.

vapor cavities could form along the top, then collapse on the backside of the baffle pier, and cause damage.

The baffle pier was modified, figure 17, to minimize the possibility of cavitation damage. This shape is recommended to replace the original design. Pressure data from piezometers 1, 2, and 3 on the modified pier are shown in figure 18 and as a dashed line on figure 15. The pressure is below vapor pressure less than 5 percent of the time.

If any vapor cavities form across the top of this baffle pier during the time when the pressure is less than vapor pressure, they should collapse in the water behind the pier because the flow did not follow the profile of the baffle pier as the flow did for the rounded topped baffle pier. The flow moved downstream from the trailing edges of the baffle pier and did not contact the surface again.

Initially, the baffle piers were tested in their original position, then tests were conducted with the piers at locations 5 and 10 feet (1.5 and 3.0 m) closer to the gate. Little change in the effectiveness of the baffle piers could be observed as they were moved closer to the gate. However, mean pressures equivalent to about 20 feet (6.1 m) to 23 feet (7.0 m) of water below atmospheric were

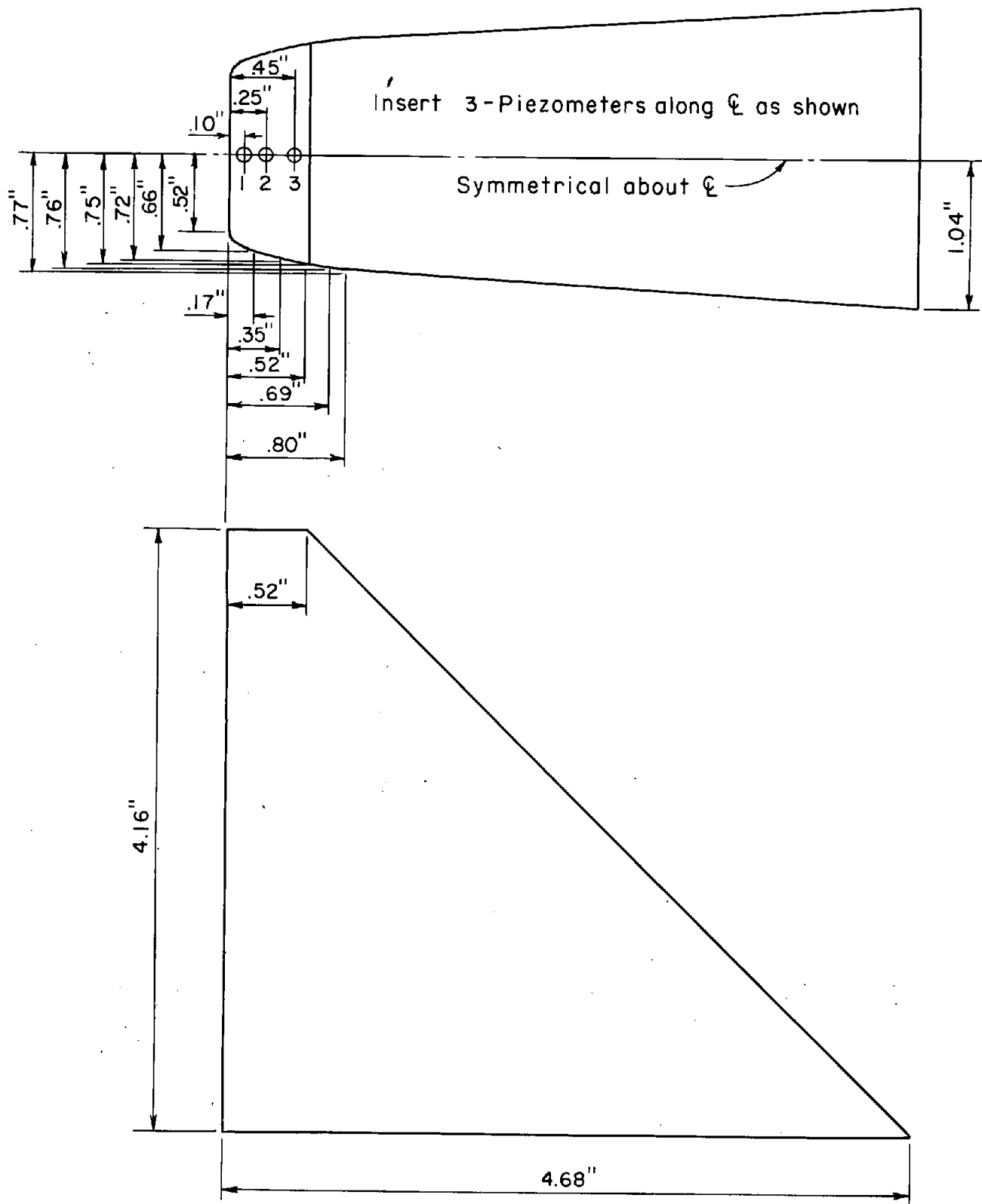
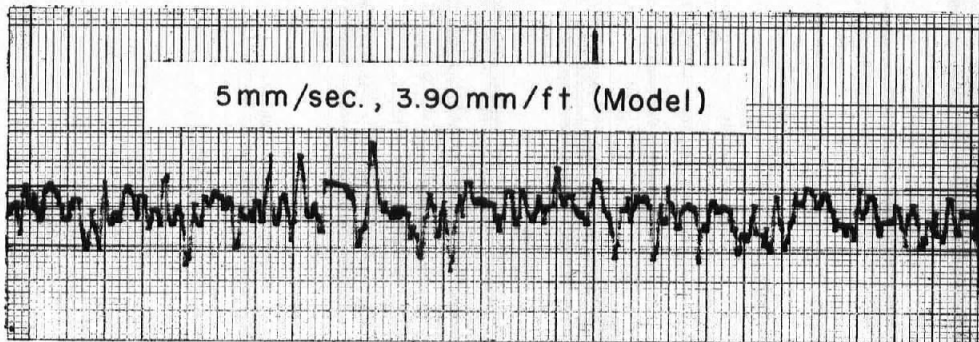
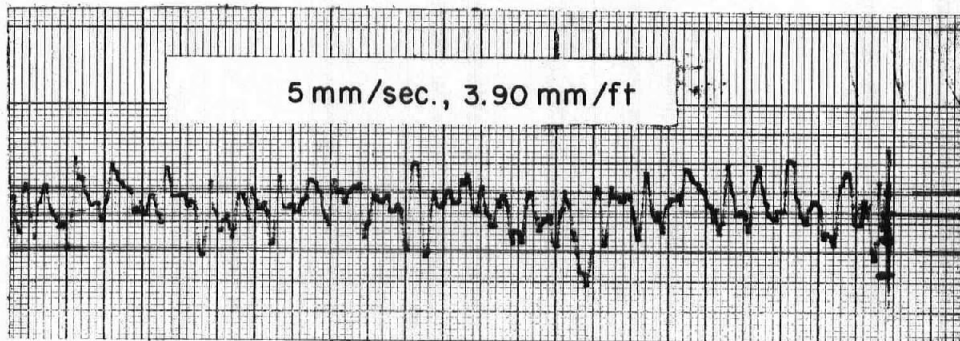

Figure 17. - Modified baffle pier showing location of piezometers.



Piezometer No. 1 Mean Value: -10.65 ft of Water (Proto.)
-0.92 ft of Water (Model)



Piezometer No. 2 Mean Value: -13.31 ft of Water (Proto.)
-1.15 ft of Water (Model)

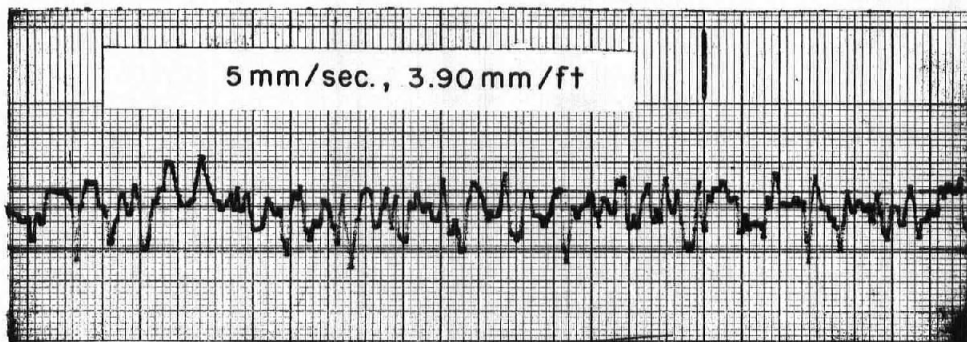

Piezometer No. 3 Mean Value - 9.76 ft of Water (Proto.)
-0.85 ft of Water (Model)

Figure 18. - Strip chart records for modified piers, piezometers 1, 2 and 3; discharge 480 ft³/s (13.6 m³/s), upstream head 242.4 ft (73.9 m), gate opening 13.7 percent.

observed across the top of the pier with the pier placed 5 feet upstream from the original position. Consequently, it was concluded that the piers could not be moved upstream without possibly creating cavitation problems along the top of the baffle piers.

The point of curvature of the downstream end of the stilling basin is 9.5 feet (2.9 m) from the downstream end of the baffle piers. Any distance much less than this will affect the flow around the baffle piers and will probably reduce the energy dissipation of the stilling basin. Hence, the length of the stilling basin cannot be decreased without causing adverse affects on the energy dissipation.

Wave suppressors. - A series of beams 2 feet square were placed 2.75 feet (0.84 m) apart with the top of the beams 20.4 feet (6.22 m) above the stilling basin floor to minimize the passage of horizontal surges into the downstream tunnel. Waves were damped by an underpass wave suppressor located downstream from the beams, see figure 2. Both suppressors work very well for all flow conditions and no modifications are recommended.

Basin height and length. - The smallest possible size of stilling basin was desired to minimize excavation and the size of the structure required to support the poor quality rock that exists where the stilling basin will be constructed.

Model tests were performed to determine whether the size, either height or length, could be decreased and not affect the stilling basin performance. The stilling basin performance was not affected by decreasing the distance from the gate to the baffle piers. However, the length of the basin cannot be reduced because of the lower subatmospheric pressures measured on the baffle piers as they were moved toward the gate.

The water surface in the model was always well below the roof of the model. A sloping roof section was installed to determine whether the height of the basin could be decreased. This change did not alter the flow in the stilling basin. Accordingly, it is recommended that the height of the stilling basin be decreased by 5 feet (1.52 m) at the upstream end and sloped upward to intersect the original height at a point 72 feet (22 m) from the upstream end of the stilling basin. The roof section above the wave suppressor should not be modified.

Turbulent flow exists in the stilling basin for high heads and small gate openings; figure 13 is an example. For these conditions the high velocity jet almost sweeps the flow completely out of the gate section and then the flow surges upstream, which immediately causes rapid changes in pressure along the walls of the stilling basin. The velocity of the jet is between 115 and

120 ft/s (35.0 and 36.6 m/s) in the prototype and has a velocity head of about 200 feet (60.96 m) of water. The pressure changes along the walls may be equivalent to the full velocity head for the flow described above. These large, rapid changes in pressure require that the chute lining must be firmly anchored to the concrete so that vibration of the chute liner does not occur. The chute liner provides adequate protection to the floor and walls of the stilling basin, to a height of 4.5 feet (1.37 m). The zone of high shear flow continues to about 5 feet (1.52 m) above the floor. The velocities and pressure changes in the flow immediately above the liner should not cause any damage to the unlined concrete because they are much lower than the maximum values indicated above. Consequently, the height of the chute lining should remain at 4.5 feet (1.37 m).

ABSTRACT

Hydraulic model studies were conducted on a 1:11.54 scale model to assure satisfactory performance of the control structure for the Pacheco Tunnel, a segment of the San Felipe Division of the Central Valley project in West Central California. The initial design performed satisfactorily except for subatmospheric pressures downstream from the control gate and on the energy dissipator baffle piers. The subatmospheric pressures occurred only for heads above 220 feet (67.1 metres (m)) of water and gate openings between 3 and 8 percent. An elliptical section 6 inches (152 millimetres (mm)) wide was placed on both sidewalls downstream from the gate slot, which raised the pressures downstream from the gate. Also, the bypass was enlarged to a 20-inch (508-mm) pipe so that the gate would not be required to operate at gate openings less than 5 percent open. The potential cavitation pressures measured on the original round-top baffle pier were minimized by using a modified flattop baffle pier, which resulted in pressures only slightly below atmospheric.

ABSTRACT

Hydraulic model studies were conducted on a 1:11.54 scale model to assure satisfactory performance of the control structure for the Pacheco Tunnel, a segment of the San Felipe Division of the Central Valley project in West Central California. The initial design performed satisfactorily except for subatmospheric pressures downstream from the control gate and on the energy dissipator baffle piers. The subatmospheric pressures occurred only for heads above 220 feet (67.1 metres (m)) of water and gate openings between 3 and 8 percent. An elliptical section 6 inches (152 millimetres (mm)) wide was placed on both sidewalls downstream from the gate slot, which raised the pressures downstream from the gate. Also, the bypass was enlarged to a 20-inch (508-mm) pipe so that the gate would not be required to operate at gate openings less than 5 percent open. The potential cavitation pressures measured on the original round-top baffle pier were minimized by using a modified flattop baffle pier, which resulted in pressures only slightly below atmospheric.

ABSTRACT

Hydraulic model studies were conducted on a 1:11.54 scale model to assure satisfactory performance of the control structure for the Pacheco Tunnel, a segment of the San Felipe Division of the Central Valley project in West Central California. The initial design performed satisfactorily except for subatmospheric pressures downstream from the control gate and on the energy dissipator baffle piers. The subatmospheric pressures occurred only for heads above 220 feet (67.1 metres (m)) of water and gate openings between 3 and 8 percent. An elliptical section 6 inches (152 millimetres (mm)) wide was placed on both sidewalls downstream from the gate slot, which raised the pressures downstream from the gate. Also, the bypass was enlarged to a 20-inch (508-mm) pipe so that the gate would not be required to operate at gate openings less than 5 percent open. The potential cavitation pressures measured on the original round-top baffle pier were minimized by using a modified flattop baffle pier, which resulted in pressures only slightly below atmospheric.

ABSTRACT

Hydraulic model studies were conducted on a 1:11.54 scale model to assure satisfactory performance of the control structure for the Pacheco Tunnel, a segment of the San Felipe Division of the Central Valley project in West Central California. The initial design performed satisfactorily except for subatmospheric pressures downstream from the control gate and on the energy dissipator baffle piers. The subatmospheric pressures occurred only for heads above 220 feet (67.1 metres (m)) of water and gate openings between 3 and 8 percent. An elliptical section 6 inches (152 millimetres (mm)) wide was placed on both sidewalls downstream from the gate slot, which raised the pressures downstream from the gate. Also, the bypass was enlarged to a 20-inch (508-mm) pipe so that the gate would not be required to operate at gate openings less than 5 percent open. The potential cavitation pressures measured on the original round-top baffle pier were minimized by using a modified flattop baffle pier, which resulted in pressures only slightly below atmospheric.

GR-18-76

George, R. L.

Hydraulic Model Studies for the Pacheco Tunnel Energy Dissipator
Bur Reclam Rep GR-18-76, Div Gen Res, Sept 1976. Bureau of
Reclamation, Denver, 39 p, 18 fig, 2 tab

DESCRIPTORS--/ hydraulic models/ *slide gates/ *baffle piers/
*stilling basins/ *energy dissipation/ hydraulic jump/ model
studies/ cavitation/ subatmospheric pressure/ tunnel hydraulics/
design criteria/ flow control/ hydraulic structures/ discharge
(water)

IDENTIFIERS--/ subsurface energy dissipation structures/ Pacheco
Tunnel, CA

COSATI Field/Group 13M COWRR: 1313.1

GR-18-76

George, R. L.

Hydraulic Model Studies for the Pacheco Tunnel Energy Dissipator
Bur Reclam Rep GR-18-76, Div Gen Res, Sept 1976. Bureau of
Reclamation, Denver, 39 p, 18 fig, 2 tab

DESCRIPTORS--/ hydraulic models/ *slide gates/ *baffle piers/
*stilling basins/ *energy dissipation/ hydraulic jump/ model
studies/ cavitation/ subatmospheric pressure/ tunnel hydraulics/
design criteria/ flow control/ hydraulic structures/ discharge
(water)

IDENTIFIERS--/ subsurface energy dissipation structures/ Pacheco
Tunnel, CA

COSATI Field/Group 13M COWRR: 1313.1

GR-18-76

George, R. L.

Hydraulic Model Studies for the Pacheco Tunnel Energy Dissipator
Bur Reclam Rep GR-18-76, Div Gen Res, Sept 1976. Bureau of
Reclamation, Denver, 39 p, 18 fig, 2 tab

DESCRIPTORS--/ hydraulic models/ *slide gates/ *baffle piers/
*stilling basins/ *energy dissipation/ hydraulic jump/ model
studies/ cavitation/ subatmospheric pressure/ tunnel hydraulics/
design criteria/ flow control/ hydraulic structures/ discharge
(water)

IDENTIFIERS--/ subsurface energy dissipation structures/ Pacheco
Tunnel, CA

COSATI Field/Group 13M COWRR: 1313.1

GR-18-76

George, R. L.

Hydraulic Model Studies for the Pacheco Tunnel Energy Dissipator
Bur Reclam Rep GR-18-76, Div Gen Res, Sept 1976. Bureau of
Reclamation, Denver, 39 p, 18 fig, 2 tab

DESCRIPTORS--/ hydraulic models/ *slide gates/ *baffle piers/
*stilling basins/ *energy dissipation/ hydraulic jump/ model
studies/ cavitation/ subatmospheric pressure/ tunnel hydraulics/
design criteria/ flow control/ hydraulic structures/ discharge
(water)

IDENTIFIERS--/ subsurface energy dissipation structures/ Pacheco
Tunnel, CA

COSATI Field/Group 13M COWRR: 1313.1