



— BUREAU OF —  
RECLAMATION

# Facilities Instructions, Standards, and Techniques – Volume 2-1

## Alignment of Rotating Machinery



FIST Volume 2-1  
Alignment of Rotating Machinery

**Cover Photo**

Bureau of Reclamation, Typical Plumb Wire Setup

(FIST 007) 08/02/2016

NEW RELEASE

(Minor revisions approved 09/16/2016, 05/29/2024)

# **Facilities Instructions, Standards, and Techniques – Volume 2-1**

## **Alignment of Rotating Machinery**

Prepared by

**Power Resources Office  
and  
Technical Service Center**

U.S. Department of the Interior  
Bureau of Reclamation  
Power Resources Office  
Denver, Colorado

May 2024

## Mission Statements

The U.S. Department of the Interior protects and manages the Nation's natural resources and cultural heritage; provides scientific and other information about those resources; honors its trust responsibilities or special commitments to American Indians, Alaska Natives, Native Hawaiians, and affiliated Island Communities.

The mission of the Bureau of Reclamation is to manage, develop, and protect water and related resources in an environmentally and economically sound manner in the interest of the American public.

## Disclaimer

This written material consists of general information for internal use only by Bureau of Reclamation operations and maintenance staff. Information contained in this document regarding commercial products or firms may not be used for advertising or promotional purposes and is not to be construed as an endorsement or depreciation of any product or firm by the Bureau of Reclamation.

(FIST 007) 08/02/2016  
NEW RELEASE

# Contents

	Page
Codes and Standards.....	vi
Reclamation Standards and Documents.....	vi
Reclamation Forms.....	vi
References.....	vi
Acronyms and Abbreviations.....	vii
Symbols.....	vii
1.0 Introduction.....	1
1.1 Purpose and Scope.....	1
1.2 Reclamation Standard Practices.....	1
1.3 Manufacturer Recommendations.....	2
1.4 FIST Revision Requests.....	2
2.0 Vertical-Shaft Units – Hydroelectric and Large Pump Units.....	3
2.1 Description of Vertical-Shaft Hydroelectric and Large Pump Units.....	3
2.1.1 Thrust Bearings.....	5
2.1.2 Thrust Block.....	7
2.1.3 Thrust Bearing High-Pressure Oil Lift System.....	10
2.1.4 Guide Bearings.....	11
2.2 Objectives of Vertical-Shaft Alignment.....	14
2.2.1 Concentricity.....	15
2.2.2 Circularity.....	16
2.2.3 Concentricity and Circularity as Applied to Generator Air Gap.....	16
2.2.4 Perpendicularity.....	18
2.2.5 Plumb.....	19
2.2.6 Straightness.....	20
2.3 Required Equipment.....	21
2.3.1 Plumb Wires.....	22
2.3.2 Laser Systems.....	25
2.3.3 Precision Levels.....	26
2.4 Basic Measurements.....	28
2.4.1 Preliminary Checks for All Units.....	28
2.4.2 Static Runout.....	31
2.4.3 Plumb Readings.....	37
2.4.4 Clearance and Concentricity Readings.....	39
2.5 Plotting the Data.....	40
2.5.1 Plumb and Runout Data.....	40
2.6 Alignment Procedures.....	49
2.6.1 General.....	49
2.6.2 Correcting Excessive Dogleg and Offset.....	50
2.6.3 Correcting Excessive Static Runout.....	51
2.6.4 Procedure for Spring-Loaded Thrust Bearings.....	52
2.6.5 Procedures for Adjustable Shoe Thrust Bearing.....	56

Alignment of Rotating Machinery

2.6.6	Procedure for Self-Equalizing Thrust Bearing .....	62
2.7	Guide Bearing Installation and Adjustment.....	63
2.7.1	Sleeve-Type Journal Bearings .....	64
2.7.2	Adjustable Shoe Bearings.....	65
2.7.3	Final Assembly and Startup.....	67
3.0	Horizontal Shaft Units – Hydroelectric and Large Pump Units .....	70
4.0	Vertical Shaft Auxiliary Equipment .....	71
5.0	Horizontal Shaft Auxiliary Equipment .....	72
5.1	Horizontal Shaft Alignment.....	72
5.1.1	Face and Rim Alignment Method.....	74
5.1.2	Reverse Indicator Method.....	79

**Tables**

Table 1.—Tolerances for vertical-shaft unit assembly.....	15
---	----

**Figures**

Figure 1.—Underhung hydroelectric unit example. ....	4
Figure 2.—Umbrella hydroelectric unit example. ....	5
Figure 3.—Adjustable shoe bearing. ....	6
Figure 4.—Spring-supported bearing. ....	7
Figure 5.—Self-equalizing thrust bearing.....	7
Figure 6.—Thrust block.....	9
Figure 7.—Clamp bar type thrust block. ....	10
Figure 8.—Thrust bearing high-pressure port. ....	10
Figure 9.—Typical sleeve type turbine bearing.....	12
Figure 10.—Typical segmented shoe guide bearing.....	13
Figure 11.—Thrust bearing perpendicularity and level.....	18
Figure 12.—Static runout.....	19
Figure 13.—Shaft offset and dogleg.....	21
Figure 14.—Plumb wire setup. ....	22
Figure 15.—Electric micrometer. ....	22
Figure 16.—Example of unit alignment worksheet (wires or laser system).....	25
Figure 17.—Laser system. ....	25
Figure 18.—Target for laser system. ....	26
Figure 19.—Precision level with magnetic base.....	27
Figure 20.—Precision level attached to shaft with strap. ....	27
Figure 21.—(Part 2 of 2) Runout worksheet (wire or laser system).....	34
Figure 22.—Runout data and plot (wire or laser system).....	35
Figure 23.—Runout using dial indicators at two elevations.....	36
Figure 24.—Plot of shaft centerline.....	39
Figure 25.—Alignment worksheet (precision level). ....	45

Figure 26.—Runout using indicators at three elevations..... 46  
Figure 27.—Shaft and center of runout plumb plot (precision level)..... 49  
Figure 28.—Graphical procedure for shim calculation (shim thickness in mils). .... 55  
Figure 29.—Analytical procedure for shim calculation (shim thickness in mils). .... 56  
Figure 30.—Adjustable shoe thrust bearing loading readings and plot..... 59  
Figure 31.—Actual bearing clearances. .... 67  
Figure 32.—Orbit and FFT plots. .... 69  
Figure 33.—Checking indicator bar for sag. .... 74  
Figure 34.—Face and rim alignment method. .... 75  
Figure 35.—Face and rim alignment worksheet example. .... 76  
Figure 36.—Reverse indicator alignment worksheet (example). .... 81  
Figure 37.—Reverse indicator alignment plot..... 82

**Appendices**

- A Blank Forms for Alignment of Vertical-Shaft Hydroelectric and Large Pump Units
- B Blank Forms for Alignment of Horizontal Shaft Hydroelectric and Large Pump Units
- C Blank Forms for Alignment of Vertical Shaft Auxiliary Equipment
- D Blank Forms for Alignment of Horizontal Shaft Auxiliary Equipment

## Codes and Standards

None

## Reclamation Standards and Documents

FAC 04-14	Power Facilities Technical Documents
FAC P04	Hydroelectric Power
FIST 2-4	Lubrication of Powerplant Equipment
FIST 2-7	Mechanical Overhaul Procedures for Hydroelectric Units
FIST 2-12	Mechanical Maintenance of Hydroelectric and Large Pump Units
FIST 3-11	Generator Thrust Bearing and Oil Film Resistance

## Reclamation Forms

POM: <https://teamssp.bor.doi.net/printanddup/forms/POM%20Forms/Forms/AllItems.aspx>

POM-226, FIST Revision Request

POM-300, FIST Variance Form

## References

None



## Acronyms and Abbreviations

FIST	Facilities Instructions, Standards, and Techniques
FFT	fast Fourier transform
LGB	lower (generator) guide bearing
mil	thousandth of an inch
O&M	Operations and Maintenance
PO&M	Power Operations and Maintenance
PRO	Power Resources Office
Reclamation	Bureau of Reclamation
TGB	turbine guide bearing
TSC	Technical Service Center
UGB	upper (generator) guide bearing

## Symbols

°	degrees
>	greater than
<	less than
%	percent
+	plus
±	plus or minus

**This page intentionally left blank.**

# 1.0 Introduction

The Bureau of Reclamation (Reclamation) operates and maintains 53 hydroelectric powerplants and many switchyards, pumping plants, and associated facilities in the 17 Western United States. These facilities are critical to the electric power and water delivery systems relied on by many. They house complex electrical and mechanical equipment that must be kept operational. Proper shaft alignment provides longer life of key components and overall reliability of the units.

## 1.1 Purpose and Scope

This document is intended to promote uniformity in the manner that assets are managed, documented, and coordinated, and may be utilized by transferred facilities and other entities as appropriate. It establishes consistent procedures, minimum standards and Operations and Maintenance (O&M) criteria for equipment and systems owned and operated by Reclamation. Other technical documents may provide additional electrical and mechanical maintenance information for the equipment or systems discussed in this document.

The O&M requirements are based on industry standards and experience. Maintenance requirements vary based on equipment condition and past performance, and sound engineering practices and maintenance management should be employed for special circumstances. Manufacturer recommendations and instructions should be consulted for additional maintenance that may be required beyond what is stated in this manual.

The purpose of this document is to provide information and procedures for aligning rotating machinery. The proper alignment of rotating machinery is important for long-term reliable operation. Assembly within recommended tolerances will equalize loading and cyclic forces on the thrust bearings and reduce forces on guide bearings.

Information within this document includes vertical and horizontal shaft units used in hydroelectric and large pumps units, and auxiliary equipment (e.g., cooling water/sump/fire protection pumps, motor-to-gearbox, etc.) roles. Large pumps are custom designed and manufactured equipment that are site specific. Small pumps used for auxiliary systems or water conveyance are typically pre-designed commercially available equipment that may be selected to best suit a site or system.

## 1.2 Reclamation Standard Practices

Facilities Instructions, Standards, and Techniques (FIST) manuals are designed to provide guidance for maintenance and testing on equipment in Reclamation's facilities. There may be multiple ways to accomplish tasks outlined in this document. Facilities may exercise discretion as to how to accomplish certain tasks based on equipment configurations and available resources.

Reclamation's regions, Power Resources Office (PRO), and Technical Service Center (TSC) agree that certain practices are required to be consistent across all Reclamation facilities. Mandatory FIST procedures, practices, and schedules that appear in **{Red, bold, and bracketed}** or **[Black, bold, and bracketed]** text are considered Reclamation requirements for the O&M of equipment in power facilities. RM D&S FAC 04-14, *Power Facilities Technical Documents*, describes the responsibilities required by text designations: **{Red, bold, and bracketed}**, **[Black, bold, and bracketed]**, and plain text, within this technical document. Refer to RM D&S FAC 04-14 for more details concerning technical documents.

Refer to RM D&S FAC 04-14 for more details concerning technical documents.

### 1.3 Manufacturer Recommendations

FIST manuals are designed to provide guidance for maintenance and testing on equipment in Reclamation's facilities. Due to the vast difference in equipment design, consultation of equipment owner's manual and manufacturer recommended maintenance should be conducted when developing job plans. For new equipment not following the manufacturer guidance may void the warranty. If there is a discrepancy between the FIST and the manufacturer recommendations, the more stringent shall be adopted in the job plan; unless there is a reason that a less restrictive maintenance practice is warranted which, the variance or deviation process as outlined in Reclamation Manual FAC 04-14 must be followed.

### 1.4 FIST Revision Requests

The FIST Revision Request Form (POM-226) is used to request changes to a FIST document. The request will include a summary of the recommended changes and a basis for the revision or new FIST. These forms will be submitted to the Manager, Power Resources Office. The PRO Manager will keep a list of Revision Requests for each FIST and include these in the next scheduled revision unless it is so important the change is priorities sooner.

## 2.0 Vertical-Shaft Units – Hydroelectric and Large Pump Units

This section covers alignment of hydroelectric and large pump units as discussed in section 1.1.

---

**Note: The information in this section uses terminology of a hydroelectric turbine. Terminology of components may be slightly different if procedures and worksheets are being utilized for alignment of a large pump.**

---

### 2.1 Description of Vertical-Shaft Hydroelectric and Large Pump Units

The proper alignment of the subject units is important for long-term reliable operation. Assembly within recommended tolerances will equalize loading and cyclic forces on the thrust bearings and reduce forces on guide bearings. The purpose of this document is to provide enough information to allow the alignment of a unit within acceptable limits.

To better understand the procedures used for alignment, it is important to understand the basic construction of these units. Figure 1 shows the generator of a typical underhung hydroelectric unit as an example. It has a thrust bearing located above the rotor and also has upper and lower generator guide bearings. Typically, the upper guide bearing is located just above the thrust bearing. In many cases, the outer circumference of the thrust runner serves as the upper guide bearing journal, although some units, usually those larger than 50 megawatts, may have a separate upper guide bearing journal on the shaft, located below the thrust bearing. The rotating weight of the unit is transferred through the thrust bearing, through the upper bridge, and through the stator frame to the foundation. The lower bridge supports the lower generator guide bearing and is capable of supporting the weight of the unit when it is supported by the jacks.

Figure 2 shows an umbrella unit, in which the thrust bearing is located below the rotor. In the umbrella unit, the rotating weight is transferred to the foundation through the lower bridge. The jacks are also attached to the lower bridge. The upper bridge supports only the deck plates and the upper guide bearing, if there is one. Since the stator frame does not have to support the weight of the unit, it does not have to be as heavy as the frame of an underhung unit. Both figures 1 and 2 are very general sketches of generators provided as an example, and while most vertical units will resemble one of the figures, the specific construction and design details vary between manufacturers. Understanding these design details, particularly the bearing designs, is critical in developing a working alignment procedure. Listed below are descriptions of some of the components most closely associated with the unit alignment.

FIST Volume 2-1  
Alignment of Rotating Machinery

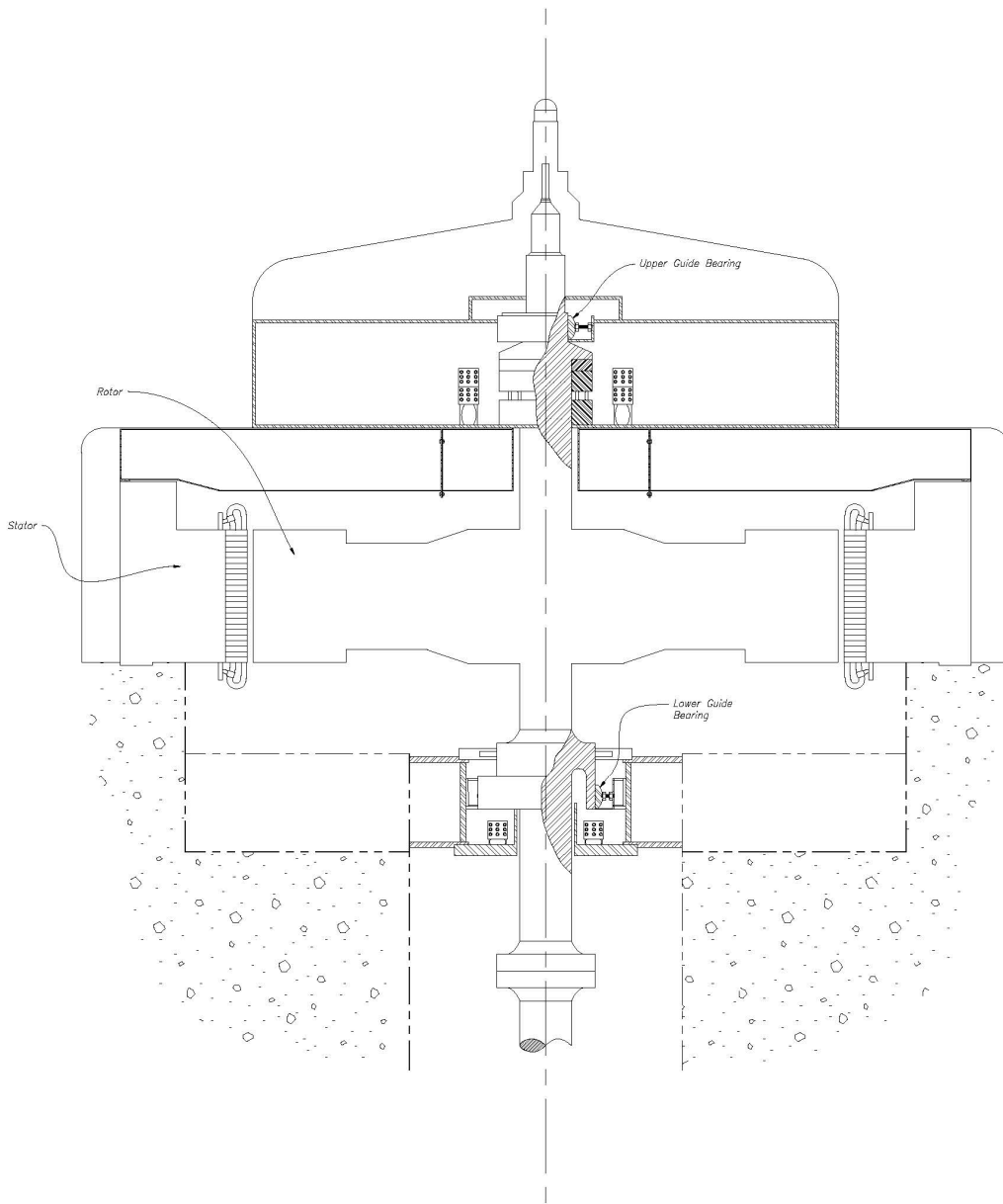

Figure 1.—Underhung hydroelectric unit example.

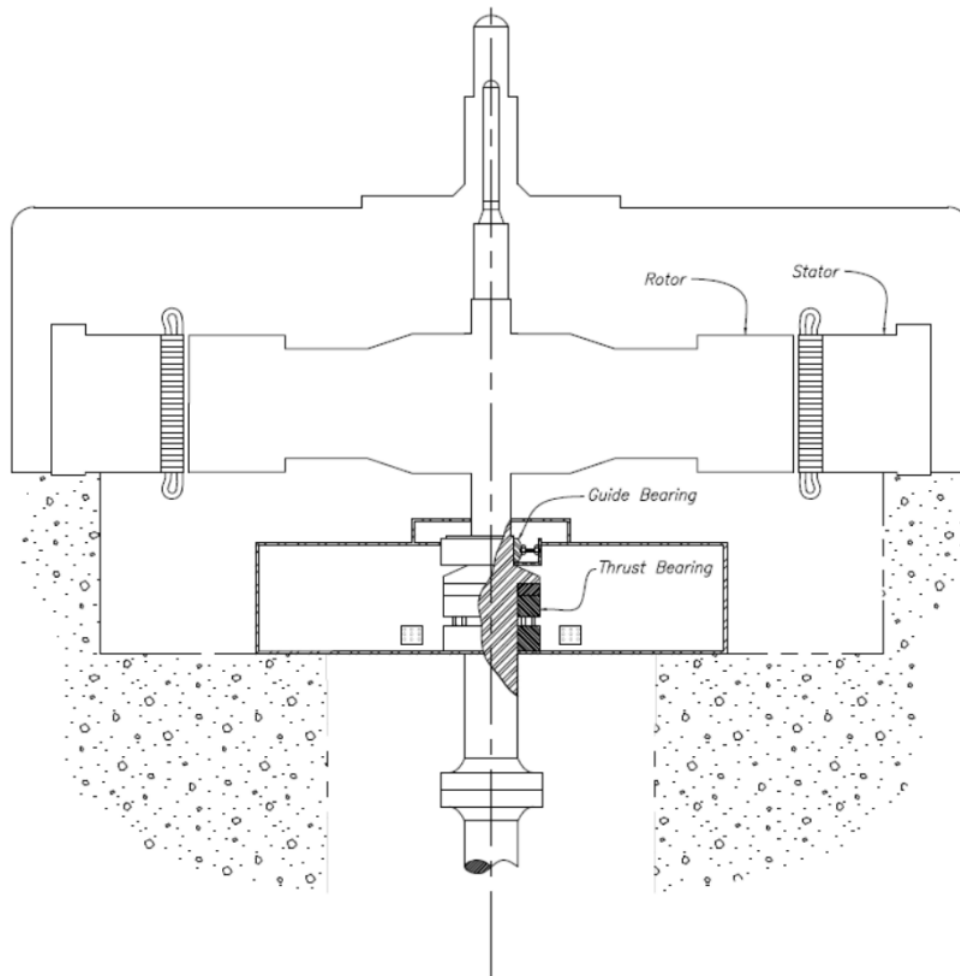

Figure 2.—Umbrella hydroelectric unit example.

### 2.1.1 Thrust Bearings

Thrust bearings support the axial load on a rotating shaft. On a vertical-shaft unit, the thrust bearing supports the entire rotating weight of the unit, as well as any hydraulic downthrust from the turbine. There are typically three types of thrust bearings used: the adjustable shoe, the spring-supported, and the self-equalizing. All three bearing types look very similar. All three use Babbitt-lined, pie-shaped bearing shoes that are designed to tilt slightly to allow a wedge of oil to form between the shoes and the thrust runner. The differences lie in the supporting structure for the bearing shoes. The design of the thrust bearing is used to determine the procedure used to align the unit.

The adjustable shoe thrust bearing uses a jack screw under each of the shoes for adjusting the height and loading of the shoes. Figure 3 illustrates the basic components. A pivot point on top of each of the jack screws allows the shoe to pivot freely and form the required oil wedge.

Variations of the adjustable shoe thrust bearing may have load cells or other means of measuring the load on each bearing shoe.

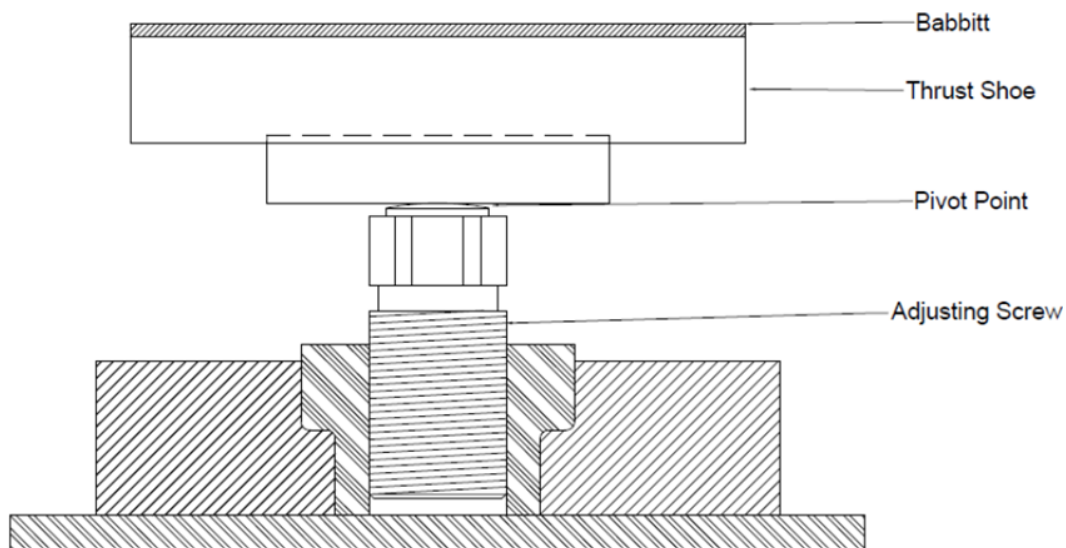

Figure 3.—Adjustable shoe bearing.

The spring-supported thrust bearing consists of the bearing shoes supported by some type of spring. The spring support may be a number of coil springs, flat plates of spring steel, Belleville washers, or a Y-shaped bracket that acts as a spring. Coil spring-supported bearings are the most common type of spring-supported thrust bearing. They have several coil springs on the baseplate, as shown on figure 4. The springs are usually preloaded to a point that there is little deflection results from the static weight of the rotating parts that they support. With the addition of the hydraulic downthrust of the turbine, the springs will deflect to equalize the load between the shoes. The spring steel type uses a stack of several pieces of spring steel with a pivoting bearing shoe on top. The Belleville washer design uses a single Belleville washer or conical spring under each shoe. The Y-bracket type bearing uses a single Y bracket to support two shoes. The Y bracket acts as a spring to help equalize the load.



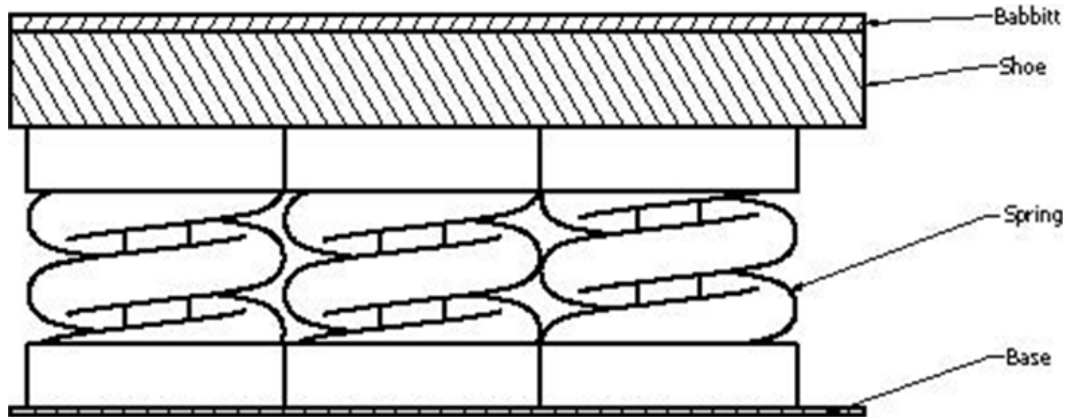

Figure 4.—Spring-supported bearing.

The self-equalizing bearing, as the name implies, is designed to automatically equalize the load between bearing shoes. Figure 5 is a simplified sketch of a self-equalizing bearing. The bearings consist of the bearing shoes, upper leveling plates, and lower leveling plates. The lower leveling plates rest on the baseplate on blunt pivot points that allow them to rock slightly. The upper leveling plates are each supported by two of the lower leveling plates. The bearing shoes are mounted on top of the upper leveling plates and are free to pivot as necessary to form the oil wedge. As can be seen on the figure, if one shoe is forced down due to higher loading, the lower leveling plates on each side of the depressed shoe will tilt slightly, lifting the shoes on either side of the depressed shoe. This action allows the self-equalizing bearing to maintain equal loading on all shoes even with slight inaccuracies in shoe thickness or alignment.

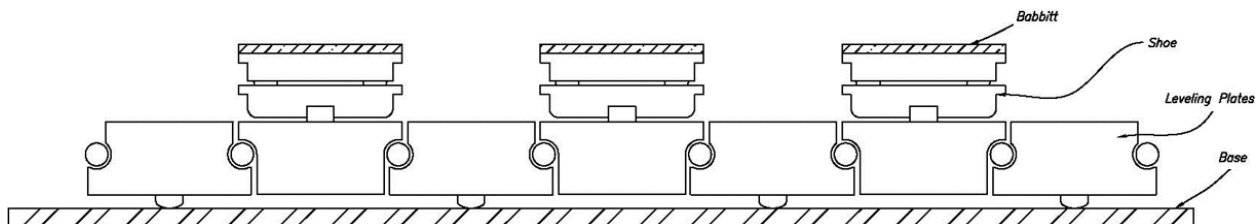

Figure 5.—Self-equalizing thrust bearing.

There may be types of thrust bearings other than those discussed. Typically, one of the procedures described here can be used once the function of the design is determined. Personnel unsure of how a particular thrust bearing is constructed should contact the Turbines and Pumps Group (86-68470) in the TSC.

### 2.1.2 Thrust Block

The two rotating components of a thrust bearing are the thrust block and the thrust runner. In most cases, these are separate parts. The thrust block is usually shrink-fitted onto the shaft and

FIST Volume 2-1  
Alignment of Rotating Machinery

the runner is bolted or doweled to the block. On umbrella units, the thrust block is usually an integral part of the shaft, and the thrust runner is split into two pieces. The bottom surface of the runner is highly polished to provide a mating surface for bearing shoes. In some instances, the outer diameter of the thrust runner is also polished to provide a bearing surface for a guide bearing. The purpose of having the runner separate from the block is to make it replaceable in the event it is damaged when a bearing fails.

There are a number of thrust block designs, but the most common is shown on figure 6. The block is keyed to the shaft with one or more axial keys and held onto the shaft with a split radial key. A solid keeper is usually placed over the radial keys to hold them in place. To remove this type of thrust block, the unit jacks are used to raise the generator rotor high enough to remove the weight of the unit from the thrust block. Then, depending on the design of the jacks, the jacks are locked in position, or blocks are installed to prevent the rotor from drifting down. The thrust block is then heated quickly using large propane torches or large “rosebud” type oxyacetylene torches. When the block is expanded sufficiently for removal, it will drop slightly, allowing the radial keys to be removed. The block can then be lifted off of the shaft. To install the thrust block, it is heated to a predetermined temperature calculated by an engineer and lowered over the shaft, again with the unit on the jacks. The block is set on the thrust shoes, the rigging removed, and the radial keys and keeper installed. With the block still hot, the jacks are released to allow the full weight of the unit to set the block in place against the keys.

Another type of thrust block found on Reclamation units is shown on figure 7. Like the previously described thrust block, this one also has an axial key between the block and the shaft, but this type of block is held to the shaft using a series of radial clamping keys. The keys clamp the block to a shoulder on the shaft. To remove this type of block, the unit is lifted and blocked on the jacks, the clamping keys are unbolted, and rigging to lift the block is attached. Before heating, a slight amount of tension is placed on the rigging so that the block will pop up slightly when it is loose. A crane scale should be used to prevent overloading the rigging. To install the block, it is heated to a predetermined temperature calculated by an engineer and lowered onto the shaft until it sets on the ledge on the shaft. The unit is to be placed on jacks and high enough to allow the thrust block to reach the ledge. The keys are then installed and the bolts torqued according to the manufacturer’s instructions.

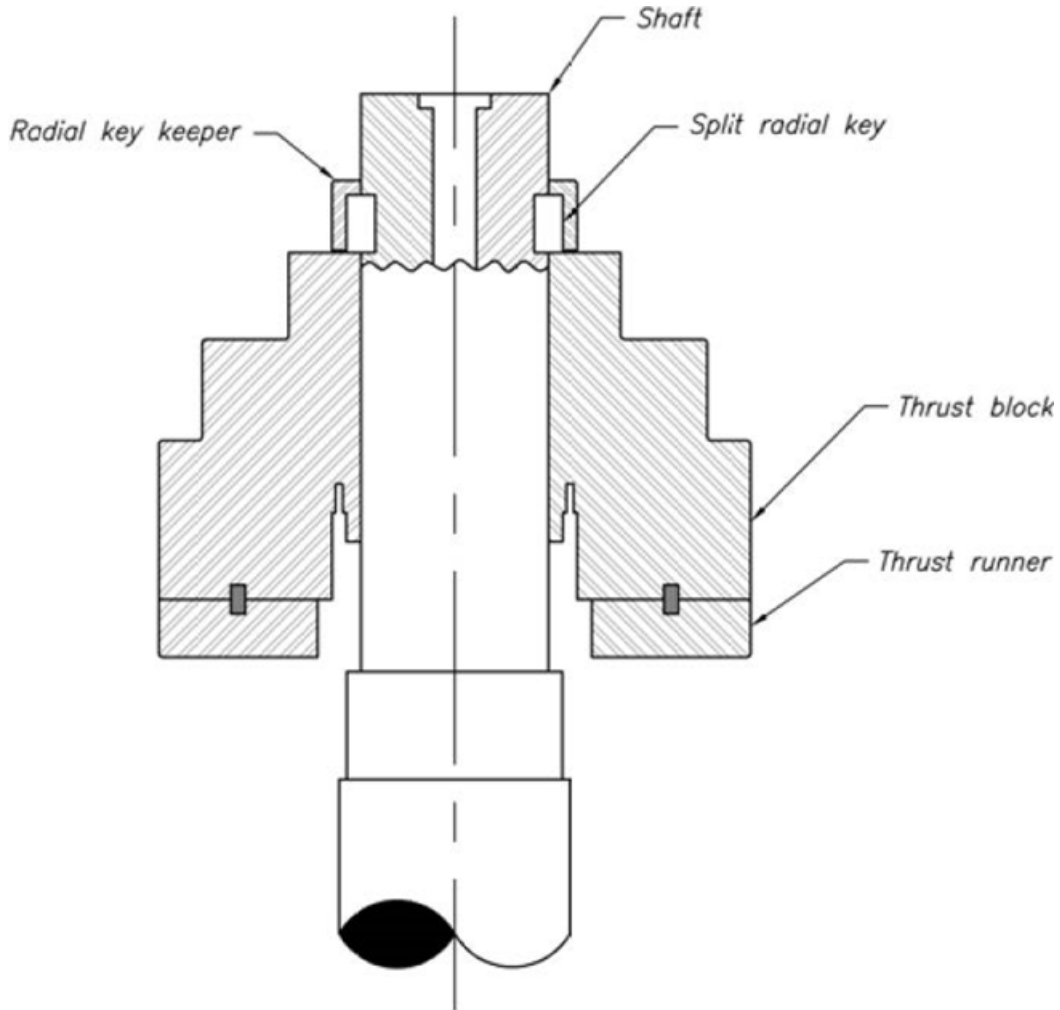

Figure 6.—Thrust block.

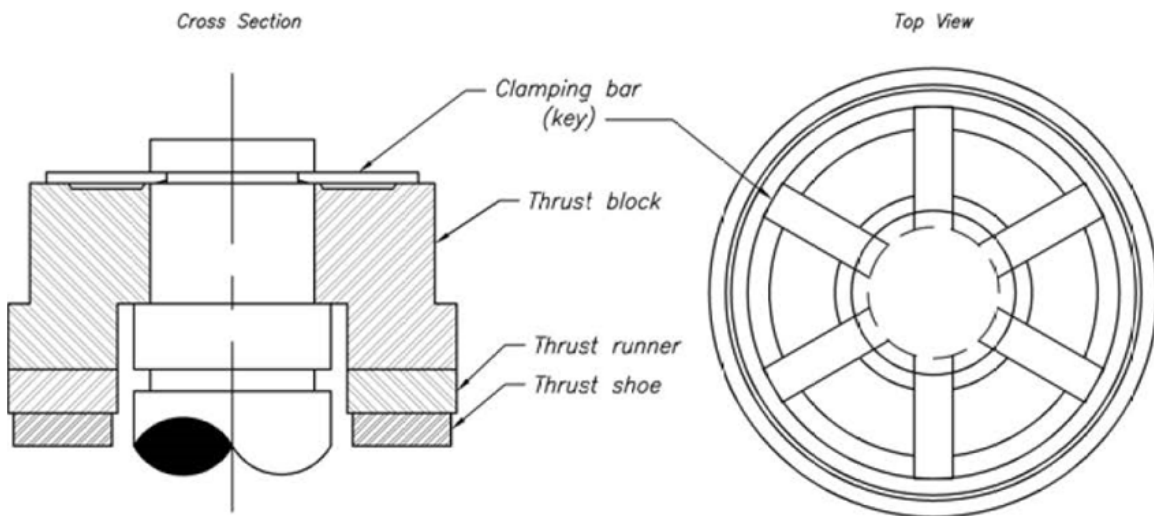

Figure 7.—Clamp bar type thrust block.

It should be noted that on some thrust block designs, the thrust runner is not bolted to the thrust block. In these cases, the thrust runner is secured to the block only by dowel pins. When the block is lifted, the runner may stay on the thrust shoes, or it may stick to the block due to the adhesion of the oil. If the runner sticks to the block, moving the block and runner together can create a dangerous situation. The runner can fall off at any time. With this type of design, it is best to separate the runner from the block while the unit is jacked up, so that only the block is lifted.

### 2.1.3 Thrust Bearing High-Pressure Oil Lift System

The thrust bearing high-pressure oil lift system injects high-pressure oil between the thrust shoes and the runner to provide lubrication on startup and shutdown of a unit. The oil is pumped from the bearing oil pot by a high-pressure pump, through a manifold to ports machined in each of the shoes. Figure 8 shows a typical oil ring on a thrust shoe for a high-pressure oil lift system. The primary use for this type of system is to establish an oil film between the thrust runner and shoes, which protects the bearing components and reduces friction during startup and shutdown. It is also a very useful system during alignment. With the system on, it is possible for a couple of people to rotate a unit by hand or move the rotating components laterally on a thrust bearing. Both rotation and lateral movement are required during the alignment process, which will be discussed later in this document.

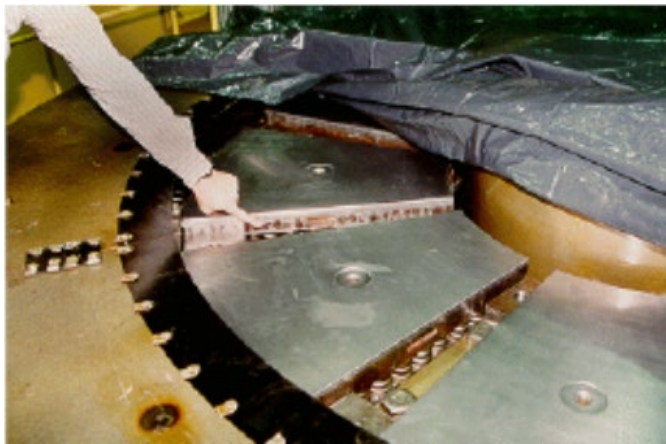

Figure 8.—Thrust bearing high-pressure port.

At times, it may not be possible to rotate a unit with the high-pressure oil lift system operating. If the unit is equipped with adjustable shoe thrust bearings, the unit may not rotate due to unbalanced loading of the thrust shoes. This can happen if the thrust bearing was disassembled during maintenance. This usually can be corrected by doing a rough adjustment on the shoes to load them more evenly.

In some cases, there may be a problem with the high-pressure oil lift system itself. It is possible for one or more of the supply hoses to break, preventing oil from getting to the thrust bearing. This type of failure isn't obvious unless the oil tub is exposed. Each line has a flow control valve so that the other shoe will still be supplied with oil and the overall system pressure will not change.

The system itself may need to be analyzed. If the pump flow and/or pressure has decreased due to wear or if the flow controls to each shoe are misadjusted, the system may not function as required. The system pressure should be evaluated as to whether it is higher or lower than has been noted in the past. Some adjustment of the pump bypass or pressure regulator may be required to increase pressure to the shoes. Reference FIST 2-12 Mechanical Maintenance of Hydroelectric and Large Pump Units for further detailed information.

If the shaft or other rotating components are not free, this can also prevent the unit from rotating easily. If the turbine runner is rubbing in the seal rings, there may be too much friction to allow the unit to rotate. Moving the unit laterally at the thrust bearing until the shaft is free should correct this problem. A centering device, such as a set of jacking bolts with rollers, may need to be installed to keep the shaft centered while rotating, or to re-center it after rotation.

If the thrust shoes are evenly loaded and the shaft is free but the unit still does not rotate readily by hand, the thrust bearing or thrust runner surface may be damaged. This typically would only occur during pre-teardown readings. The unit may operate satisfactorily but still require more force to rotate the unit than can be provided manually. In this case, it will be necessary to disassemble the unit without all the normal readings taken prior to teardown.

#### **2.1.4 Guide Bearings**

Guide bearings support the shaft radially and help hold the shaft in alignment. Ideally, the guide bearings in a vertical-shaft unit should be very lightly loaded. In reality, due to imperfect alignment, unbalance, hydraulic forces from the turbine, and other factors, the guide bearings can carry significant loads. The designs of guide bearings vary a great deal. The bearing surface is usually Babbitt metal, but some older units use water-lubricated lignum vitae, a hardwood, or high-density polyethylene bearings. The bearing may be a sleeve-type journal bearing with a cast steel shell (figure 9). Turbine bearings usually have a greater axial length than generator guide bearings. Turbine bearings are typically lubricated by an auxiliary pump that pumps oil to the top of the bearing. The oil then flows by gravity through the bearing. The turbine bearing may be held in place in the turbine bearing housing by dowels, or it may have a tapered fit that allows very little or no adjustment.

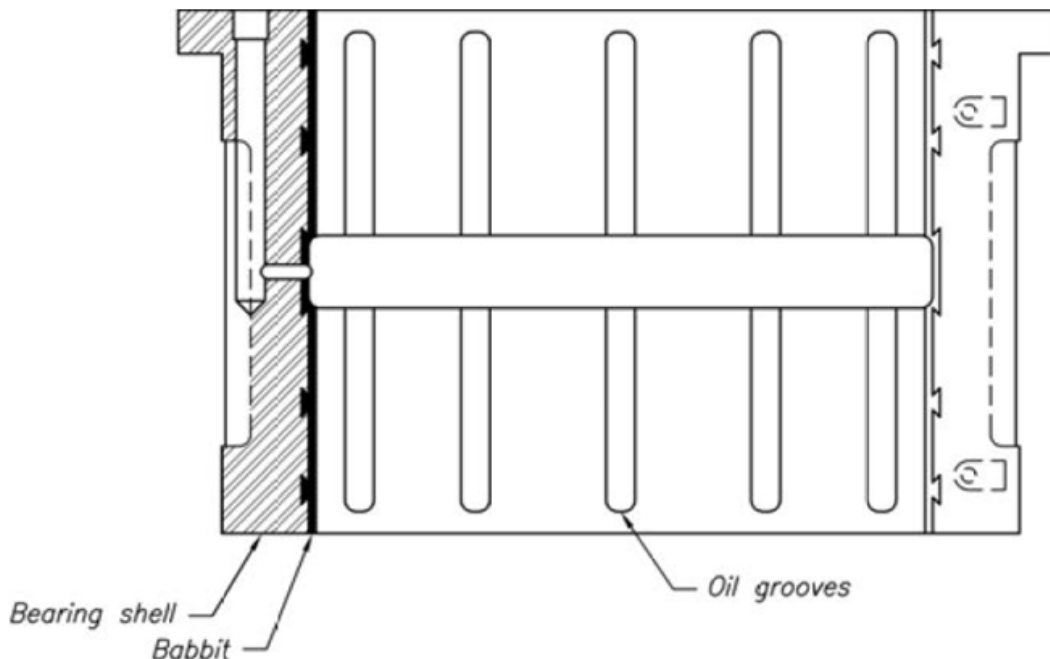

Figure 9.—Typical sleeve type turbine bearing.

The generator guide bearings may be sleeve-type journal bearings, or they may be made up of segmented shoes (figure 10). The axial length of the bearings is usually much less than the diameter.

The segmented shoe-type bearings allow for adjustment of the bearing clearance and the position of the center of the bearing. The sleeve-type journal bearing may be doweled in place, or the bearing shell may be a tight fit in the upper or lower bridge. Both the sleeve-type and the segmented shoe bearings used on generators are typically partially submerged in an oil bath and lubricated through the rotation of the shaft.

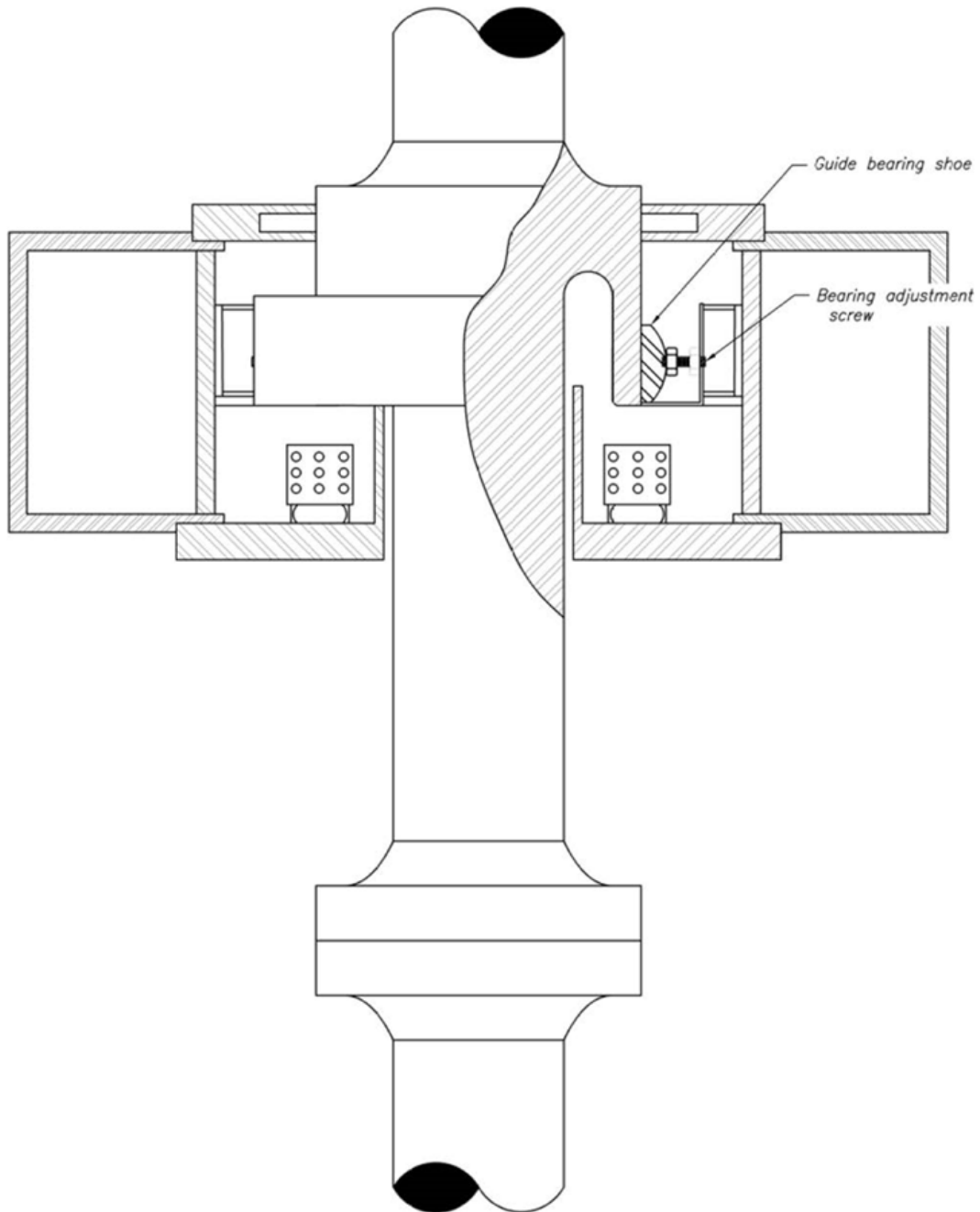

Figure 10.—Typical segmented shoe guide bearing.

## 2.2 Objectives of Vertical-Shaft Alignment

In a perfectly aligned vertical-shaft unit:

- The shaft would be straight,
- The thrust runner would be perpendicular to the shaft,
- The generator rotor and turbine would be round and concentric with the shaft,
- The thrust bearing shoes would be level and equally loaded,
- The stator, turbine seal rings, and guide bearings would be round, and
- Their centerlines would be concentric and plumb.

In this perfectly aligned unit, loading on the guide bearings would come primarily from any imbalance in the machine.

Perfection is not possible. Because manufacturing, fabrication, and measurement all introduce inaccuracies, and precise adjustments are not always possible, there will be deviations from a perfect alignment. The farther the alignment deviates from perfection, the more stress is introduced to the unit. Loading of the guide bearings, wear of pivot points, fatigue of springs in thrust bearings, and increased overall vibration levels can all result from misalignment.

Since a perfect alignment is not possible, guidelines or tolerances are needed to determine when the alignment is acceptable. Table 1 lists tolerances for use in aligning a vertical-shaft unit. These are general tolerances, and some judgment must be used in specific cases. In most cases, a unit can easily be aligned within these tolerances, but in some special circumstances, it may not be possible without major modification. When a major modification is required, the possible consequences of operating outside the tolerance should be considered before deciding whether to return the unit to operation.

To meet the tolerances of table 1, concentricity, straightness, perpendicularity, and plumb are to be addressed. The following sections provide definitions of these characteristics as they apply to vertical-shaft alignment.



**Table 1.—Tolerances for vertical-shaft unit assembly**

Measurement	Tolerance
Stator air gap	± 5% of nominal design air gap
Stator concentricity (relative to turbine guide bearing)	5% of nominal design air gap
Upper generator guide bearing concentricity (relative to turbine and lower generator guide bearing)	20% diametrical bearing clearance
Lower generator guide bearing concentricity (relative to turbine and upper generator guide bearing)	20% diametrical bearing clearance
Seal ring concentricity (relative to turbine guide bearing and each other)	10% diametrical seal ring clearance
Circularity of stator	± 5% of nominal design air gap
Circularity of rotor	± 5% of nominal design air gap
Stator verticality (relative to plumb)	± 5% of nominal design air gap
Rotor verticality (relative to generator shaft)	± 5% of nominal design air gap
Shaft straightness	No reading point deviates more than 0.003 inch from a straight line connecting the top and bottom reading point.
Static shaft runout (orbit diameter)	0.002 inch multiplied by the length of the shaft from the thrust bearing to the point of runout measurement divided by the diameter of the thrust runner. All measurements in inches.
Plumb of center of shaft runout	0.000025 multiplied by the length of the shaft from the highest plumb reading to the lowest plumb reading.

### 2.2.1 Concentricity

By definition, concentric refers to anything sharing a common center. In the alignment of a vertical-shaft unit, the stationary components are considered concentric when a single straight line can be drawn connecting the centers of all the components. Ideally, on a vertical-shaft machine, this straight line will be plumb.

The concentricity of the stationary components can be checked by measuring clearances. Alternatively, if the unit is completely disassembled, such as during an overhaul, a single tight wire or laser can be used as a plumb reference. Clearance measurements —i.e., bearing, turbine seal ring, and generator air gap — can be used to locate the components' centerlines with reference to the shaft. If the unit is disassembled, the upper and lower bridges and the head cover can be installed temporarily and a single tight wire hung through the unit. The concentricity is

determined by measuring from the stationary components to the wire. Laser systems can also be used to determine the relative position of the stationary components. If the centers are not within tolerance for concentricity, the movable components, such as the bearing brackets or, in some cases, the generator stator, are moved into concentricity with the non-movable components, such as the turbine seal rings, and re-dowelled.

### 2.2.2 Circularity

Circularity refers to the deviation of any circular part from a perfect circle. On the generator rotor or stator, the circularity is measured as a percent deviation of the diameter at any point from the nominal or average. This is referred to as roundness and the deviation as out-of-roundness.

On bearings, seal rings, and similar components, circularity is usually referenced as the out-of-roundness and is measured as the difference between the maximum and minimum diameters.

### 2.2.3 Concentricity and Circularity as Applied to Generator Air Gap

Both concentricity and circularity can affect the generator air gap. Ideally, a round rotor will be perfectly centered in a round stator. Any deviation should be less than the allowable tolerance at any given point. The deviation can result from the rotor being off-center or from having a non-circular rotor or stator. The generator air gap should be measured at the top and bottom in at least four positions, but preferably eight. The air gap at all measurement point should be within 5 percent of the average.

$$\frac{R_i - R_{ave}}{R_{ave}} 100 \leq \pm 5\%$$
$$R_{ave} = \frac{1}{n} \sum_{i=1}^n R_i$$

$n$  = number of readings  
 $R_i$  = measured air gap  
 $R_{ave}$  = average air gap

If the air gap is out of tolerance, usually all that is required is to simply center the rotor in the stator. This may require aligning the unit out of plumb, but it is difficult to accomplish. If the stator is not circular, major work on the stator may be required. Running the unit of tolerance may be feasible in certain circumstances.

When it appears that the air gap may be slightly out of tolerance, it is important to know the best center for both the rotor and the stator, and to try to make the two points coincident. The best centers for the rotor and stator can be calculated using the least-squares circle method. For the stator, measure the air gap for a specific rotor pole, as the generator rotor is rotated manually.

This can be accomplished by rotating in incremental steps, stopping the rotor, and physically measuring the air gap or by attaching an air gap proximity probe to the rotor pole and continuously recording air gap as the rotor is rotated. To find the best center for the rotor, the air gap is measured at a specific spot on the stator as each rotor pole passes by; this is typically at the narrowest gap between the stator and rotor. Again, this can be done by moving in steps and manually measuring, or by attaching an air gap proximity probe to the stator and continuously recording the air gap. The shaft should be constrained at the generator guide bearings as much as possible to limit any lateral movement within the bearing clearances. Any lateral movement at the upper and lower generator guide bearings should be recorded and subtracted from the air gap measurements. Once the data is collected, the best center for the data is calculated by the equations:

$$x = \frac{2}{n} \sum_{i=1}^n R_i \cos \theta_i$$

$$y = \frac{2}{n} \sum_{i=1}^n R_i \sin \theta_i$$

$$R = \frac{1}{n} \sum_{i=1}^n R_i$$

Where:

$R_i$  = measured air gap  
 $\theta$  = angle of measured air gap  
 $x, y$  = the coordinates of the best center of the least squares circle  
 $R$  = the radius of the least square circle or average air gap

The variation of circularity ( $\Delta$ ) from the average can be calculated from the equation:

$$\Delta = R_i - R - x \cos \theta - y \sin \theta$$

$$\frac{\Delta}{R} 100 = \text{percent out of roundness or circularity}$$

In general, the 5 percent tolerance for circularity is appropriate for both stators and rotors. An exception to this tolerance would be for the rotor of machines with Roebel bar windings. When a stator is wound with Roebel bars with one or two circuits, any eccentricity of the rotor can lead to uneven pulling on the rotor as the high spot passes by the different circuits. This uneven pull can lead to an unbalanced condition that is separate from any mechanical unbalance and can be

difficult to correct by balancing. If a rotor's non-circularity is causing high vibration levels in one of these machines, it may be necessary to install equalizing bars in the windings to equalize the circulating currents in the machine.

## 2.2.4 Perpendicularity

Perpendicularity in the alignment of a vertical-shaft unit refers to the relation of the thrust runner to the shaft or guide bearing journals (figure 11). If the bearing surface of the thrust runner is not perpendicular to the shaft, the shaft will scribe a cone shape as it rotates. Figure 12 illustrates this. The diameter of this cone measured at any elevation is referred to as the static runout at that point. The perpendicularity of the thrust runner to the guide bearing journals is measured indirectly by measuring the diameter of the static runout, usually at the turbine guide bearing journal.

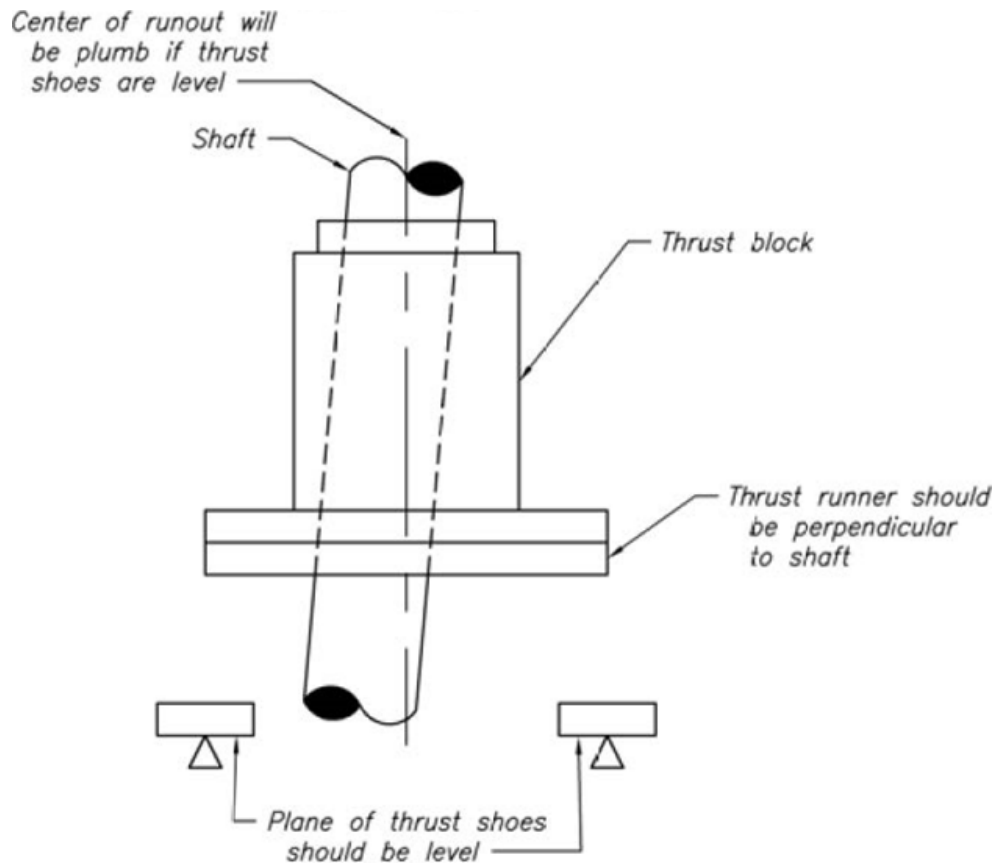

Figure 11.—Thrust bearing perpendicularity and level.

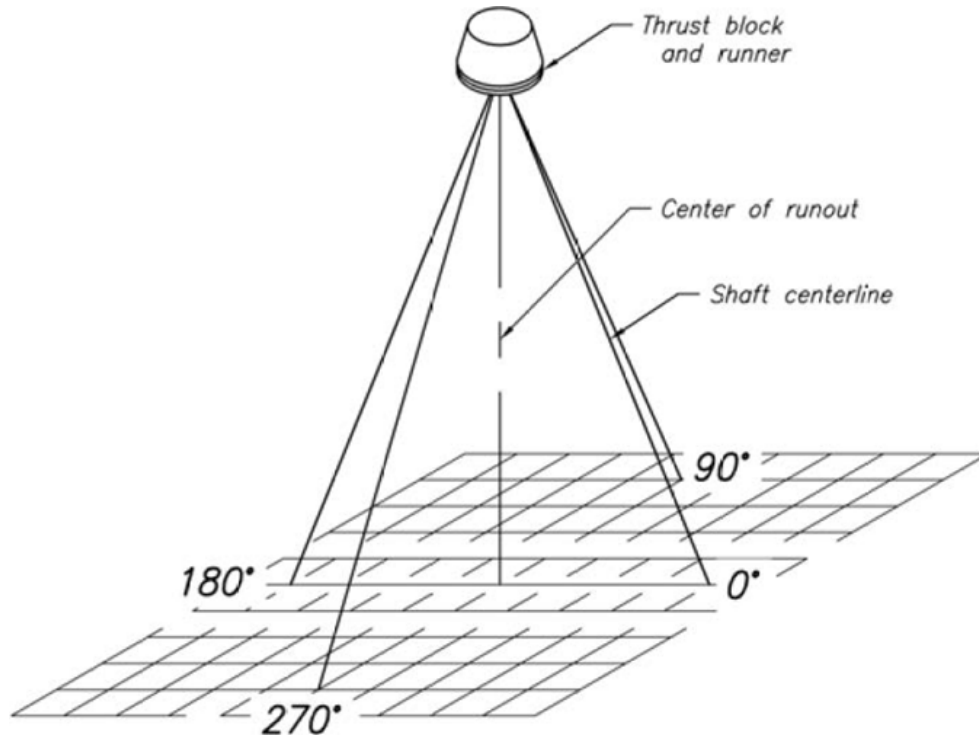

Figure 12.—Static runout.

## 2.2.5 Plumb

A line or plane is considered plumb when it is exactly vertical. While the final position of the shaft or the centerline of the unit may or may not be plumb, plumb is a reference for all measurements. Plumb wires, vertical laser systems, and precision levels all can be used to provide measurements that reference plumb. The plumb measurements are used to determine the position of the shaft and the center of runout. Based on the data from the plumb measurements, calculations can identify the adjustments to the plane of the thrust shoes needed to move the center of runout in line with the centerline of the stationary components. If the centerline of the stationary components is plumb, then the center of runout will be plumb and the thrust shoes will be level. Referring again to figure 12, we can see that if the shaft is plumb in the 0-degree position, it will be out of plumb by the runout diameter once the shaft is rotated 180 degrees. If the center of runout is plumb, the shaft will be out of plumb by half the runout diameter in any rotational position. As long as the runout diameter is within tolerance, this will be acceptable. By making the center of the runout plumb, the thrust shoes are made level (figure 11).

Concentricity is more important than plumb. While it is always desirable for the unit to be concentric and plumb, sometimes making a unit plumb is not practical. Settlement of the powerplant's foundation over time can make the unit's centerline out of plumb. Units that are out of plumb by more than 0.1 inch are not uncommon. Usually, the entire plant settles uniformly so that the unit's stationary components are still concentric, just out of plumb, so there are typically no operational issues.

Before plumbing a unit that has moved due to settlement, several items should be considered. Plumbing the shaft without moving the center of the turbine or stator can leave the generator air gap out of tolerance. As the turbine seal rings are the point of tightest clearance, the turbine will have to be centered in its seal rings. Plumbing the unit at this point will put the rotor out of center in the stator by the amount the unit has settled. If the air gap is out of tolerance, it will lead to higher loading on the guide bearings.

If the unit has moved considerably, the seal rings and turbine bearings may no longer be concentric with one another if the unit is made plumb. It will be necessary to choose a best center for the seal rings and make the necessary calculations to ensure that there will still be clearance in both rings.

The turbine bearing is usually a long sleeve bearing with tight clearances. If the shaft is made plumb in a bearing that is at an angle, the shaft may bind in the bearing. Calculations should be made to ensure there is clearance at all points top to bottom or the bearing housing is to be leveled.

The installation of a new turbine can provide an opportunity to restore the unit to plumb. Seal rings can be installed with extra material to allow them to be bored in place, concentric and plumb with the generator stator. If this is being considered, plumb readings should be taken of the unit to determine if this is practical. There may be limitations in the turbine design as to how far the center can be moved and it is important to know how far it would have to be moved to make it concentric with the generator. Depending on how far out-of-level the headcover is due to settlement, it may be necessary to machine the headcover flange on the scroll case. New wicket gate bushings will have to be installed and line bored in place to match the new headcover setting. It may also be necessary to re-level the servomotors to match the headcover setting.

The same considerations should be made when rewinding the generator. If the stator iron is replaced, the bore of the stator can usually be moved to be plumb with the turbine. If the turbine components are still out of plumb, there can be issues with the turbine bearing.

Any time a unit is disassembled, the relative positions of the centers of the stator, the turbine bearing, and the seal rings should be evaluated. If plumbing the shaft in the turbine will make the air gap out-of-tolerance or create binding in the turbine bearing, the unit should be aligned, out-of-plumb, centered in the stator and the turbine.

## 2.2.6 Straightness

Straightness refers to absence of bends or offset in the shaft. Offset is the parallel misalignment between two shafts and occurs at the coupling between the generator and turbine shafts. Angular misalignment at the coupling is referred to as dogleg (figure 13). Usually, the individual generator or turbine shafts are assumed to be straight, and any angular misalignment is assumed to be in the coupling. In most cases this is true, but in some cases, the generator or turbine shaft is not straight. The shaft is considered straight when no point varies more than 0.003 inch from a

straight line joining the top and bottom reading points. Nothing is normally done to correct dogleg or offset unless it is large enough to significantly affect the static runout. If necessary, dogleg can be corrected by shimming the coupling. Offset is rarely large enough to cause a problem and usually can be corrected by re-machining the coupling flanges and re-boring the coupling bolt holes.

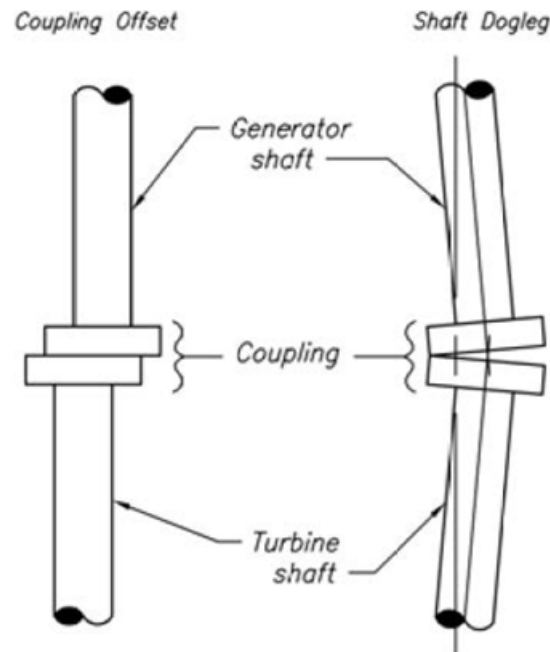

Figure 13.—Shaft offset and dogleg.

## 2.3 Required Equipment

The basic equipment for vertical-shaft alignment consists of:

- Dial indicators and bases (two per guide bearing).
- Feeler gauges for measuring bearing, seal ring, and other clearances.
- A taper gauge or other means of measuring the generator air gap.
- Inside micrometers for measuring the distance between the shaft and bearing brackets.
- Some means of measuring position of the shaft relative to plumb.

Shaft position readings can be taken using the traditional plumb wire system, a laser-based system, or a precision level.

### 2.3.1 Plumb Wires

Traditionally, plumb readings were most frequently obtained using stainless steel, nonmagnetic piano wires and an electric micrometer. Four wires are hung 90-degrees apart with a finned plumb bob (figure 14), which typically weighs around 20 to 30 pounds, attached to each wire and suspended in buckets filled with oil to dampen movement. The electric micrometer (figure 15) is used to measure the distance from the wires to the shaft. There are variations in design, but the basic concept is the same. The electric micrometer is made up of an inside micrometer head, headphones, battery, shaft, and “Y-shaped” end. A simple circuit is completed when the micrometer head touches the plumb wire, which causes static in the headphones. Banding material is installed on the shaft to provide a place to rest the “Y” end of the micrometer and to ensure repeatability in the readings.



Figure 14.—Plumb wire setup.



Figure 15.—Electric micrometer.



Since the wire is perfectly plumb, the plumb of the shaft is determined by comparing the difference in readings at different elevations, with two elevation readings initially taken above the shaft coupling and two below the coupling, which provides measurement of dogleg and offset (this procedure is covered in much more detail in section 2.4.3.1). If the turbine and generator shafts were exactly the same diameter and neither shaft had any taper in shaft diameter, only two wires, 90 degrees apart would be required to obtain plumb data. Since the turbine and generator shaft are rarely exactly the same diameter, and slight tapers in the shaft are common, four plumb wires are normally used, 90 degrees apart. The difference in the north-south and the east-west readings are used in determining the shaft plumb. The four wires also provide the added benefit of a check for accuracy of readings. Figure 16 is an example of the form used to record the readings.

Where plumb wires are being used, care should be taken to ensure there are no kinks in the wires. With the weights installed, the entire length of each wire should be checked by feel for any bends or kinks. If any kink can be felt, the wire should be replaced. While the wires don't have to be an equal distance from the shaft, they should be within 1/2 inch so that they are within the range of the micrometer head. The brackets for the oil buckets should be sturdy and secure to prevent spilling oil while taking readings. The weights should be heavy enough to keep the wires very taut but not so heavy as to consistently break the plumb wires. The weights, when suspended in the oil, should be completely submerged, but they should not touch the bottom or the sides of the bucket. The steel banding material placed around the shaft at the reading elevations should be level, and the distance from the coupling should be rechecked occasionally during the alignment process to make sure it corresponds with the dimensions used for plotting.

Plumb wires provide a reliable reference to plumb and can provide an accurate measurement of shaft position. The components required to take plumb wire readings are easy to obtain and are relatively inexpensive. Once the wires are set up, it is a fairly simple process to obtain the required readings.

There are disadvantages as well in using plumb wires. Setting up the wires can be very time consuming. Getting the wires uncoiled and suspended without any kinks or bends can be difficult. The wires and buckets may get in the way. Broken wires and dumped buckets are very common during an alignment with plumb wires. The biggest downside to using plumb wires is their susceptibility to vibration caused by the operation of other units. Many times, it may be necessary to shut down adjacent units in order to reduce the vibration enough to obtain accurate readings.

FIST Volume 2-1  
Alignment of Rotating Machinery

Unit alignment worksheet (plumb wires or laser systems)

Powerplant: FIST 2-1		Unit: 1			Date:				
Notes:									
		Column 1  Actual Readings	Column 2  Mathematical amount to be added to Col. 1 to theoretically move all wires an equal distance from center of shaft	Column 3  Total Column 1 plus Column 2	Column 4  Difference N&S E&W	Column 5  Half Column 4 (Out of plumb between top and bottom reading)	Column 6  Direction bottom of shaft is out of plumb. (Direction of smaller number in Column 3)	Column 7  Total N+S and E+W from Column 3	Column 8  Out of roundness or inaccuracy of readings (N+S) – (E+W). Should be less than 0.002
First Reading Elevation	North	0.3445	0.0000	0.3445	0.0000				
	South	0.1505	0.1940	0.3445					
	East	0.1710	0.1735	0.3445	0.0000				
	West	0.2985	0.0460	0.3445					
Second Reading Elevation	North	0.3425	0.0000	0.3425	0.0035	0.00175	N	0.6885	0.0000
	South	0.1520	0.1940	0.3460	0.0005	0.00025	W	0.6885	
	East	0.1710	0.1735	0.3445					
	West	0.2980	0.0460	0.3440					
Third Reading Elevation	North	0.3495	0.0000	0.3495	0.0080	0.0040	N	0.7070	0.0010
	South	0.1635	0.1940	0.3575	0.0010	0.0005	W	0.7060	
	East	0.1800	0.1735	0.3535					
	West	0.3065	0.0460	0.3525					
Fourth Reading Elevation	North	0.3470	0.0000	0.3470	0.0120	0.0060	N	0.7060	0.0005
	South	0.1650	0.1940	0.3590	0.0015	0.00075	W	0.7065	
	East	0.1805	0.1735	0.3540					
	West	0.3065	0.0460	0.3525					

(FIST 007) 08/02/2016  
NEW RELEASE

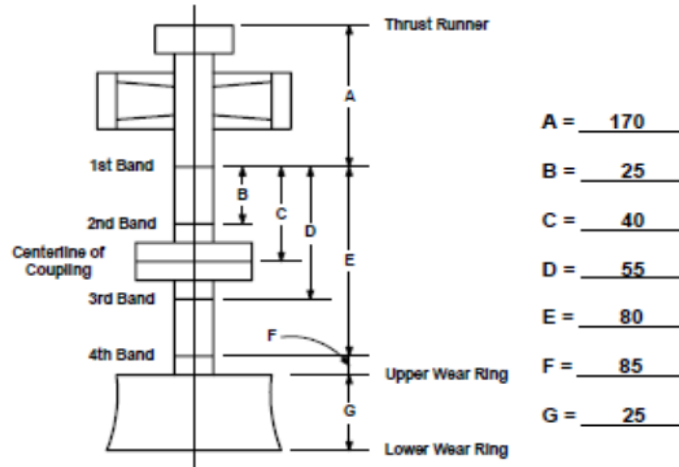

Figure 16.—Example of unit alignment worksheet (wires or laser system).

### 2.3.2 Laser Systems

Typically, most laser alignment systems for vertical shafts use the same principles as the plumb wire systems. A plumb laser beam takes the place of the wire (figure 17). A photoelectric target takes the place of the electric micrometer and measures the distance from the shaft to the laser beam (figure 18). Depending on the system, the laser may be mounted to a base which, in turn, is mounted to the shaft, or it may be mounted directly to the headcover. The laser is equipped with a coarse and fine adjustments and with a precision bubble level so it can be adjusted to plumb. The best practice is to move the laser to each of the four directions and level it at each location.



Figure 17.—Laser system.



Figure 18.—Target for laser system.

In comparison to plumb wires, laser systems are generally faster to set up and provide results that are just as accurate. Some laser systems have an averaging function in the device that records the reading, which helps mitigate the effects of vibration. It is typically not necessary to shut down adjacent units when using systems equipped with the averaging function. The main disadvantage of laser systems is their cost. Because they are built with high precision, the cost may be prohibitive.

### 2.3.3 Precision Levels

Precision electronic levels can be used to obtain an acceptable alignment of most vertical-shaft units. The level is attached to the shaft, and the shaft is rotated in 90-degree increments (figures 19 and 20). The plumb of the center of runout is determined by taking the difference between diametrically opposed readings and dividing by two. The straightness and position of the shaft can be determined by dial indicator readings at each guide bearing elevation.



Figure 19.—Precision level with magnetic base.



Figure 20.—Precision level attached to shaft with strap.

In order to meet the tolerances for vertical-shaft unit alignment, the level must be very precise. It should have a minimum resolution of 0.001 mils/inch or 0.2 arc seconds. This means that the level must be able to measure down to 0.000001 inch per inch of shaft length. The specifications may refer to measurements as micrometers per meter, which means 0.000001 meter per meter of shaft length. Typical calculations in the United States use mils/inch, but most levels are manufactured using the metric system, so the readings need to be converted. The level must have a right-angle base to allow it to be used in the vertical position.

The levels have the advantage of providing accurate readings much faster than is possible with tight wires or laser systems while meeting allowable tolerances. The main disadvantage of precision levels is that they don't provide a representation of the shaft centerline, only the plumb of the center of runout. The shaft centerline can be determined by taking dial indicator readings at each bearing elevation. A precision level can also be difficult to use with a self-equalizing

bearing, as the thrust bearing plane is not fixed. This can be worked around by building bearing jacking devices to hold the shaft in place while it is being rotated. Precision levels have become the most commonly used tool for alignment of hydroelectric and large pumps units at Reclamation facilities.

## 2.4 Basic Measurements

The type of equipment being used will determine the exact procedure, but generally when one performs a shaft alignment, the position of the shaft and relative positions of the stationary components need to be determined in order to make any adjustments. Also, the straightness of the shafts and the perpendicularity of the thrust runner to the shaft have to be addressed. With that basic information, the unit can be aligned within tolerance.

### 2.4.1 Preliminary Checks for All Units

1. Pre-shutdown readings. Operational readings taken prior to shutdown for an overhaul can prove useful for determining the condition of some of the equipment and provide a baseline for comparison when the unit is restarted. High vibration levels may indicate misalignment, unbalance, damaged bearings, or possibly just an inherent characteristic of a particular unit. Temperature plots of bearing heat runs from startup are useful not only for comparing a final operating temperature but also the rate of temperature rise after the unit overhaul is complete. Testing the bearing insulation on the thrust bearing and upper guide bearing on underhung units can save time in the long run. The insulation can deteriorate over time and the time to repair or replace it is during the overhaul. Some operational readings that should be recorded prior to the shutdown are:
  - a. Vibration readings at each guide bearing from startup to full load.
  - b. Temperature plots of guide bearings during a normal startup.
  - c. Normal operating temperatures of all bearing metal and oil.
  - d. Cooling water flow, if available.
  - e. Thrust and upper guide bearing insulation, per FIST 3-11.
2. As soon as the unit is taken apart, inspect bearings and bearing components. Check the bearings for wiping and the bond of the Babbitt to its shell. Re-Babbitt them if necessary or prepare spare bearings for use. Inspect the screw and pivot point of adjustable shoe thrust bearings and segmented shoe guide bearings. If there is any sign of wear of the pivot point, the pivot should be re-machined and possibly re-hardened. The threads on the adjustment screws should be cleaned up. Trying to make precision adjustments on components with damaged threads can be difficult. Restoring the bearing components to like-new condition will make the alignment process go more smoothly.
3. When the unit is taken apart, check the thrust block bore and shaft interface for signs of fretting. Fretting is a sign of relative movement between the two components and

indicates a loose fit. The bore of the thrust block may need to be built up and re-bored. Look for any shims either between the runner and block or on the shaft ledge on clamp bar thrust blocks. Check for fretting on the interface between the thrust runner and block. If pre-teardown readings indicated that the runner is not perpendicular to the shaft or if there are shims or fretting on either the bore or the runner, consider sending the thrust block to a machine shop for measuring and re-machining. This is a high-precision operation, so the machine shop should be chosen carefully.

4. Check for “soft foot” conditions on any of the bridge legs. A “soft foot” condition is similar to a short leg on a four-legged table; if left uncorrected, it can cause distortion of the bridge. Check for a “soft foot” by first checking that all bridge leg bolts are securely tightened. With a dial indicator, check the rise of each leg as its mounting bolts are loosened. Retighten the mounting bolts after the rise is recorded, so that only one leg is loose at a time. If one leg rises more than the other legs, it is a “soft foot,” and shims should be placed under that leg to correct the condition. For example, if one leg of a six-leg bridge rises 0.025 inch while the other five only rise 0.015 inch, a 0.010 inch shim should be added to the “soft foot.” There may be more than one “soft foot.” Shims should be added accordingly so that the rise of each leg is nearly the same. The existence of a soft foot is more likely to create problems with units that have spring-loaded bearings than with those having other bearing types, as any distortion of the bridge can make it difficult to predict the effect of shims.
5. Allow the thrust block to cool overnight after installation. The thrust block should be at ambient temperature before any readings are taken.
6. Establish direction convention for readings so that all readings agree. Directions don't have to match actual compass directions as long as all readings are consistent and everyone involved with the alignment understands the convention used. For example, it is common to refer to the readings as upstream, downstream, *i*, and *ii*, where *i* is the left-hand side when facing downstream. Note: For consistency, this document uses the north-south, east-west convention for directional references.
7. Remove packing and guide bearings. Install four jacking bolts at the upper guide bearing elevation or, if the guide bearing is a segmented shoe type, install four guide bearing shoes to hold the shaft in place when rotating and to allow lateral adjustment at the thrust bearing. If jacking bolts are fabricated, they should be faced with bronze or made with roller bearings to prevent damage to the shaft. Four jacking bolts installed at the turbine guide bearing may also be useful.
8. Install dial indicators at upper guide, lower guide, and turbine guide bearing elevations. Two indicators, 90 degrees apart, should be installed at each elevation. To prevent errors in readings, ensure that the dial indicators are in good condition and do not stick prior to installation. If available, four indicators for each elevation can be useful in providing a check for errors. Four indicators are especially useful at the upper guide bearing when pushing the shaft laterally, as there will be an indicator at each jack bolt location.

9. Ensure that the thrust bearing high-pressure oil lift system is operational. In some cases it may be necessary to remove the oil pot to gain access to the bearings for adjustment during the alignment process. If this is the case, it will be necessary to provide a temporary oil source for the pump and some type of containment system for oil coming out of the bearing.
  
10. One of the most important things to check before any readings are taken is whether the shaft is free. A free shaft is essential for the readings to have any value whatsoever. The shaft is free when the thrust runner is sitting on the thrust bearing and the rotating components are not in contact with any stationary component. This means that all guide bearings must be removed or backed off, packing or mechanical seals must be removed, and the turbine should be close to center in the seal rings. The shaft of a vertical-shaft unit, when free, should be able to swing like a pendulum. A free shaft in most cases will move easily a minimum of 0.005 inch in any direction with very light hand pressure. There are exceptions. In umbrella units, because of the location of the thrust bearing, some type of lever may be needed between the shaft and the bearing housing to get the shaft to swing. Regardless of whether the shaft moves by hand pressure or requires a lever, it is critical that it can swing in all directions and always return to the same position. If the shaft swings freely in one direction but seems damped in the other or if the swing isn't smooth, there may still be contact somewhere in the unit. If there is any doubt that the shaft is free, it should be moved at the thrust bearing away from the apparent point of contact a few mils at a time until it is totally free. If a shaft doesn't return to its original position after it is pushed, there is probably something still touching it. A free shaft is critical for several reasons. First of all, plumb readings are taken to determine the natural position of the shaft and thrust shoes. If the shaft is touching anything, that will prevent it from moving to its neutral position, and, hence, the readings will not reflect the true plumb of the unit. The apparent straightness of the shaft can also be affected by the shaft contacting a stationary component. If the shaft is put in a bind, it can actually be bent to the point that a plot of plumb data will show a dogleg that may not exist. It is important to check for a free shaft before each reading because a slight shift on the thrust block can cause contact somewhere on the shaft. It should be noted that a unit equipped with a self-equalizing bearing will not swing like a pendulum. Since the plane of the thrust bearing will change as shaft is moved, the shaft will tend to stay wherever it is pushed. In the case of a self-equalizing bearing, it is important to push the shaft back and forth to ensure that there is clearance in all directions.
  
11. Check the height of the turbine in the scroll case with the shaft hanging from the thrust block. The entrance opening on a Francis turbine should be centered between the wicket gate facing plates. The turbine drawing may have tolerances for the turbine's location. This is important because, if the runner is too high or too low, a lip at the runner-facing plate interface could cause cavitation damage. It is important to make this adjustment before the alignment begins. Otherwise, the entire alignment may have to be redone, as it is nearly impossible to avoid changing the alignment to some extent when adjusting the height. The height of the runner is adjusted by either shimming the thrust bearing bridge



(upper bridge on underhung units, lower bridge on umbrella units) or, if the unit has adjustable shoe bearing, by adjusting the height of the bearing shoes.

12. Determine the 0-degree shaft position and clearly mark this position. Typically, the shaft is rotated so that the Number 1 rotor pole is upstream. Following this convention provides a reference for the data for any future alignments on the unit.
13. Develop a system so that data collection and entry into forms and spreadsheets is done correctly. A 90-degree rotation from north may change the direction to east or west. Make sure the reading is entered correctly. Mark the shaft, mark the indicators, mark the bearing housings, etc. Do whatever it takes to ensure readings are recorded correctly.

## 2.4.2 Static Runout

Due to non-perpendicularity between the thrust runner and the shaft, as the shaft rotates with the guide bearings and packing removed, the shaft centerline will scribe a cone shape, as shown on figure 12. This is referred to as static runout. The tolerance for perpendicularity between the thrust runner and the shaft is 0.002 inches across the thrust runner diameter. This is difficult to measure directly but the effect of non-perpendicularity can be determined by measuring the static runout diameter at a known distance from the thrust runner. The tolerance for static runout is calculated by the following formula:

$$R \leq \frac{0.002 \times L}{D}$$

Where:

R = maximum allowable runout diameter  
L = length of shaft, thrust bearing to point of runout measurement  
D = diameter of thrust bearing

Exceeding the tolerance can lead to higher loading and higher vibration levels at the guide bearings. However, since the guide bearings tend to constrain the shaft and limit the dynamic runout, much of the movement may be taken up by more movement of the thrust shoes. This can lead to excessive wear of the pivot points on adjustable shoes and self-equalizing bearings and to broken springs on spring-supported bearings. A bent shaft or dogleg and offset at the coupling can also contribute to excessive static runout. The source of the runout should be determined as part of the alignment process.

To measure the static runout diameter, it is necessary to rotate the shaft, which requires operating the high-pressure oil lift system. In order to do so, a temporary source of oil may be needed because, in some cases, the oil tub has to be removed during the alignment. If this is the case, some temporary method of routing the oil from the bearings to the drain is required as well. If a high-pressure oil lift system is not installed, it will be necessary to jack up the unit to get oil

Alignment of Rotating Machinery

under the shoes prior to each rotation. In this case, the rotor is jacked up, and then, immediately after the jacks are released, the rotor is rotated.

If plumb wires or a laser system is used, the runout diameter can be determined from multiple plumb readings. In this method, the shaft is rotated to the 0-, 90-, 180-, and 270-degree positions. Readings are usually taken only at two elevations to speed up the process because the straightness of the shaft should already be verified. From the plumb readings, it is possible to determine the diameter of runout at the turbine bearing and the location of the center of runout with respect to plumb. Figures 21 and 22 are examples of the forms used to record the data and perform the calculations. This is a very time-consuming procedure and is not recommended.

**Unit runout worksheet (part 1 of 2, plumb wires or laser system)**

Powerplant: FIST 2-1			Unit: 1				Date:			
Notes:										
			Column 1	Column 2	Column 3	Column 4	Column 5	Column 6	Column 7	Column 8
			Actual Readings	Mathematical amount to be added to Col. 1 to theoretically move all wires an equal distance from center of shaft	Total Column 1 plus Column 2	Difference N&S E&W	Half Column 4 (Out of Plumb between top and bottom reading)	Direction bottom of shaft is out of plumb. (Direction of smaller number in Column 3)	Total N+S and E+W from Column 3	Out of Roundness or inaccuracy of readings (N+S)-(E+W) Should be less than 0.002
0° Position	First Reading Elevation	North	0.3455	0.0000	0.3445	0.0000				
		South	0.1505	0.1940	0.3445					
		East	0.1710	0.1735	0.3445	0.0000				
		West	0.2985	0.0460	0.3445					
	Fourth Reading Elevation	North	0.3470	0.0000	0.3470	0.0120	0.0060	N	0.7060	0.0005
		South	0.1650	0.1940	0.3590					
		East	0.1805	0.1735	0.3450	0.0015	0.00075	W	0.7065	
		West	0.3065	0.0460	0.3525					
90° Position	First Reading Elevation	North	0.3000	0.0000	0.3000	0.0000				
		South	0.1800	0.1200	0.3000					
		East	0.1420	0.1580	0.3000	0.0000				
		West	0.2370	0.0630	0.3000					
	Fourth Reading Elevation	North	0.3460	0.0000	0.3460	0.0145	0.00725	N	0.7065	0.0000
		South	0.2405	0.1200	0.3605					
		East	0.1910	0.1580	0.3490	0.0085	0.00425	E	0.7065	
		West	0.2945	0.0630	0.3575					
180° Position	First Reading Elevation	North	0.3315	0.0000	0.3315	0.0000				
		South	0.1485	0.1830	0.3315					
		East	0.1620	0.1695	0.3315	0.0000				
		West	0.2175	0.1140	0.3315					
	Fourth Reading Elevation	North	0.3510	0.0000	0.3510	0.0040	0.0020	N	0.7060	0.0005
		South	0.1720	0.1830	0.3350					
		East	0.1785	0.1695	0.3480	0.0105	0.00525	E	0.7065	
		West	0.2445	0.1140	0.3585					
270° Position	First Reading Elevation	North	0.3650	0.0000	0.3650	0.0000				
		South	0.1120	0.2530	0.3650					
		East	0.0955	0.2695	0.3650	0.0000				
		West	0.2845	0.0805	0.3650					
	Fourth Reading Elevation	North	0.3520	0.0000	0.3520	0.0020	0.0010	N	0.7060	0.0005
		South	0.1010	0.2530	0.3540					
		East	0.0835	0.2695	0.3530	0.0005	0.00025	E	0.7065	
		West	0.2845	0.0805	0.3650					

(FIST 007) 08/02/2016

NEW RELEASE

(Minor revisions approved 09/16/2016, 05/29/2024)

FIST Volume 2-1  
 Alignment of Rotating Machinery

		West	0.2730	0.0805	0.3535				
--	--	------	--------	--------	--------	--	--	--	--

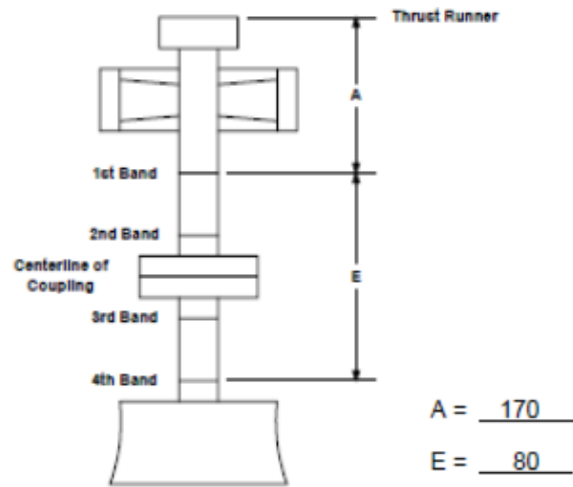

Figure 21.—(Part 2 of 2) Runout worksheet  
 (wire or laser system).

Another method for measuring static runout requires installing dial indicators at the guide bearing elevations. If plumb wires or a laser system is used, dial indicators are only required at the upper guide and turbine guide bearings. If the precision level is used, indicators should be placed at all three guide bearings. The extra set of indicators is used to determine shaft straightness. Two indicators are located at each elevation to indicate movement in the north-south and east-west axes. The indicators are zeroed with the shaft in the 0-degree position. The shaft is then rotated 90 degrees. If the shaft is not totally free after rotating, move it laterally at the thrust bearing until it is free. The indicators are read once the shaft is free. These steps are repeated for the 180-, 270-, and 360-degree positions. The corrected data for the 360-degree position should be close to zero. An example of a form for recording the data using this method is shown on figure 23. It is important that the dial indicators not be moved or adjusted after they are zeroed at the 0-degree position. The top reading is subtracted from the readings at the other bearings to correct for any lateral movement at the thrust bearing and to provide the actual runout at the other bearings.

The plot of the runout should create a circular pattern, i.e., lines drawn between the 0- and 180-degree points and between the 90- and 270-degree points should be equal in length and perpendicular to each other. The static runout diameter is determined by the calculating the distances between the 0- and 180-degree points and between the 90- and 270-degree points. As a check of accuracy, these two measured diameters should be within 2 to 3 mils of each other. The corrected reading at 360 degrees should be less than 2 mils.

Powerplant:		Unit:		Date:	
Notes:					
		Column A	Column B	Column C	Column D
		Multiplier to determine total out of plumb (A+E)/E	Values of Column 5 of runout worksheet	Total out of plumb (Column A × Column B)	Direction Shaft is out of Plumb (Column 6)
0° Position	North-South	3.125	0.0060	0.0187	N
	East-West	3.125	0.00075	0.0023	W
90° Position	North-South	3.125	0.00725	0.0227	N
	East-West	3.125	0.00425	0.0133	E
180° Position	North-South	3.125	0.0020	0.0063	N
	East-West	3.125	0.00525	0.0164	E
270° Position	North-South	3.125	0.0010	0.0031	N
	East-West	3.125	0.00025	0.0008	E

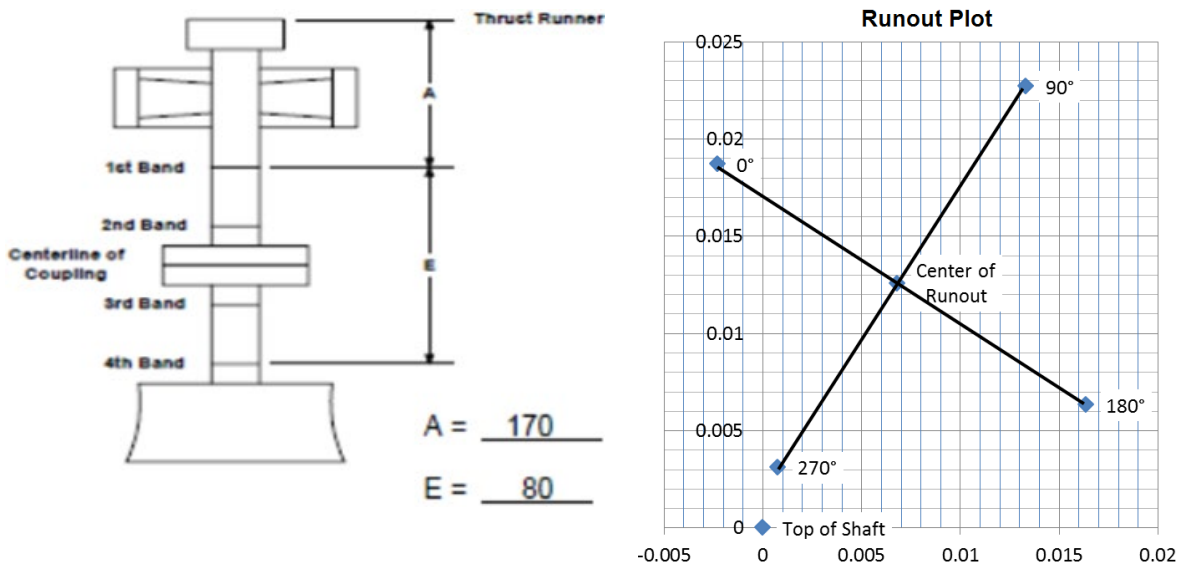

Figure 22.—Runout data and plot (wire or laser system).

The tolerance for non-perpendicularity is the same for self-equalizing bearings as it is for other designs. The amount by which the thrust runner is out of perpendicular to the shaft should be 0.002 inch or less across the diameter of the thrust runner. Maintaining this tolerance will limit

**FIST Volume 2-1**  
**Alignment of Rotating Machinery**

wear to the pivot points on the shoes and leveling plates. Since the thrust bearing shoes move with the runner, it isn't possible to check the perpendicularity using the static runout method. It is necessary to hold the shaft steady and measure the movement of the thrust runner. To do this, set up indicators to measure the up and down movement at the outer edge of the thrust runner, and other indicators at the guide bearings to measure lateral movement there. Also fabricate some means of holding the shaft. Some type of bracket with roller bearings that can be tightened snug against the shaft works best. Rotate the shaft in 90-degree increments as with the static runout measurement. If there is any lateral movement at the guide bearings, move the shaft so that indicators at the bearings show zero. The indicator on the thrust runner can be read once the other indicators are at zero. The maximum reading minus the minimum reading should not exceed 0.002 inch.

**Runout worksheet using dial indicators at two elevations**

Plant: FIST 2-1	Unit: 1				Date:					
Notes:										
	0°		90°		180°		270°		360°	
	N	E	N	E	N	E	N	E	N	E
Upper Guide	0	0	0	1	1	-1	1	0	1	0
Turbine Guide	0	0	4	16.5	-11.5	17.5	-14.5	2.5	1	0
Corrected Turbine - Upper	0	0	4	15.5	-12.5	18.5	-15.5	25	0	0

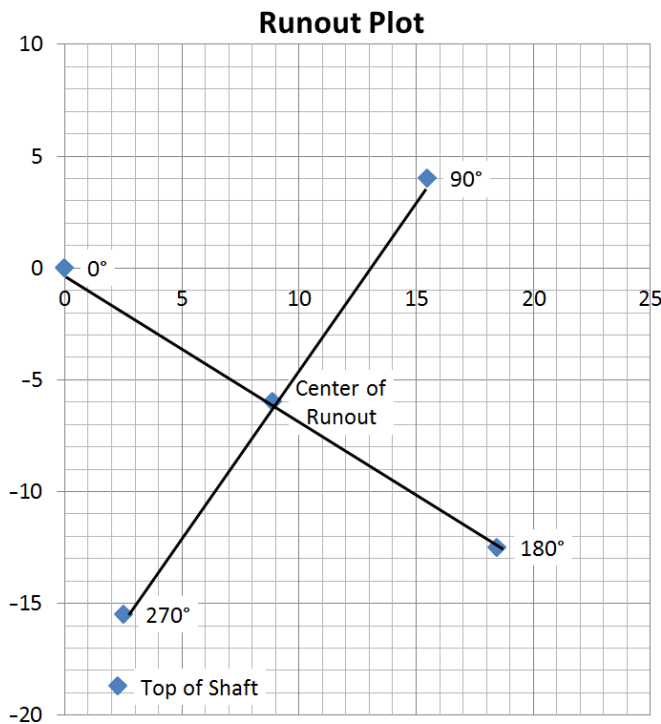

Figure 23.—Runout using dial indicators at two elevations.

(FIST 007) 08/02/2016  
 NEW RELEASE

### 2.4.3 Plumb Readings

Plumb is the reference for all readings on vertical-shaft alignments. If plumb wires or a laser system is used, the relative plumb of the shaft is measured. If a precision level is used, the plumb of the center of runout is measured. All other measurements such as runout readings and clearance readings are plotted relative to the plumb readings.

Because of the non-perpendicularity of the thrust runner to the shaft, when a unit is aligned, the center of static runout is plumbed, not the shaft. Doing this makes the thrust shoes level, and the shaft then will be out of plumb by the same amount in any position. When plumb wires or a laser system is used, the plumb of the center of runout has to be determined by plotting data from dial indicator readings against the plumb readings or by multiple plumb readings. When a precision level is used the plumb of the center of runout is measured directly but the position of the shaft then must be determined for setting guide bearings. This can be done by plotting the information from the dial indicators against the plumb data from the level. In the end, the plots of the data, shaft plumb and runout, will be the same regardless of what equipment is used; the procedure to get to that point will be different.

#### 2.4.3.1 Plumb Wire or Laser System

With the plumb wire or laser system, the position of the shaft relative to plumb is determined by measuring the distance from the shaft to a plumb wire or laser in four positions. If wires are used, four wires are hung; if a laser is used, the laser is moved to each of the four positions. To determine the straightness at the shaft coupling, typically readings are taken at two elevations on each shaft. As most units have only a generator and a turbine shaft, only four reading elevations are required, but on units that have an intermediate shaft, six reading elevations are required. To ensure that all readings are taken at exactly the same elevation and to provide a rest for one end of the electric micrometer, banding material is usually attached to the shaft at the reading elevations. The bands on each shaft for the readings should be located as far apart as possible to improve the accuracy of the plot. The top reading band for the generator shaft should be as high as possible, and the lower one just above the coupling flange. On the turbine shaft, the lower band should be as low as possible, with the top band just below the coupling flange. As the target for laser systems is attached to the shaft with a magnetic base, the bands aren't absolutely necessary, but can be helpful ensuring that the readings are taken at exactly the same elevation at all four positions. Ladders or scaffolding may be required to provide access to the upper band. If a ladder is used, it is not rested against the shaft.

Taking readings at only two elevations on each shaft embraces the assumption that the individual shafts are straight and any bends will be at the coupling. If there is any reason to believe that a bend exists in a shaft, more reading elevations should be used. If there is only a short section of the generator shaft accessible below the rotor, readings above the rotor may be required.

Shaft plumb readings allow a plot of shaft centerline to be drawn as on figure 24. This plot uses the data from figure 16. The plot of the shaft will provide information on straightness of the shaft. Once the shaft is plotted, the plumb of the center of runout and the relative position of

other components can be plotted as well. From the plot, plumb and concentricity of the stationary components can be determined.

### **2.4.3.2 Precision Level**

The setup for the precision level is very simple. The level is attached to the shaft. Some levels have magnetic bases to facilitate this, but if the base is not magnetic, the level may be held firmly to the shaft with a nylon strap (figures 19 and 20). Even with the magnetic base, using the nylon strap is a good idea. The level should be attached to line up with some known position on the unit such as the number one rotor pole. This will be the 0-degree position. Since the plumb is determined by the difference between two readings there is no reason to calibrate the level to true level.

Dial indicators should be placed at three elevations. The shaft straightness can be determined by comparing the runout at different elevations. If there are three guide bearings, the dial indicators should be set up on the bearing journals. If the unit has only two guide bearings, a third set of indicators should be installed to measure runout on the shaft somewhere between the two bearings. This may require fabricating some brackets to support the dial indicators. At least two indicators, 90 degrees apart, should be used at each elevation.

The dial indicators should be zeroed and the level's readout recorded at the 0-degree position. The rotor is then rotated 90 degrees and the shaft checked to verify that it is free. If the shaft is not free, move it laterally at the thrust bearing until it is free. Record the readings from the dial indicators and level only after the shaft is free. The indicators should not be re-zeroed, as they are recording the lateral movement of the shaft. The lateral movement at the thrust bearing will be subtracted out in the calculations. In reading the dial indicators and levels, give careful attention to the sign of the readings. A positive reading on the level indicates the bottom of the shaft is leaning toward the side with the level. This step is repeated until the rotor is rotated to its starting point.

Some available procedures call for moving the level and leaving the shaft in one position. The idea in these cases is to provide the plumb of the shaft rather than the plumb of the center of runout. While this can provide a general idea of the plumb of the shaft, it is not typically acceptable. The sensitivity of the level combined with slight imperfections on the surface of the shaft make it very difficult to obtain repeatable readings. Placing the level on the shaft, removing it, and replacing it to the same point will likely provide very different readings. While the difference might seem small, it may be too great to allow these readings to be used in determining shoe loading or bridge shims. If the point of the readings is only to determine the general out-of-plumb of a unit, then this type of procedure may be acceptable.



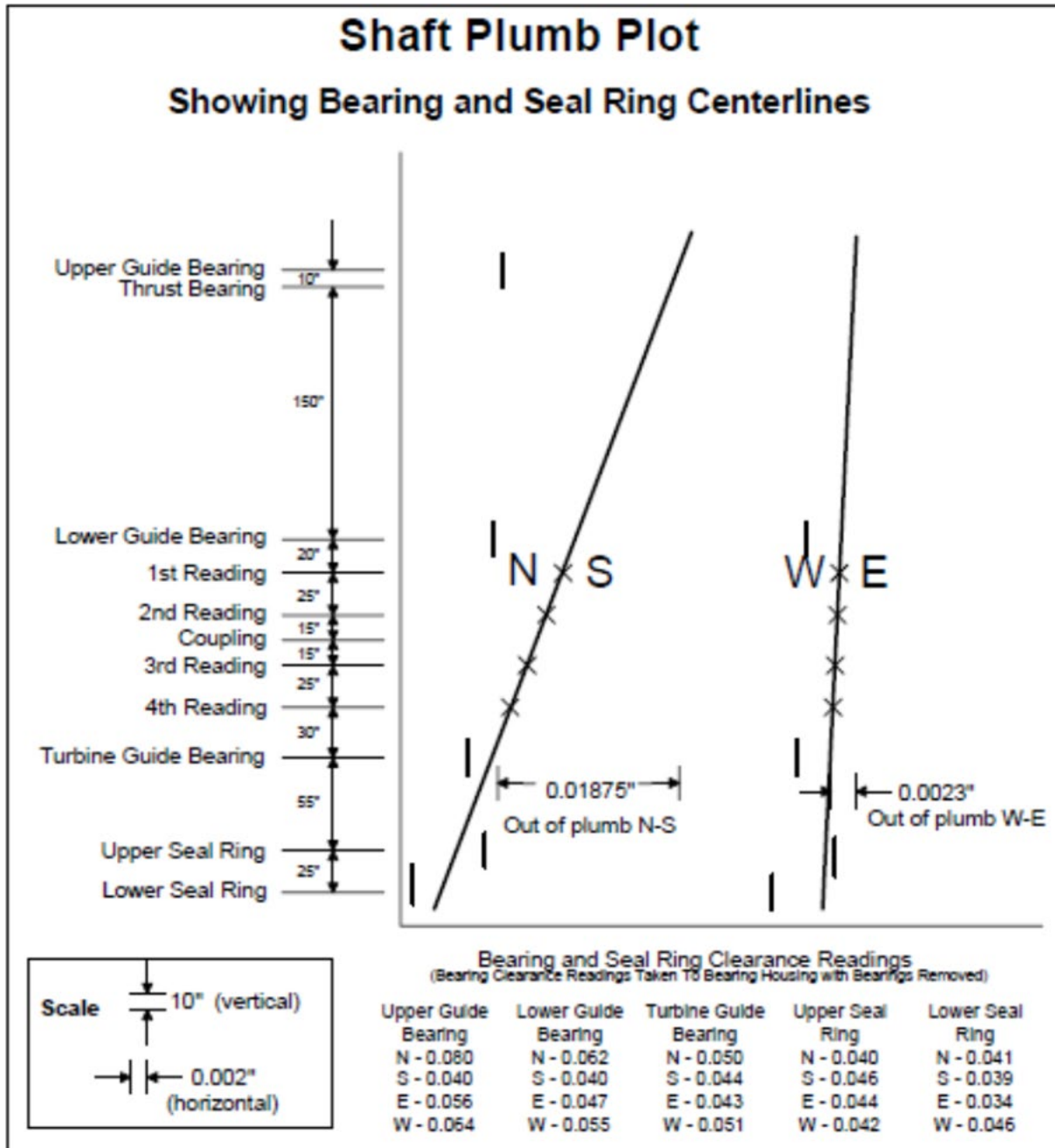

Figure 24.—Plot of shaft centerline.

#### 2.4.4 Clearance and Concentricity Readings

If the unit is completely disassembled, the concentricity of the stationary components can be checked by temporarily installing the upper and lower bridges and the head cover and hanging a single plumb wire through the unit. An electric micrometer is used to measure the distance from the wire to the stationary components. Laser systems are also available to measure the positions

of the stationary components. This procedure is particularly useful during major overhauls. If new stationary seal rings are being installed, this procedure provides a reference to allow the seal rings to be bored concentric to the stator. It also allows a more accurate profile of the stator to be determined. With the rotor installed, only the top and bottom of the stator can be measured. With the rotor removed and the single wire installed, readings can be taken at several elevations to get a true profile of the stator bore. The turbine bearing housing can also be centered to the seal rings at this time. On many units, once the wicket gate linkage is installed, moving the turbine bearing is difficult or impossible.

The single wire or laser system can also be used to center and re-dowel the upper and lower bridges concentric to the generator stator and the turbine seal rings. This is especially important on units that have sleeve-type generator guide bearings; on these units the bridges should be temporarily installed with the bearings in place and the bridges centered using the center of the bearing bores as the reference point. This ensures that the bearings will be centered even if they are not concentric to their fit in the bridges.

When the unit is assembled, the concentricity of the stationary components can be determined by taking clearance readings (i.e., bearing clearance, seal ring clearance, generator air gap, etc.) and plotting the centers against the plot of the shaft centerline (figure 24). The concentricity should be verified using this method regardless of whether it was previously checked with a single wire. Do not assume that everything is still concentric. Even doweled components can shift slightly.

The internal diameter of a sleeve-type guide bearing should be concentric with the outside fit of the bearing shell. Therefore, when the bearing is not installed, the bearing center can be determined by measuring with an inside micrometer from the fit on the bearing bracket or bridge to the journal. On turbine bearings that use a tapered fit, a jig, or some other means should be used to ensure that the readings are taken at the same point of the taper at all four measurement points.

When measurements are taken from the shaft to the bearing housing with an inside micrometer, it is not necessary to calibrate the micrometer because only the differences between readings and not absolute dimensions are of interest. The bearing clearances should always be verified after installation in case the bearing surface is not concentric to its fit.

## **2.5 Plotting the Data**

### **2.5.1 Plumb and Runout Data**

Plotting the data from the plumb and runout measurements will determine what adjustments are required to align the unit. Combining the plumb and runout data provides a picture of the position of the shaft and the perpendicularity of the thrust runner to the shaft. While the processes are very different, plumb wires, lasers, and precision levels ultimately provide the same information. The following describes how to manually plot the shaft centerline and center of runout on a plumb plot of the unit. Developing spreadsheets in Microsoft Excel® to do these

calculations and plots not only speeds up the process but lessens the chance of errors in calculations.

### **2.5.1.1 Plumb Wires or Laser Systems**

**Shaft plumb plots.** Plumb readings from either plumb wires or a laser system are used with the worksheet on figure 16. The actual readings are entered in Column 1. As mentioned above, the electric micrometer readings are not calibrated, so these readings mean nothing by themselves. The difference between readings is what is used to determine the plumb of the unit. Since the wires will not be the same distance from the shaft, an amount is added to each reading in Column 2 to mathematically make all four wires the same distance from the shaft at the first reading elevation. This will simplify subsequent calculations. The first elevation is considered the origin for the plot of the shaft. Some laser systems automatically zero the top reading but this form can still be used. The values in Column 2 are calculated by taking the largest value of Column 1 in the first reading elevation and subtracting each of the other three measurements. As the wires have been mathematically moved these distances at the first elevation, these values are to be carried through the rest of the reading elevations. Column 3 is the sum of Columns 1 and 2. If the values in Column 3 at the first elevation are all equal to the largest value in Column 1, the values in Column 2 are correct. Column 4 is the difference between north and south or between east and west. Column 5 is one-half of Column 4, which is the amount the shaft is out of plumb from the first elevation, the origin of the plot. Column 6 indicates the direction the shaft is out of plumb from the first reading. Columns 7 and 8 are used to calculate the accuracy of the readings. Column 7 is the sum of the north and south and east and west readings. As most shafts are usually round within 0.001 inch, any value in Column 8 of more than 0.002 inches is considered excessive and is probably due to an error in a measurement or in reading the micrometer.

To plot the plumb of the shaft centerline, the values in Column 5 and the directions in Column 6 are used. Two separate plots will be required, one for the north-south profile and one for the east-west profile. Usually, both plots are drawn on a single sheet of graph paper. To determine the vertical scale for the plot, the vertical distances in inches shown on the sketch on the bottom of figure 16 are used. The distances between the thrust bearing and coupling and the distances from the coupling to the seal rings are obtained from the manufacturer's drawings. After choosing a suitable scale on graph paper, mark on the vertical scale the elevation marks for the thrust bearing, the reading elevations, and the shaft coupling. To plot the centerline of the guide bearings, seal rings, and generator stator, their elevations will have to be added to the graph as well. Figure 24 is an example of a shaft plumb plot.

The horizontal axis will be the plumb of the shaft. The horizontal scale should be chosen based on the total out-of-plumb of the shaft. Usually, a scale of 0.001 inch per division will work, but if the shaft is considerably out-of-plumb, as is the case many times on the first reading after reassembly, a scale of 0.002 inch or more per division may be required.

Once an acceptable scale is laid out, draw two vertical lines on the graph. These lines represent zero, or perfect plumb, for the north-south and the east-west plots. Label north, south, east, and west on their respective sides of the lines. The point for the first reading elevation will be directly

## Alignment of Rotating Machinery

on the vertical line for both the north-south and east-west plots. The second, third, and fourth reading elevation points are all plotted the amount indicated in Column 5 away from the vertical line in the direction indicated in Column 6.

With all the points plotted, draw a line from the first elevation point to the second elevation point and extend the line to the shaft coupling elevation on both the north-south and the east-west plots. This line represents the generator shaft. Draw a line from the fourth to the third elevation points and extend it up to the coupling elevation. This line represents the turbine shaft. The horizontal distance between the lines at the coupling is the amount of offset. Any angle between the two lines indicates dogleg.

To determine the total effect of the dogleg and offset on the static runout, extend the generator shaft line down to the fourth elevation. The horizontal distance at the fourth reading elevation from the extended generator shaft line to the turbine shaft line, multiplied by two, is the total effect of dogleg and offset on the static runout at the fourth elevation. If the amount of dogleg will cause the static runout to exceed the maximum allowable runout as calculated in the next section, some correction will probably be required. If the dogleg and offset are acceptable, only the first and fourth elevation readings are required for subsequent readings.

If the generator and turbine shaft are straight, the total out-of-plumb can be determined by drawing a line from the first to the fourth elevation points and extending it upward to the thrust bearing elevation. From the point where this line intersects the thrust bearing elevation, draw a vertical line downward to the fourth reading elevation. The horizontal distance along the fourth reading elevation line from the originally plotted reading to the projected vertical line is the total out-of-plumb at that elevation.

If the dogleg is significant enough to require readings at all four elevations, the total out of plumb is determined by extending the generator shaft line upward to the thrust bearing elevation. Again, a vertical line is drawn downward from the point where this line crosses the thrust bearing elevation to the fourth reading elevation. The horizontal distance along the fourth reading elevation line from the originally plotted reading to the projected vertical line is the total out-of-plumb at that elevation.

Bearing and seal ring centerlines can be plotted by taking half of the difference between the north-south and east-west clearances and plotting that value against their respective shaft centerline plots. The bearing centerline will lie on the side of the shaft centerline in the direction of largest clearance reading. In the example on figure 24, the difference between the north-south readings is 0.040 inch. The centerline is half of that value, 0.020 inch to the north of the shaft centerline. In the east-west direction, the difference is 0.008 inch, so the bearing centerline is 0.004 inch to the west of the shaft centerline.

**Runout plots.** Once the shaft is determined to be straight and the position of the shaft relative to plumb is plotted, the runout data can be incorporated. As mentioned earlier, static runout is an indirect measurement of the perpendicularity of the thrust runner to the shaft. By incorporating the static runout data, the plumb of the center of runout can be determined.

When using plumb wires or a laser system, there are two methods that can be used to measure the static runout. The first requires rotating the shaft in 90-degree increments and taking plumb readings. The form on figure 21 should be used. Since the straightness of the shaft should already be verified, only the readings at the top and bottom elevations are taken. After all the readings have been taken, the runout calculations can be made.

The values in Column 5 are the values the shaft is out of plumb from the first to the fourth readings and will be transcribed to Column B of figure 22. To correct these values to reflect the out-of-plumb from the thrust bearing to the fourth elevation, a multiplication factor must be calculated. This factor, based on similar triangles, is  $(A+E)/E$ . Each of the values in Column 5 is multiplied by this factor and entered into the appropriate spot on the table. These values can then be plotted to show the runout diameter and its location relative to the thrust bearing.

An example of a runout plot is shown on figure 22. This plot is a top view. The origin of the plot (point 0,0) is the shaft centerline at the thrust runner elevation, or the center of the thrust runner. The points at 0, 90, 180, and 270 degrees are the positions of the shaft at the fourth reading elevation as the shaft is rotated. The intersection of the lines drawn from 0 to 180 and from 90 to 270 is considered the center of runout. A line drawn from the origin to the center of runout would be the axis of rotation for that unit. As mentioned before, the primary objective is to make the center of runout or the axis of rotation, plumb. In this plot, the center of runout will be plumb when it is located directly under the center of the thrust runner (point 0,0). How this is done will depend on the design of the thrust bearing. These specific procedures will be discussed in the next section. The runout diameter, the distance from 0 to 180 and from 90 to 270, should be checked at this point. The diameter can be checked graphically by simply measuring the distance on the plot.

When dial indicators are used with wires or a laser system, the form on figure 23 should be used. The plot of this data will be only the plot of the runout at the location of the lower dial indicators. The origin is the position of the shaft at 0 degrees. The center of runout is again the intersection of the lines from 0 to 180 and from 90 to 270 degrees. To correlate the runout plot to the plumb of the center of runout, one set of plumb readings is required at 0 degrees. In this example, the plumb data from figures 16 and 24 are used. The position of the thrust runner with reference to the runout plot can be determined by measuring the out of plumb from the thrust bearing to the elevation where the lower dial indicators are located on the plumb plot. For this example, we will assume that the dial indicators are located at the thrust bearing elevation and at the same elevation as the fourth plumb reading elevation. These values can then be used to plot the center of the thrust runner with respect to the 0-degree point. As with the other method of measuring static runout, the plot is a top view of the unit. To make the center of runout plumb, it is to be moved under the center of the thrust runner. This is accomplished by plumbing the unit as described in the next section.

### **2.5.1.2 Precision Level**

The precision level will provide a measure of the plumb of the center of runout of the shaft. By incorporating dial indicator data, the plumb and straightness of the shaft can be determined as

FIST Volume 2-1

Alignment of Rotating Machinery

well. Use worksheets on figures 25 and 26 to record that data from the level and dial indicators. The first step is to take level readings. With the level secured to the shaft at the 0-degree position and dial indicators mounted at all three guide bearing elevations, the shaft is rotated in 90-degree increments. The vertical distances between the indicators should be determined within 1 inch to ensure accuracy in the extrapolation of data from the indicators to determine shaft position. The level and indicators are read when it is confirmed that the shaft is hanging free. The level readings should be recorded to correspond with the direction of the level — i.e., north, south, east, or west — not the angle of rotation. This will eliminate confusion caused by rotating in different directions. The indicators can be referenced to the angle of rotation.

Unit alignment worksheet (precision level)

Calculation of Out of Plumb of Center of Runout							
	Column 1 Level reading	Column 2 Enter 0.004848 if reading in arc-sec, enter 1 if reading in mils/in	Column 3 Column 1 × Column 2	Column 4 Difference N-S E-W	Column 5 One-half of Column 4	Column 6 Total N+S, E+W from Column 3	Column 7 Inaccuracy (N+S) – (E+W)
North	95.1	0.004848	0.461	0.150	0.075	0.772	0.001
South	64.2	0.004848	0.311				
East	77.8	0.004848	0.377	-0.019	-0.0095	0.773	
West	81.7	0.004848	0.396				

Points for Plotting Center of Runout and Shaft Centerline						
		Out of plumb of center of runout in mils/inch	Coordinates for Plotting of center of runout	Coordinates of center of runout from Static Runout Plot	Coordinates of Shaft Centerline	
		Column A Distance from UGB Indicator	Column B Values from Column 5	Column C Column A × Column B	Column D Coordinates of Center of Runout from Static Runout Plot	Column E Coordinates of Shaft Centerline Column C – Column D
LG	North-South	(A) 160	0.075	12.0	-4.2	16.2
	East-West	(A) 160	-0.0095	-1.5	5.2	-6.7
TG/IG	North-South	(B) 250	0.075	18.75	-5.6	24.4
	East-West	(C) 250	-0.0095	-2.4	8.3	-10.7

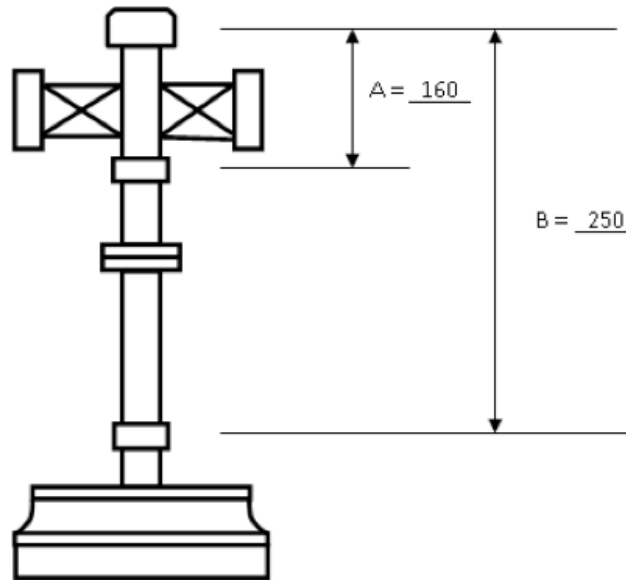

Figure 25.—Alignment worksheet (precision level).

FIST Volume 2-1  
Alignment of Rotating Machinery

Runout worksheet using dial indicators at three elevations

Plant: FIST 2-1			Unit: 1				Date:			
Notes:										
	0°		90°		180°		270°		360°	
	N	E	N	E	N	E	N	E	N	E
Upper Guide	0	0	0	1	1	-1	-1	0	1	0
Lower Guide	0	0	1	10	-8	10	-11	1	1	1
Turbine Guide	0	0	1	9	-9	11	-10	1	0	1
Corrected LGB Lower – Upper	0	0	1	9	-9	11	-10	1	0	1
Corrected TGB/PGB Turbine – Upper	0	0	4	15.5	-12.5	18.5	-13.5	2.5	0	0

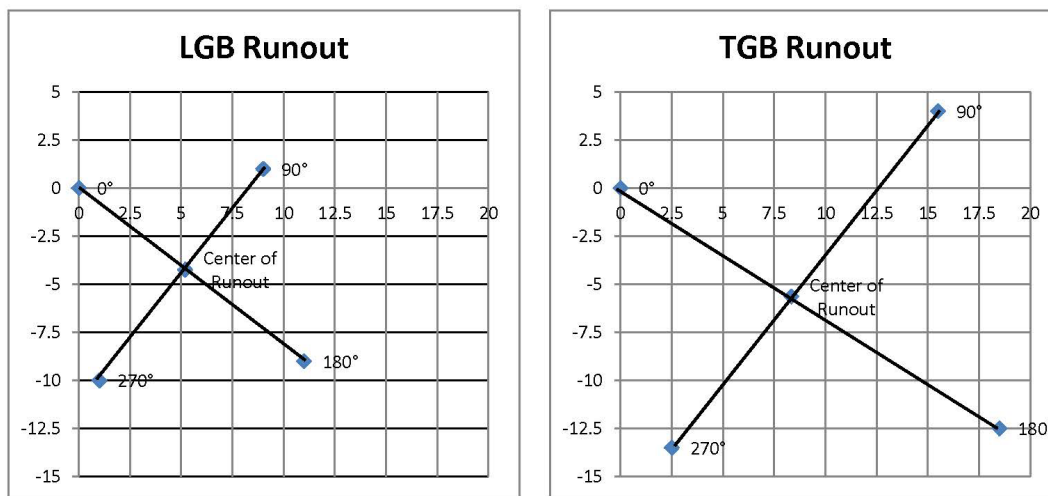

Figure 26.—Runout using indicators at three elevations.

Once the readings are recorded, they should be in a format that can be used for the calculations. To simplify calculations, the readings should be in mils per inch. A mil is 0.001 inch. A reading in mils per inch can be multiplied by the length of the shaft to obtain the out-of-plumb in mils or thousands of an inch. In Column 2 of figure 25, a correction factor is entered. If the level reads directly in mils per inch or micrometers per meter, a 1 is entered. If the level readings are in arc seconds, they will need to be converted to mils per inch. To accomplish this, a conversion factor is entered into Column 2. The conversion from arc seconds to mils per inch is described in the equations below.



$$P = \tan(\alpha/3600) \times 1000$$

or

$$P = 0.004848 \times \alpha$$

$P$  = level reading in mils/inch  
 $\alpha$  = level reading in arc seconds

Column 3 is the product of Column 1 is multiplied by Column 2. Column 4 is the difference north minus south or east minus west. Maintain correct signs; i.e., if south or west is the larger number, the sign will be negative. Column 5 is one-half of Column 4, which is the value that will be multiplied by the shaft length to determine the out-of-plumb of the center of runout. Again, use the correct negative or positive sign from Column 4. Columns 6 and 7 are used to calculate the accuracy of the readings. Column 6 is the sum of the north and south and east and west readings. Column 7 is the difference of the values in Column 6 and is a measure of the accuracy of the readings. This value should be less than 0.005.

To calculate the points for plotting the center of runout and shaft centerline, refer to the second table on figure 25. The distances from upper guide bearing indicators to the lower guide and turbine guide bearings should be entered into Column A. From manufacturer's drawings, determine the length of the shaft between the guide bearing locations where the dial indicators are located. It is also useful to obtain the distances to the top and bottom of the air gap, and the turbine seal rings as these may be plotted as well. The north-south and east-west values from Column 5 are entered into Column B. The coordinates for plotting the center of runout are determined by multiplying Columns A and B.

Column D requires referencing the runout plots for both the lower and turbine guide bearings on figure 26. The intersection of the lines connecting 0 to 180 and 90 to 270 is the center of runout. The north-south and east-west values of the center of runout can be taken directly off the plot and are entered into Column D. The vertical distance from the 0 point is the north-south value and the horizontal distance is the east-west value. North and east values are entered as positive and south and west values are entered as negative. Column E is the result of subtracting Column D from Column C. Once this table is completed, the shaft centerline and center of runout can be plotted (figure 27).

For the vertical scale, the plot will start at the upper guide bearing and extend down to the turbine seal rings. Mark the elevations for the upper guide, lower guide, and turbine guide bearings or the elevations where the dial indicators were located. Also mark the coupling elevation. Draw a straight vertical line on each plot to represent the plumb line. The origin for the plot will be at the upper guide elevation. The values for the center of runout plot are from Column C. Draw a straight line from the upper guide bearing to the lower and turbine guide points. This line will always be straight. It can be extended upward to the thrust bearing on units where the upper guide is below the thrust bearing. It will be extended downward to the turbine seal ring elevations. This line represents the plumb of the center of runout.

Alignment of Rotating Machinery

To plot the shaft centerline, again the upper guide bearing elevation will be the origin. Plot the values from Column E. Draw straight lines from the upper guide bearing points to the lower guide bearing points and extend these lines to the coupling elevation. Draw a line from the end of this line, at the coupling elevation to the turbine guide point. These lines represent the centerlines of the generator and turbine shafts. They should be close to straight. A check of shaft straightness can be accomplished by drawing a straight line from the upper guide point to the turbine guide point and measuring the distance from this line to the coupling on the shaft centerline plot. This should be less than 0.002 inch.

If the shaft centerline plots show a significant dogleg, several readings should be taken to verify its existence. If several readings consistently indicate a significant dogleg some action may be required. It is typically safe to assume the dogleg is at the coupling. If there is any reason to suspect that the one of the shafts is bent, the location of the bend can be pinpointed by taking dial indicator readings at other elevations. As long as the shaft is straight, the runout plots should be proportional in size and in the same direction. By taking readings at different elevations, the shift in the runout plot indicates that the bend is above that elevation. It will probably be necessary to build support brackets for the dial indicators if readings are desired at elevations other than at the guide bearings.

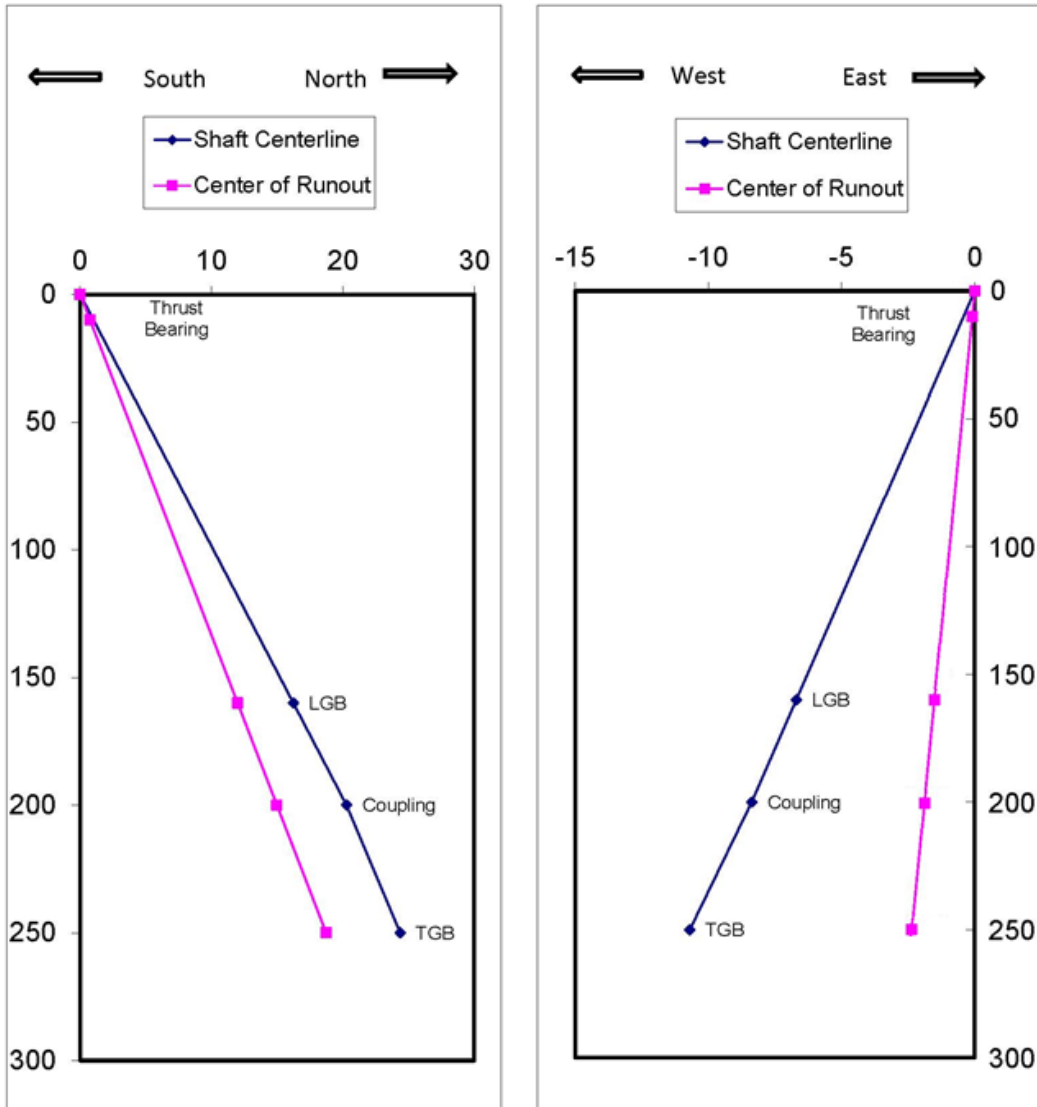

Figure 27.—Shaft and center of runout plumb plot (precision level).

## 2.6 Alignment Procedures

### 2.6.1 General

In general, the alignment of a vertical-shaft unit simply requires making sure that the thrust runner is perpendicular to the shaft and that the shaft is straight, and then making the necessary adjustments to move the shaft to the desired position. This usually means positioning the center of runout to correspond with the desired axis of rotation. In most cases that will mean plumbing the center of runout, but if the unit is slightly tilted, it may mean aligning the center of runout with the center of the stationary components. How these adjustments are made, depends on the design of the thrust bearing.

(FIST 007) 08/02/2016

NEW RELEASE

(Minor revisions approved 09/16/2016, 05/29/2024)

If the perpendicularity or straightness is out of tolerance, some correction may be required as described below. This can be done either before the plumb is adjusted or afterwards, depending on what works best with the schedule. The plumb adjustments are independent from any corrections that may be made to shaft straightness or the thrust runner. Plumb adjustments make the thrust bearing shoes level and, unless the bridge is removed as part of the correction, will not be affected by shimming the coupling or removing the thrust runner.

## 2.6.2 Correcting Excessive Dogleg and Offset

When a dogleg shows up on the shaft centerline plots, the first step is to verify that there is truly a bend in the shaft. The dogleg may be caused by the shaft not being completely free or simply by an error in the readings. Multiple readings should show exactly the same thing. If some readings show a dogleg and others do not, verify the procedure and that the shaft is free on all readings. If plumb wires or a laser system is being used, the shaft can be rotated 90 degrees and another set of readings taken. The dogleg should move from the north-south plot to the east-west plot or vice-versa. If the dogleg is still in the same plane, the shaft is likely not free.

If the existence of a dogleg is verified and the amount of dogleg is causing static runout measured at the turbine bearing to exceed the tolerance, some correction is required. In most cases, dogleg is caused by some issue in the shaft coupling. A burr may have been created when the coupling bolts were installed, or some dirt or other contaminants may be between the coupling flanges. To check for this, loosen the coupling bolts and split open the coupling wide enough for a visual inspection. If possible, the coupling should be split wide enough to allow the coupling flanges to be stoned. When recoupling the shafts, take care to correctly stretch the bolts. While in most cases it is nearly impossible to create or correct a dogleg with the coupling bolts, in a few cases new coupling bolts have been installed that are actually stronger than the flange material.

Once the coupling flanges have been cleaned, if the dogleg is still there and the runout is significantly above tolerance, it will be necessary to shim the coupling. When calculating the amount and placement of the shims to install in the coupling, having several consistent readings is important. Installing shims in the coupling can be a very time-consuming process and, preferably, should be done only once. Remember that the shims should be installed so that the shim pack creates a wedge to prevent distortion of the coupling. If the runout is only 2 to 3 mils over tolerance, it may be better to run the unit without shims. Each situation should be evaluated considering the benefits of installing the shims and the consequences of doing nothing.

Excessive offset occurs when the generator and turbine shafts are coupled together and are not concentric. Offset is very rare and would be the result of mis-machining during the original construction. If excessive offset is present, it usually requires realigning the shafts and re-boring the coupling for oversized bolt holes. On most couplings, there is also a register fit between the two shafts. If this is the case, the register fit will have to be machined as well.

### 2.6.3 Correcting Excessive Static Runout

In the event the measured static runout is greater than the recommended maximum allowable value, some correction will be required. Before any corrective action can be taken, the source of the excessive runout needs to be determined. The most likely cause is non-perpendicularity between the thrust runner and the shaft, but a dogleg or a bend in the shaft can also cause excessive runout. If the plumb readings and plots indicate that the shaft is straight, the problem lies in the thrust runner not being perpendicular to the shaft. This may be due to inaccuracies in machining or to an improper installation procedure. The thrust block is usually shrink-fitted onto the generator shaft. Normal procedures call for the weight of the unit to be put on the thrust block while it is still warm. If the block was allowed to cool before any weight was applied, it may cock slightly when weight is applied, causing the runner not to be perpendicular to the shaft. To minimize machining inaccuracies, the thrust block and keys should be match-marked to the shaft so that they can be installed in the same orientation as they were in before they were removed.

If the thrust block was installed properly and there is still a problem, some action may be required. There are several options when the runout or the perpendicularity is out of tolerance. The first option is to do nothing. This is the least desirable option, and the consequences should be considered. On an adjustable shoe or self-equalizing bearing, the pivot points will likely see more movement, which can lead to wear of these points. Vibration can also increase at the guide bearings. The amount of vibration and wear will depend how much the perpendicularity is out of tolerance. Anyone making the decision to do nothing should consider the condition of the bearing pivot points when the unit was torn down, the amount of runout measured during pre-teardown readings, and any vibration issues noted before the unit was shut down. If the runout was high on the pre-teardown readings but the pivot points showed little wear and vibration was not excessive, leaving the thrust block as it is may be acceptable. If, on the other hand, there was significant wear on the pivot points or significant vibration prior to shut down that wasn't a result of rough zone or balance issues, some correction is probably required.

Another option to correct the high static runout is to re-machine the thrust block or runner. If the runout issue was discovered during pre-teardown readings, the thrust block and runner can be sent to a machine shop that is capable of measuring and making the necessary corrections. In some cases, it may be necessary to build up the bore by welding and then re-machine it to achieve the desired fit and to make it perpendicular to the runner. If the bore diameter and fit are good, the runner or its matching surface on the thrust block can be machined to make it perpendicular. It should be noted that it is possible to make the thrust block and runner within tolerance and still have runout issues if there is an issue with the shaft. If the mating surface of the shaft is worn, or if the shaft has a bend near its top, there still can be excessive runout.

Another option is to just machine the thrust runner to make it perpendicular to the shaft. This can be done to compensate for issues with the shaft. The runner would be machined based on the calculations made from alignment data. This option requires that the fit of the thrust block on the shaft be acceptable so that when it is taken off and put on, there is no change in runout. If the shaft does not fit well, the thrust block can seat itself in a different position each time the block is

removed and replaced. It should be noted that this procedure can take several tries to get right. Since it requires taking the thrust runner off of the unit and shipping it to a machine shop, an outage may be extended considerably.

The final option is to install shims to make the runner perpendicular to the shaft. Shims are typically placed between the thrust runner and thrust block but may be placed between the radial key and the shaft or on the shaft ledge on clamp bar type thrust blocks.

Shims between the thrust runner and the thrust block can be effective but, especially on larger thrust blocks (i.e., > 48 inch diameter), the shims can wear away over time and create fretting corrosion between the mating surfaces. The shim pack should be installed to create a wedge and support as much of the thrust runner surface as possible. Adding smaller shims between shims in the wedge can help limit flexing. If a wedge is created using Shims 4, 3, 2, and 1 mil thick, there will usually be a gap between the strips of shim material. Adding an additional 3-mil shim between the 4- and 3-mil shims will not change the wedge and will limit the amount the runner can flex. Inserting a single shim on one side of the thrust runner will allow the runner to flex and will likely increase damage from fretting. Installing shims between the thrust runner and block should only be considered if the measured runout is significantly above the tolerance and it is not practical to perform other repairs.

On smaller units with clamp bar type thrust blocks (< 48-inch-diameter thrust blocks) it is possible to place a shim on the shaft ledge that the thrust block is clamped to, and make the thrust runner perpendicular to the shaft. Experience has found that no appreciable movement or wear occurs with the shim placed at this point even many years after the installation. Larger thrust blocks of this type tend to flex when the weight of the unit is supported by the block so that the shim isn't effective. When placing the shim on the ledge, it can be difficult to predict the size and length of the shim required. It typically takes several tries to get the desired effect. Since the thrust block must be heated and removed for each attempt, a day is lost every time a new shim is installed, as the block has to cool down overnight to reach ambient temperature.

There have been instances where installing shims between the radial keys and the shaft has had a positive effect on the perpendicularity. This is only possible if the fit between the shaft and the thrust block is loose. If this method does work, it indicates that the fit of the thrust block on the shaft is not adequate.

#### **2.6.4 Procedure for Spring-Loaded Thrust Bearings**

1. Take plumb and static runout readings. Plot the shaft profile and runout readings. If dogleg or offset is excessive, make corrections as discussed in section 2.6.2. If the magnitude of static runout exceeds the tolerance, make necessary corrections as discussed in section 2.6.3. Take clearance readings of the turbine seal rings, turbine bearing housing, generator stator, and generator guide bearing housings, if not adjustable. Plot the centerlines of the static components on the shaft plumb plots to determine concentricity.

The concentricity should be checked even if the stationary components were centered with a single plumb wire with the rotating components removed.

2. Determine the position of the center of the runout at the turbine guide bearing relative to the top of the shaft at the thrust bearing elevation. Ideally, in a perfectly plumb unit, the top of the shaft and the center of runout will correspond.
3. If the plumb of the center of runout is out of tolerance, calculate the thickness of shims for bridge legs to plumb the center of runout using either the graphical method or the analytical method described below. To prevent distortion, shims should be added to all except one leg of the bridge so that a wedge shape of shims is maintained.

#### **2.6.4.1 Graphical Procedure for Shim Calculation (Figure 28)**

1. Draw two circles and plot the bridge legs on graph paper. One circle will be used for the north-south orientation and one for east-west.
2. Plot the pivot axis on each circle. The pivot axis will line up with the measurement axis (i.e., north-south or east-west).
3. Plot the change in the bridge elevation point from the appropriate end of the pivot axis and connect the new elevation point by line to the opposite end of the pivot axis.
4. Project a line from the end of each leg perpendicular to the pivot axis. Count and tabulate the number of divisions from the shim line to the pivot axis along the projected line.
5. Total the divisions of both circles for each bridge leg and subtract the smallest total value from all the total values to determine the amount of shim to add to the legs.

#### **2.6.4.2 Analytical Procedure for Shim Calculation (Figure 29)**

1. Draw two circles and plot the bridge legs. One circle will be used for the north-south orientation and one the east-west.
2. Plot the pivot axis on each circle. The pivot axis will line up with measurement axis (i.e., north-south or east-west).
3. Project a line from the end of each leg perpendicular to the pivot axis. Calculate the distance along the pivot axis from the pivot point to the projected lines.
4. Calculate and tabulate the shims required for each bridge leg as follows:

$$SHIM = \frac{D_{pivot} \times P}{L}$$

Where:

$$D_{pivot} = \text{Distance from pivot point}$$
$$P = \text{Out of plumb of center of runout}$$
$$L = \text{Length of shaft from thrust bearing to turbine bearing}$$

5. Total shims north-south and east-west for each bridge leg, and then subtract the smallest total value from all the total values to determine the thickness of shims to add to the legs.
6. After the shims are installed, retake plumb and runout readings. If the plumb of the center of runout is still out of tolerance, recalculate the shims. Note: In some installations, due to a low spring constant (soft springs), the calculated shims may not give the desired effect. In these cases, simply add more shims until the plumb is acceptable.
7. Move the shaft so that the centerline of the thrust runner is directly over the center of the turbine bearing housing. Since the center of the runout is plumb, this will also make the center of runout concentric with the turbine bearing housing. Lock the thrust runner in place with jacking bolts or bearing segments in preparation for guide bearing installation. See section 2.7 for guide bearing installation procedures.



Graphic Shim Calculation - 6 Legged Bridge

Given Data  
 Shaft Length = 434.5  
 Bridge Diameter = 180  
 Out of Plumb of Center of Runout 0.0037 West 0.032 South  
 Change in Bridge Leg Elevation =  $\frac{(\text{Distance from Pivot Point})(\text{Out of Plumb})}{\text{Shaft Length}}$

East West =  $\frac{(180) 37}{434.5} \approx 15$  mils  
 North South =  $\frac{(180) 32}{434.5} \approx 13$  mils

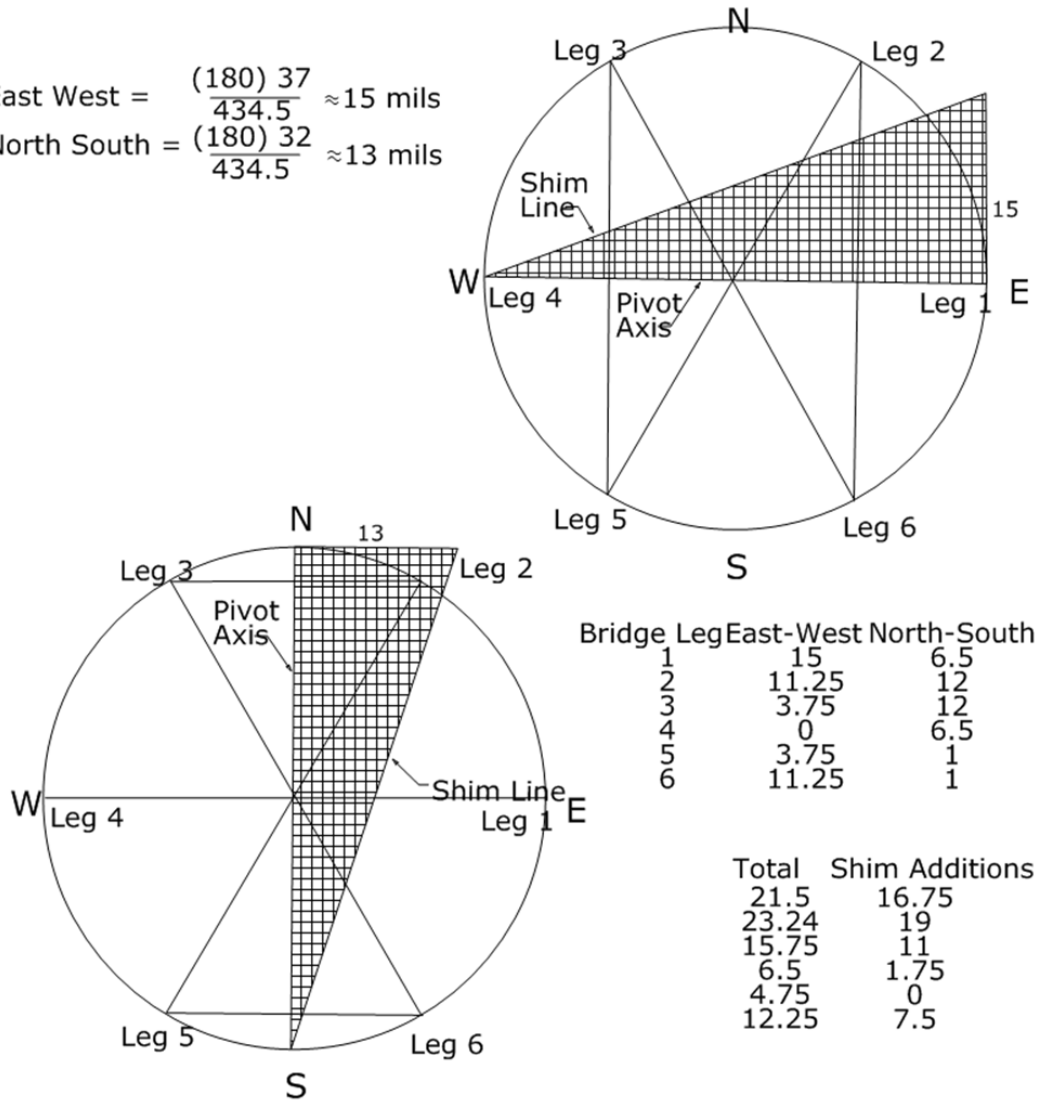

Figure 28.—Graphical procedure for shim calculation (shim thickness in mils).

**FIST Volume 2-1**  
**Alignment of Rotating Machinery**

Given Data  
 Shaft Length = 434.5  
 Bridge Diameter = 180  
 Out of Plumb of Center of Runout 0.0037 West 0.036 South  
 Change in Bridge Leg Elevation =  $\frac{(\text{Distance from Pivot Point})(\text{Out of Plumb})}{\text{Length of Shaft}}$

East West

$$\text{Leg 1} = \frac{(180) 37}{434.5} = 15.3 \text{ mils}$$

$$\text{Legs 2+6} = \frac{(135) 37}{434.5} = 11.5 \text{ mils}$$

$$\text{Legs 3+5} = \frac{(45) 37}{434.5} = 3.8 \text{ mils}$$

Leg 4 is the Pivot Point = 0 mils

North South

$$\text{Legs 1+4} = \frac{(77.94) (32)}{434.5} = 5.74 \text{ mils}$$

$$\text{Legs 2+3} = \frac{(155.88) (32)}{434.5} = 11.48 \text{ mils}$$

Legs 5+6 = 0 mils

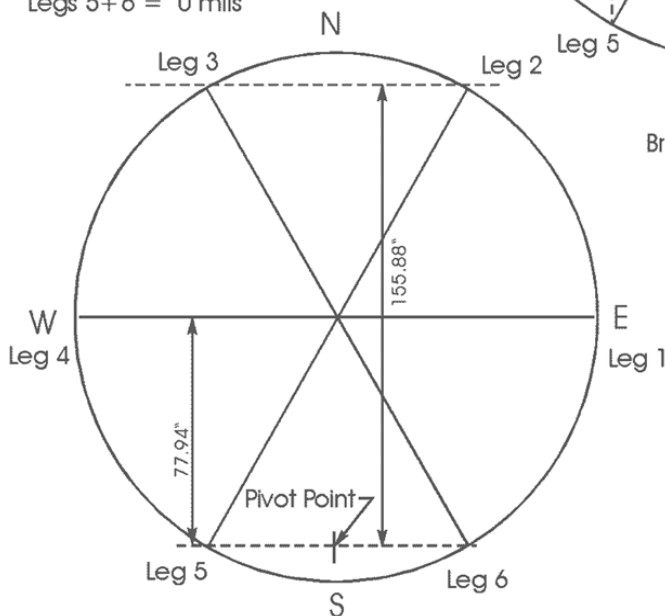
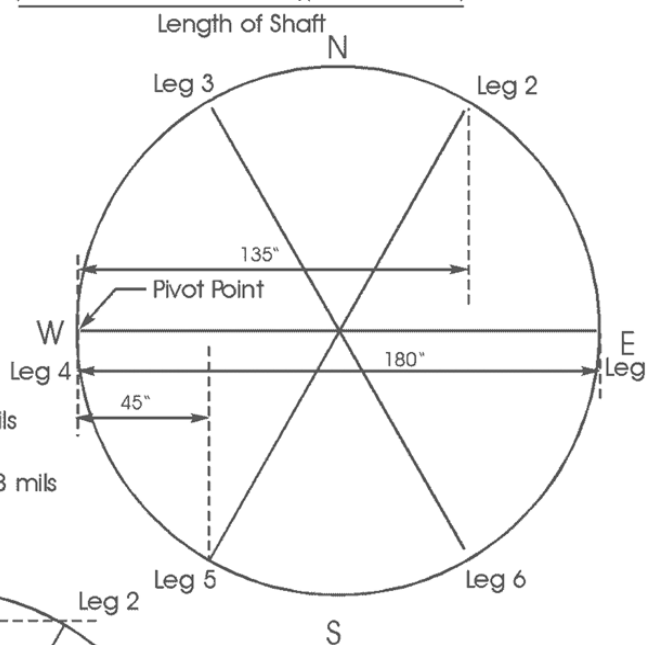

Bridge Leg	East-West	North-South
1	15.3	5.74
2	11.5	11.48
3	3.8	11.48
4	0	5.74
5	3.8	0
6	11.5	0

Total	Shim Additions
21.04	17.24
22.98	19.18
15.28	11.48
5.74	1.94
3.8	0
11.5	7.7

Figure 29.—Analytical procedure for shim calculation (shim thickness in mils).

**2.6.5 Procedures for Adjustable Shoe Thrust Bearing**

The goal in aligning adjustable shoe thrust bearings is to adjust the shoes so that they are equally loaded, and the center of runout is plumb. It doesn't matter how you get there as long as that goal is achieved. Any of the methods listed below or combinations of the procedures can adequately plumb the unit and equalize the loading on the shoes.

(FIST 007) 08/02/2016  
 NEW RELEASE

### **2.6.5.1 Adjustable Shoe Thrust Bearing – General**

1. Take plumb and static runout readings. Plot the shaft profile and runout readings. If dogleg or offset is excessive, make corrections as discussed in section 2.6.2. If the magnitude of static runout exceeds the tolerance, make necessary corrections as discussed in section 2.6.3. Take clearance readings of the turbine seal rings, turbine bearing housing, generator stator, and generator guide bearing housings, if not adjustable. Plot the centerlines of the static components on the shaft plumb plots to determine concentricity. The concentricity should be checked even if the stationary components were centered with a single plumb wire with the rotating components removed.
2. Determine the position of the center of runout at the turbine guide bearing relative to the top of the shaft at the thrust bearing elevation. Ideally, in a perfectly plumb unit, the top of the shaft and the center of runout will correspond.
3. Cleaning up the threads on the jack screws prior to the alignment will make the adjustments smoother and more even between screws.
4. Determining when the load is equalized between the thrust shoes using the procedures below can be somewhat subjective. While in most cases these procedures provide acceptable results, it may be desirable to actually measure the loading on each shoe. Some adjustable shoe thrust bearings are equipped with load cells to measure the exact loading on each individual shoe. In most cases, these load cells are simply strain gages attached to each jack screw. When new and calibrated, these can provide an accurate measurement of the load, but after they have sat submerged in oil for 20 years or more, their accuracy is questionable. If one wishes to use the load cells, the individual jack screws should be removed and the calibration of each load cell verified. In most cases, the strain gage should be removed and a new gage installed.
5. If the jack screws were removed or new shoes are installed, the loading on the shoes can vary significantly when the alignment is started. When load cells aren't available, it is possible to get a rough idea of the loading on the shoes by installing pressure gauges on each of the high-pressure lubrication lines to each of the shoes. With the high-pressure lubrication turned on, the gauges will show which shoes are very highly or very lightly loaded. This data can be used to adjust the loading when the unit is first assembled. It should be noted that variations in the flow to each shoe may affect the measured pressure, so these readings should only be used as an estimate of the shoe loading.

### **2.6.5.2 Adjustable Shoe Thrust Bearing – Method 1**

This procedure utilizes dial indicators to monitor the position of the shaft as the shoes are loaded. The shoes are loaded in a sequential order to gradually move the shaft in the desired direction. This gradual movement also serves to help equally load the shoes. Once the shaft is in position, the jack screws are all lightly loaded while the movement at the turbine bearing is observed. If it is verified that each shoe moves the same amount, the loading should be close to equal, and the

shaft should be back to its desired position. If strain gages or other methods are available to verify loading, they can be used to fine tune the adjustment.

1. From the plumb and runout readings, make a plot of the present position and the desired position of the center of runout at the turbine guide bearing. It can be helpful to make a sketch of the thrust bearing and the relative location of the shaft.
2. Check to confirm the shaft is free and zero the dial indicators at the turbine guide bearing elevation and at the thrust bearing elevation. There should be two indicators per elevation. Jacking bolts, or guide bearing shoes, at the upper guide bearing should be snugged tight to prevent skating at the thrust bearing.
3. Start loading with the high shoe, hitting the slugging wrench just hard enough to get 0.005 to 0.001 inch of movement of the shaft at the turbine bearing. Check for a free shaft. If the shaft is not free, turn on the high-pressure oil lift system and move the shaft at the thrust bearing until it is free. Subtract the dial indicator readings at the thrust bearing from the readings at the turbine bearing and record the corrected value, plot the point, and label it with the number of the shoe. Figure 30 is an example of a table for recording the dial indicator and a plot of the data.
4. Moving to the next shoe, hit the slugging wrench to achieve more movement than the first shoe had. Again, check for a free shaft, make it free if it is not, record the readings, and plot the point. Continue loading each successive shoe, increasing the amount of movement for each shoe until the low shoe is loaded. After loading the low shoe, the movement should be decreased until the starting shoe is reached. When adjusting the shoes, never unload a shoe and never skip shoes.
5. The plot of the points will create a spiraling pattern as the shoes are loaded (figure 30). It may take several rounds to move the center of runout to the desired position. Keeping track of the plot during the loading will help determine how hard or how many times to hit the slugging wrench. Once the center of runout is at the desired position, all of the shoes should be loaded one more time, striking each shoe just hard enough to get approximately 0.0005-inch movement. The purpose of the final round is to ensure that each shoe is equally loaded. The plot of the final round should be a circle. For the final round of loading, dial indicators equal to the number of thrust shoes can be installed at the turbine bearing lining up with each shoe. Each shoe can then be loaded while one observes its corresponding indicator. Each shoe should be loaded so that each indicator moves exactly the same amount.

Dial Indicator Readings

Thrust shoe number	Bottom		Top		Corrected	
	North-South	East-West	North-South	East-West	North-South	East-West
5	-1	-2	0	0	-1	-2
6	-3	-3	0	0	-3	-3
7	-5	-2	0	0	-5	-2
8	-8	9	0	1	-8	-8
1	0	27	0	1	0	26
2	2	32	0	1	2	31
3	22	27	0	1	22	26
4	24	22	0	1	24	21
5	24	20	1	1	23	19
6	22	19	1	1	21	18
7	19	20	1	1	18	19
8	18	29	1	2	17	27
1	26	41	1	2	25	39
2	32	43	1	2	31	41
3	36	42	1	2	35	40
4	37	40	1	2	36	38
5	36	38	1	2	35	36
6	34	37	1	2	33	35
7	33	39	1	2	32	37

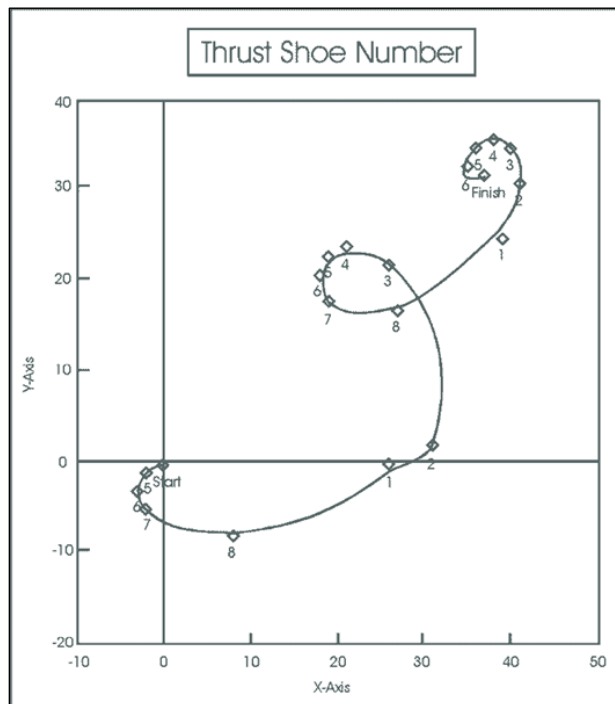

Figure 30.—Adjustable shoe thrust bearing loading readings and plot.

Alignment of Rotating Machinery

6. Take plumb and runout readings again to verify the position of runout. Reload shoes if out of tolerance. Take hard micrometer readings at the turbine bearing housing to determine the relative position of the turbine bearing center.
7. Move the shaft so that the centerline of the thrust runner is directly over the center of the turbine bearing housing. Because the center of runout is plumb, it will be concentric with the turbine bearing housing. Lock the thrust runner in place with jacking bolts or bearing segments in preparation for guide bearing installation. See section 2.7 for guide bearing installation procedures.

**2.6.5.3 Adjustable Shoe Thrust Bearing – Method 2**

This procedure requires shimming the thrust bearing support bridge, as is done with spring-supported bearings, to make the center of runout plumb. Once this is accomplished, the thrust bearing jack screws are used to equalize the loading on the individual thrust shoes.

1. If the plumb of the center of runout is out of tolerance, shim the bridge according to the procedure in section 2.6.4.
2. When the center of runout is plumb, set up dial indicators at the turbine bearing at positions corresponding to the thrust shoe positions. One indicator will be required for each pair of diametrically opposed thrust shoes. If available, an indicator for each shoe is preferable.
3. Start at any shoe and strike the slugging wrench. It is important that the same person do all the loading on the shoes so that they can get a “feel” for the loading.
4. Continue loading each shoe until a “hit” on a shoe provides the same movement on the corresponding dial indicator for each shoe. The shoes should be equally loaded at this point. Note: If calibrated load cells are available, they can be used to equalize the loading on the shoes.
5. Unless the shoes were very close to being equally loaded initially, the center of runout may have moved significantly. Shim the bridge according to the procedure in section 2.6.4 to again plumb the center of runout.
6. Load all the shoes one more time, hitting each shoe equally while watching the dial indicators. As the final shoe is hit, the center of runout should be back at its original position.
7. Move the shaft so that the centerline of the thrust runner is directly over the center of the turbine bearing housing. Because the center of runout is plumb, it will be concentric with the turbine bearing housing. Lock the thrust runner in place with jacking bolts or bearing segments in preparation for guide bearing installation. See section 2.7 for guide bearing installation procedures.

#### **2.6.5.4 Adjustable Shoe Thrust Bearing – Method 3 (Slugged Arc)**

This procedure relies on a good “feel” for when the shoes are equally tight using a slugging wrench and by hand. To achieve a consistent “feel,” it is advisable that the same person takes all the slugged readings, and the same person takes all the hand tight readings. To help prevent introducing variables into the amount of tightness, the jack screw threads should be cleaned up and lubricated before using this procedure.

1. Fabricate an arc scale to accurately measure the position of the wrench. Preferably, a scale should be made for each jack screw. The slugging wrench should have a pointer attached to help measure the angle accurately.
2. If the center of runout is significantly out of plumb, it may be necessary to roughly plumb the unit prior to adjusting the loading. This can be done by adjusting the low shoes while watching the dial indicators. The plumb can also be roughly adjusted by calculating the amount to turn each jack screw based on the amount the runout is out of plumb, the diameter of the jack screw bolt circle, and the thread pitch of the jack screws. In either case, it is best to adjust all of the shoes so as not to end up pivoting on a few shoes.
3. Using the slugging wrench and hammer, tighten all of the screws to the same apparent loading. Record the position of the arc scale. This is the slug tight reading.
4. Starting with any screw, loosen the screw until it is free of load. Then tighten the screw with the wrench by hand until it just starts to take load and record the position of the arc scale. This is the hand-tight reading. Retighten the screw to its slug-tight position and proceed to the next screw.
5. The arc between the slug-tight and hand-tight readings is the slugged arc. The slugged arc should be determined for each jack screw.
6. Calculate the average slugged arc for all of the screws. To equalize the loading, move each screw halfway to the average reading. For example, if the slugged arc of a particular screw is 15.55 inches and the average is 10.65 inches, the screw should be moved back 2.45 inches.
7. When all of the screws have been adjusted, repeat the process until the slugged arcs are equal.
8. When the loading is equal, check the plumb of the center of runout. If the plumb is out of tolerance, the shoes should be carefully adjusted to make it plumb.
9. After any adjustment of the shoes for plumb, the loading should be rechecked.
10. Move the shaft so that the centerline of the thrust runner is directly over the center of the turbine bearing housing. Since the center of runout is plumb, this will also make it concentric with the turbine bearing housing. Lock the thrust runner in place with jacking

bolts or bearing segments in preparation for guide bearing installation. See section 2.7 for guide bearing installation procedures.

## **2.6.6 Procedure for Self-Equalizing Thrust Bearing**

The design of the self-equalizing bearing allows the plane of the thrust bearing surfaces to move to match the surface of the thrust runner, wherever it is moved. Unlike spring bearings that are shimmed to move the bearing plane, or adjustable shoes, where each individual shoe is adjusted, self-equalizing bearings will move the thrust bearing plane to match the surface of the thrust runner while maintaining equalized loading on each shoe. For plumb purposes, this means that the shaft simply has to be pushed to center, and the shoes will automatically move to the proper level. Before that can be done, though, the perpendicularity of the runner to the shaft must be determined. Unlike the other bearings described here, self-equalizing bearings preclude the possibility of measuring the perpendicularity by the static runout method. To measure the perpendicularity takes a different procedure as described below.

The tolerance for perpendicularity between the thrust runner and shaft is the same as it is for other bearing types. That is, 0.002 inch across the face of the thrust runner. To measure this requires holding the shaft steady as it is rotated, measuring the up and down movement of the outside diameter of the thrust runner or the outer edge of a thrust bearing segment.

### **2.6.6.1 Perpendicularity – Self-Equalizing Bearing**

1. Fabricate steady rests or jacking bolts for the turbine guide bearing elevation that are capable of holding the shaft to under 0.001 inch lateral movement. Preferably the jacking bolts should have roller bearings.
2. Install guide bearing shoes at the upper guide bearing and snug them in place if feasible. If not, fabricate jacking bolts similar to those made for the turbine guide bearing.
3. Set up dial indicators at the upper and turbine guide bearing elevations. Set up at least one dial indicator to measure the up and down movement of the thrust runner. This can be measured directly on the thrust runner or on a bearing shoe, whichever is most convenient.
4. Rotate the shaft slowly. Verify that any lateral movement at either bearing is less than 0.002 inch. Record the up and down movement of the thrust runner.
5. If the up and down movement is more than 0.002 inch, some correction to the thrust block/runner may be required as described in section 2.6.3.

### **2.6.6.2 Alignment – Self-Equalizing Bearing**



1. Use a precision machinist level to level the upper bridge (lower bridge on an umbrella unit). Level should be measured on a machined surface parallel to the surface of the bearing support. Although self-equalizing bearings are designed to compensate for an out-of-level base, it is prudent to start with a level base.
2. Take plumb and static runout readings. Plot the shaft profile and runout readings. If dogleg or offset is excessive, make corrections as discussed in section 2.6.2. If the magnitude of static runout exceeds the tolerance, make necessary corrections as discussed in section 2.6.3. Take clearance readings of the turbine seal rings, turbine bearing housing, generator stator, and generator guide bearing housings, if not adjustable. Plot the centerlines of the static components on the shaft plumb plots to determine concentricity. The concentricity should be checked even if the stationary components were centered with a single plumb wire with the rotating components removed.
3. Move the shaft to center in the turbine bearing housing and move the top of the shaft to make it plumb.
4. Hold the shaft in place at the upper guide and turbine guide bearings using jack bolts or bearing segments in preparation for guide bearing installation. See section 2.7 for guide bearing installation procedures.

## 2.7 Guide Bearing Installation and Adjustment

The final step in the alignment process is the installation and adjustment of the guide bearings. While the plumb of the center of runout and the loading of the thrust shoes is very important, the installation of the guide bearings determines the concentricity of the unit. The guide bearings are to be installed concentric with one another as well as with the generator and turbine. The clearances must be within tolerance: If they are too loose, vibration levels will be high; if too tight, bearing temperatures will be high. To ensure that the entire alignment provides the desired results, a great deal of care should be taken when installing the guide bearings.

On a plumb unit, the centerlines of the bearings should be plumb and concentric. In order to achieve this type of installation, the shaft must be used as a reference, either to actually set the bearings shoes or, in the case of sleeve bearings, verify the center is where it should be. While it is possible to leave the shaft in any position and calculate bearing clearances, it is easier to place the shaft so that it corresponds with the centerline of the unit and lock it in place. Prior to making any moves, it is recommended that inside micrometer readings be taken at several points. This is to allow the shaft to be moved back to its original position in the event a dial indicator is bumped or otherwise compromised.

The final step in the procedures in section 2.6 calls for moving the shaft at the thrust bearing so that the centerline of the thrust collar is directly over the centerline of the turbine bearing housing. This essentially makes the center of runout plumb in the turbine bearing. The shaft will not be centered in the turbine bearing at this point due to the non-perpendicularity of the thrust

runner to the shaft. The shaft should be off center in the turbine bearing a distance equal to half the runout diameter. With the thrust collar locked in position, the shaft should be pushed to center in the turbine bearing housing with jacking bolts and locked in place. This should make the shaft plumb and provide a reference for installing the bearings.

### 2.7.1 Sleeve-Type Journal Bearings

Sleeve-type journal bearings may be held in position by dowels, a tight fit, or a tapered fit. Bearings with dowels typically have some clearance between themselves and the bearing housing. This allows slight adjustment to center the bearing. If it is necessary to move the bearing, it will have to be re-doweled as well. This may require a larger dowel or a new dowel hole depending on the bearing's design.

The center of a sleeve bearing that has a tight fit in the bearing housing is determined by the location of the housing. Prior to installation of the bearing, inside micrometer readings from the housing to the shaft should be taken to verify that the housing is in the correct position. Moving the housing on generator bearings usually requires moving the upper or lower bridge and re-doweling. Moving the turbine bearing housing can be much more complicated, as the turbine bearing housing, in many cases, also supports the wicket gate operating ring. In any case, the amount the bearing housing is out of center should be evaluated and the consequences of not moving it should be determined.

Once the bearing is installed, the clearances between the shaft and the bearing should be verified, both by feeler gauges and by jacking up the shaft and measuring movement with dial indicators. This is to verify that the expected clearance is available and that the bearing center is correct. Newly re-babbitted bearings may have imperfections in the machining such as high spots or tapers, which are difficult to measure with the bearing on the floor. Even if feeler-gauge measurements show no problem, the bearing may have high spots or a taper that can only be seen by jacking up the shaft. If the full expected clearance is not available when the shaft is jacked, it may be necessary to remove the bearing and scrape some of the high spots by hand. In worst-case scenarios — if the diameter is just too small or a taper is too severe — it may be necessary to send the bearing to the machine shop to be re-bored.

Measuring the installed clearance also ensures that the bearing center is correct. It is not uncommon for sleeve bearings that are supposed to have tight fits in their housing to actually have some clearance. This may allow the bearing to move to one side or the other of the housing and put the shaft in a bind. If this condition is found, the bearing will have to be centered to the shaft and secured by some means. This may be done by placing shims between the fit and the bearing, or possibly by installing dowels. The situation will have to be evaluated to determine the best plan of action.

Some turbine manufacturers have used tapered fits on the turbine bearing. In this design, the fit between the bearing and its housing is tapered, usually 1 inch per foot. As the bearing is tightened into the housing, the taper serves to keep the bearing centered and to tightly hold the

bearing in place. There are several issues with this design. As the bearing is driven farther into the fit, eventually the bearing will start to distort, and the clearances will get tighter. To prevent distortion of the bearing, the flange nuts should be carefully tightened, making sure that the bearing is being drawn into the fit evenly and that it remains level. The clearances of the bearing should be monitored by feeler gauges and by jacking up the shaft while the bearing flange nuts are tightened. When there is any reduction of the clearances, tightening the flange nuts should be stopped.

The tapered-fit bearing is designed so that the bearing flange never seats on the bearing housing. As each flange nut is tightened, the bearing is driven farther into the fit and all of the other flange nuts then become loose. This makes it impossible to fully tighten all of the flange nuts. In order to secure the bearing in place once it is as far into the fit as it can be without distortion, a block or jacking bolts can be installed for the flange bolts to tighten against. This can be done simply by installing the jacking bolts that are used to pull the bearing out of the fit when removing the bearing. Usually there are four bolts. They are installed and made snug. The flange nuts can then be tightened against the bolts. This prevents the bearing from moving or backing out from its fit during operation.

Another option to secure the bearing is to fabricate spacers to fit between the bearing flange and the housing. This requires tightening the bearing to a point where it just starts to deform, measuring the gap between the flange and the housing, and machining spacers. In most cases this will also require jacking the bearing back out to allow the installation of the spacers.

## 2.7.2 Adjustable Shoe Bearings

Adjustable shoe guide bearings are made up of a number of bearing shoe segments. Each segment pivots on a jack screw that can be adjusted to vary the clearance between the shoe and shaft. This simplifies making the center of a bearing concentric with the other bearings and other stationary components of the unit.

With the shaft pushed to plumb, each bearing segment is adjusted to the manufacturer's recommended clearance by adjusting the jack screw. While this sounds straightforward and simple, there are considerations that complicate the procedure.

Typically, the jack screw has a spherical point mating with a flat surface on the back of the bearing shoe. There are retainers for the bearing shoe, but it is free to pivot in all directions on the jack screw. This can make it difficult to hold the shoe while checking the clearance. Some shoes incorporate a slot that runs from the top to the bottom of the shoe at the pivot point. This type of design allows the shoe to be held tight against the shaft so that the clearance between the jack screw and the shoe can be measured. On other designs, the pivot point is recessed in the shoe, so it is not possible to measure this clearance and, instead, the clearance between the shoe and shaft must be measured.

Where it is necessary to measure the actual bearing clearance, the shape of shoe should be considered. Due to a preload of the bearing, the clearances at the center of the shoe may be different than those measured at the outer edges. Preload is a design consideration that is used to affect bearing stiffness and damping. A bearing shoe with preload will be machined to a radius larger than simply the shaft radius plus the assembled clearance; figure 31 illustrates this. By definition the bearing preload is:

$$Preload = 1 - \frac{R_b - R_s}{R_p - R_s}$$

Where:  $R_b = \text{Bearing Assembled Radius}$

$R_p = \text{Shoe Machined Radius}$

$R_s = \text{Shaft Radius}$

The actual preload on a particular bearing isn't important in setting the clearance, but the fact that the clearance varies over the face of the shoe does make setting the clearance with a single feeler gauge very difficult. Because the clearance at the edges can be larger than the clearance in the middle, and since the shoe is free to move in practically any direction, it is best to snug the shoe against the shaft with multiple feeler gauges, or with a piece of shim stock that will cover the entire face of the bearing shoe, between the shoe and the shaft. The shim stock can be effective, as the shoe is square against the shaft and the minimum clearance will be equal to the shim installed.

The jacking bolts are equipped with locking nuts to hold the shoe in place once the jack screw is adjusted. It is important that lock nuts be adequately tightened so that the jack screw doesn't back out during operation. It is also important that the clearances be rechecked after the locknuts are tightened. Tightening the locknuts will stretch the bolts to some extent. It may or may not be enough to change the clearance. If tightening the locknut is changing the clearance, it may take some experimentation to achieve the desired final clearance.

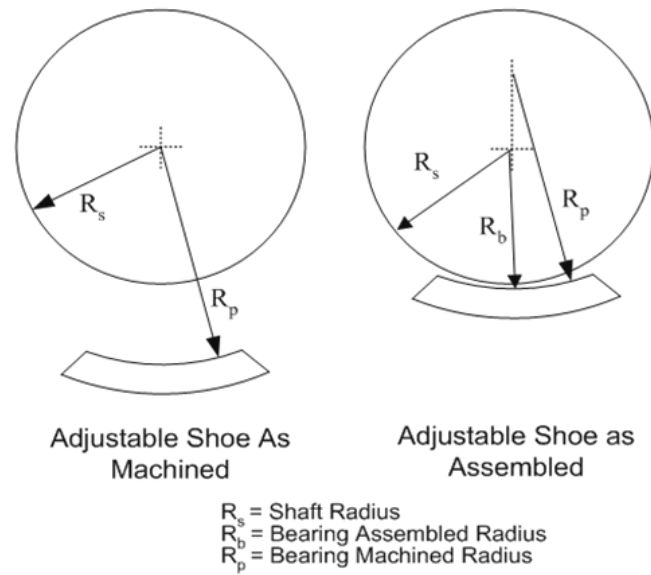

Figure 31.—Actual bearing clearances.

Once all the bearings are set, the clearances should be verified by jacking up the shaft. The movement in the bearing should be within the manufacturer's recommended tolerance for that bearing. It is recommended that the clearances be checked in eight directions.

### 2.7.3 Final Assembly and Startup

Once the bearings are installed and the clearances verified, the rest of the assembly can be completed. The upper guide bearing and thrust bearing on underhung units should have their insulation checked per FIST 3-11, Generator Thrust Bearing Insulation and Oil Film Resistance. Calibrated temperature probes should be installed. The clearances on bearing covers and vapor seals should be checked. Oil levels should be checked. Proximity probes, if so equipped, should be installed.

When the unit is ready for startup, personnel should be stationed around the unit and be in radio contact with the operator. The wicket gates should be just cracked and immediately closed so that the unit begins rotating slowly. If there are any unusual sounds or any indication that any part is rubbing, the source of the sounds or rubbing should be investigated and corrected. If nothing unusual is noticed when the unit is bumped, it should be brought to partial speed and allowed to stabilize for several minutes. If nothing unusual is noticed, the unit can be brought up to full speed in steps, with personnel checking for abnormal increases in vibration or temperature as the speed increases. Once the unit is operating at normal synchronous speed, off-line, it should continue to be operated until the bearing temperatures stabilize.

FIST Volume 2-1  
Alignment of Rotating Machinery

Bearing temperatures and shaft runout should be compared to pre-shutdown data if it is available. The rate at which the bearing temperature rises should be compared to the pre-shutdown rate. It should be noted that if re-babbitted sleeve bearings are installed or if the clearances were decreased on adjustable shoe bearings, the temperature may rise more quickly and may peak higher. In these cases, the temperatures should be watched to make sure they are stabilizing at a reasonable level.

Vibration levels should also be compared to pre-shutdown levels. These can also change due to tighter bearing clearances and changes in the alignment. The runout should not be considerably larger than noted in the pre-shutdown readings. If work was done on the generator rotor during the outage, higher runout may mean that the rotor needs to be balanced. The runout in most cases should not be less than 1 mil in diameter. Extremely small runout, coupled with higher bearing temperatures may indicate that a guide bearing is not concentric with the other bearings and is putting the shaft in a bind. Further analysis of the vibration data can be useful. When two proximity probes are installed, 90 degrees apart at each bearing location, it is possible to plot the shaft of the runout or orbit. Performing fast Fourier transform (FFT) analysis on the data will provide a breakdown of the various frequencies occurring in the data. Misshapen orbit plots or FFT plots with peaks at multiples of the running frequency are indications that the shaft is rubbing in the bearing. Figure 32 shows orbit and FFT plots for identical units. The alignment of the first unit would be considered to be good. All of the bearings are concentric and the orbit plots are fairly round and have a reasonable diameter. The FFT plot shows all of the vibration occurring at the running frequency of the unit. The second unit shows a misshapen orbit at the upper guide bearing and multiple peaks on the FFT plot. There is a definite rub in the bearing. In this particular case, the shaft shifted slightly before the upper guide bearing was set.

Bearing rubs by themselves are not uncommon and do not usually require action. When a bearing rub coincides with higher-than-normal bearing temperatures, action may be required. When the orbit is simply truncated and bearing temperatures are normal or only slightly elevated, the bearing is not being overloaded and no damage is likely. When the orbit is less than 1 mil in all directions and the bearing temperature is significantly higher or doesn't appear to be stabilizing, the bearing may be overloaded, which potentially could lead to a wiped bearing. If there is any doubt, it is advisable to shut the unit down, recheck bearing clearances, and confirm that the shaft is free to move in all directions. In some cases, some components may shift once the unit starts and put one of the bearings in a bind.

**Orbit and FFT plots – good alignment:**

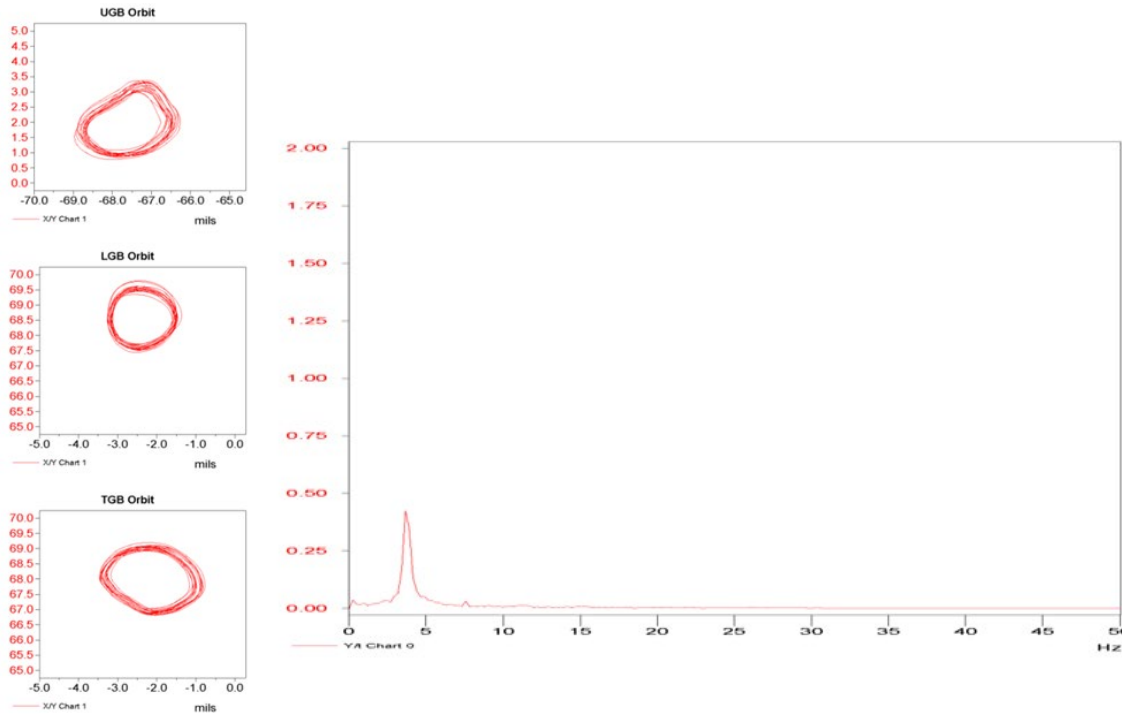

**Orbit and FFT plots – bearing rub:**

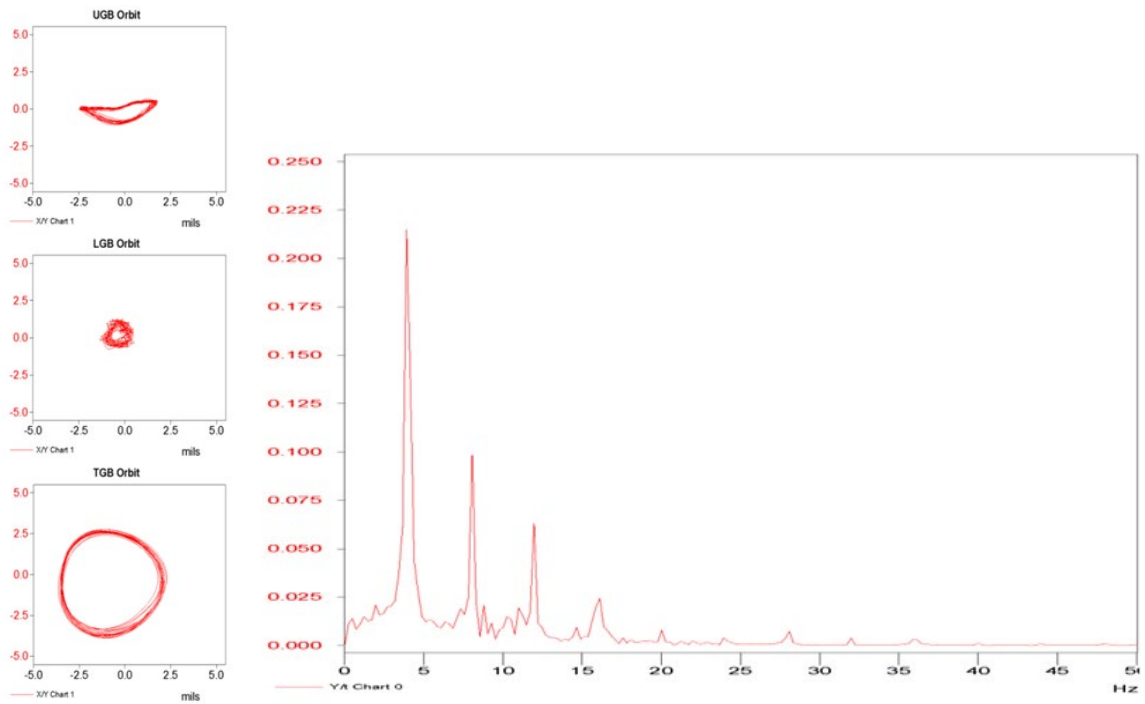

Figure 32.—Orbit and FFT plots.

## **3.0 Horizontal Shaft Units – Hydroelectric and Large Pump Units**

Reserved; under development.



## 4.0 Vertical Shaft Auxiliary Equipment

Reserved; under development.

## 5.0 Horizontal Shaft Auxiliary Equipment

---

**Note: The information in this section is applicable to all equipment that has a driver (e.g., motor) and driven equipment (e.g., pump). The following information uses terminology for the alignment of a motor to a pump because these components most often require alignment at Reclamation facilities.**

---

### 5.1 Horizontal Shaft Alignment

Horizontal pumps are typically coupled to the pump driver with a flexible coupling. The amount of misalignment a flexible coupling can tolerate depends on the design and characteristics, such as speed and torque, of the machines being coupled. The coupling's manufacturer should provide installation instructions indicating the allowable tolerances for a particular design. A horizontal pump usually can be aligned acceptably by either the face and rim method or the reverse indicator method. In most cases, the pump driver is aligned to the pump, as the pump is usually connected to rigid piping and is more difficult to move.

There are a number of laser alignment systems available for horizontal shaft alignment. These systems typically have a laser that mounts to one shaft and a target that mounts to the other shaft. A microprocessor takes the data from the laser and target and calculates the required movement and shim placement. These systems greatly reduce the time required for the alignment process.

#### Preliminary Checks for Alignment of Horizontal Pumps

1. At least 0.125 inch of nonrusting shims should be installed under each leg of the motor to allow for adjustments that may be required during the alignment procedure.
2. Compensation should be made for any "soft" or "dead" foot condition. A "soft foot" condition is comparable to a short leg on a four-legged table. To check for a "soft foot," make sure all four feet are securely bolted to the baseplate. With a dial indicator, check the rise of each foot as its holddown bolt is loosened. Retighten the holddown bolt after the rise is recorded, so that only one bolt is loose at a time. If one foot rises more than the other three, that foot is the "soft foot." For example, if one foot rises 0.005 inch while the other three rise only 0.002 inch, a 0.003-inch shim should be added to the "soft foot."
3. The holddown bolt holes should be checked for sufficient clearance to allow for movement during the alignment procedure.
4. Jacking bolts or other fixtures for moving the motor should be fabricated or procured.

5. The mounting brackets and extension bars used for the indicators should be constructed to minimize sag. Sag is the effect of gravity on the indicator extension bar and can greatly affect the accuracy of the readings when using the reverse indicator method or rim readings of the face and rim method. The sag of an indicator extension bar can be determined by securely attaching the extension bar to a section of rigid bar stock or a shaft mandrel. The rigid bar stock or mandrel can be supported and rotated by hand or between centers on a lathe. With the indicator bar positioned on top, zero the indicator and rotate the rigid bar stock 180 degrees. The indicator reading will be twice the actual amount of bar sag (figure 33). To correct alignment readings for sag, add twice the amount of bar sag to the bottom indicator reading. The bar sag is always expressed as a positive number, regardless of indicator convention.

---

**Important: The procedures described below for the face and rim and the reverse indicator alignment methods assume that movement towards the indicator moves the indicator needle in the positive direction, while movement away from the indicator moves the needle in the negative direction.**

---

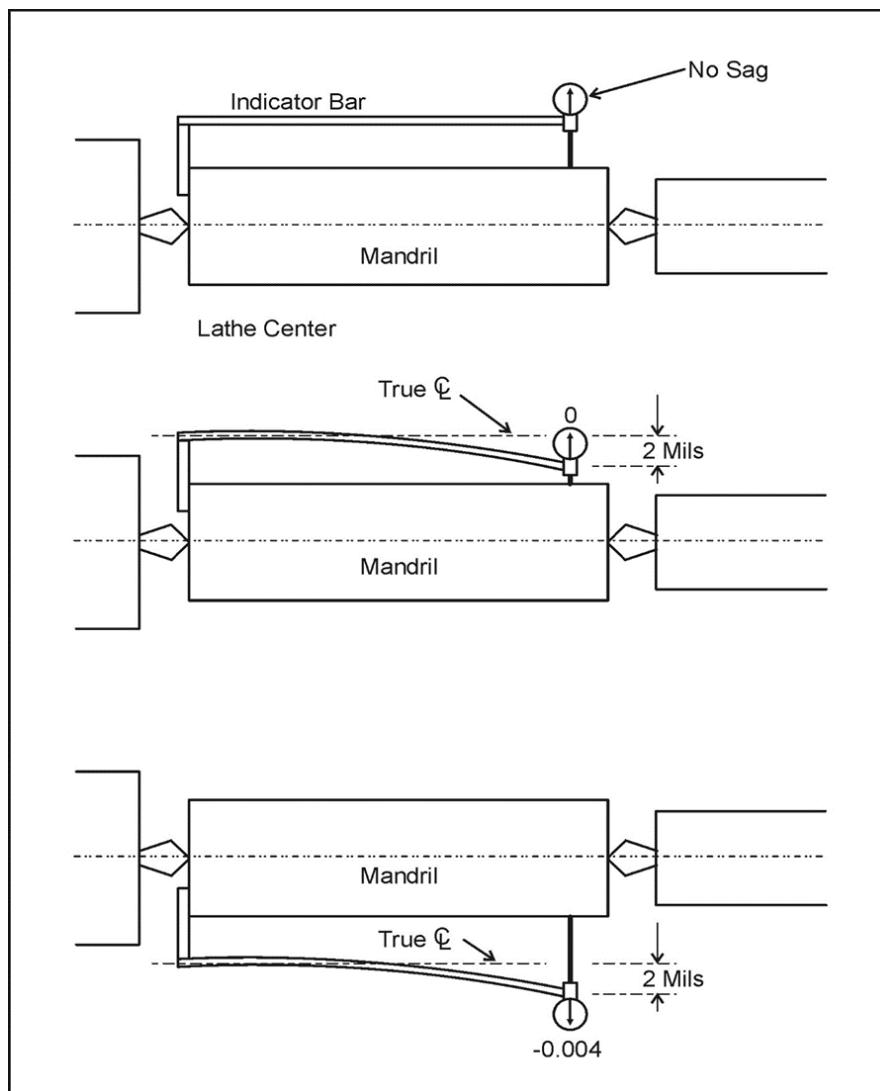

Figure 33.—Checking indicator bar for sag.

If the indicator used has the opposite sign convention, that is, movement towards the indicator moves the needle in the negative direction, enter the opposite sign than what is read onto the worksheet.

### 5.1.1 Face and Rim Alignment Method

The face and rim method of alignment uses a dial indicator attached to one of the coupling flanges to check for angular (dogleg) and parallel (offset) misalignment (figure 34). Indicator readings can be taken by rotating just one shaft. However, to compensate for an untrue surface on the face or rim of the coupling flange, both shafts should be rotated together in the direction of normal rotation. If it is not possible to rotate both shafts, the indicator base should be attached to the shaft that is rotated. The procedure is the same whether one or both shafts are rotated.

From the dial indicator readings and the dimensions of the motor, the amount each leg should be moved can be determined analytically. The Face and Rim Alignment Worksheet simplifies the required calculations. The following procedure uses the Face and Rim Worksheet (figure 35).

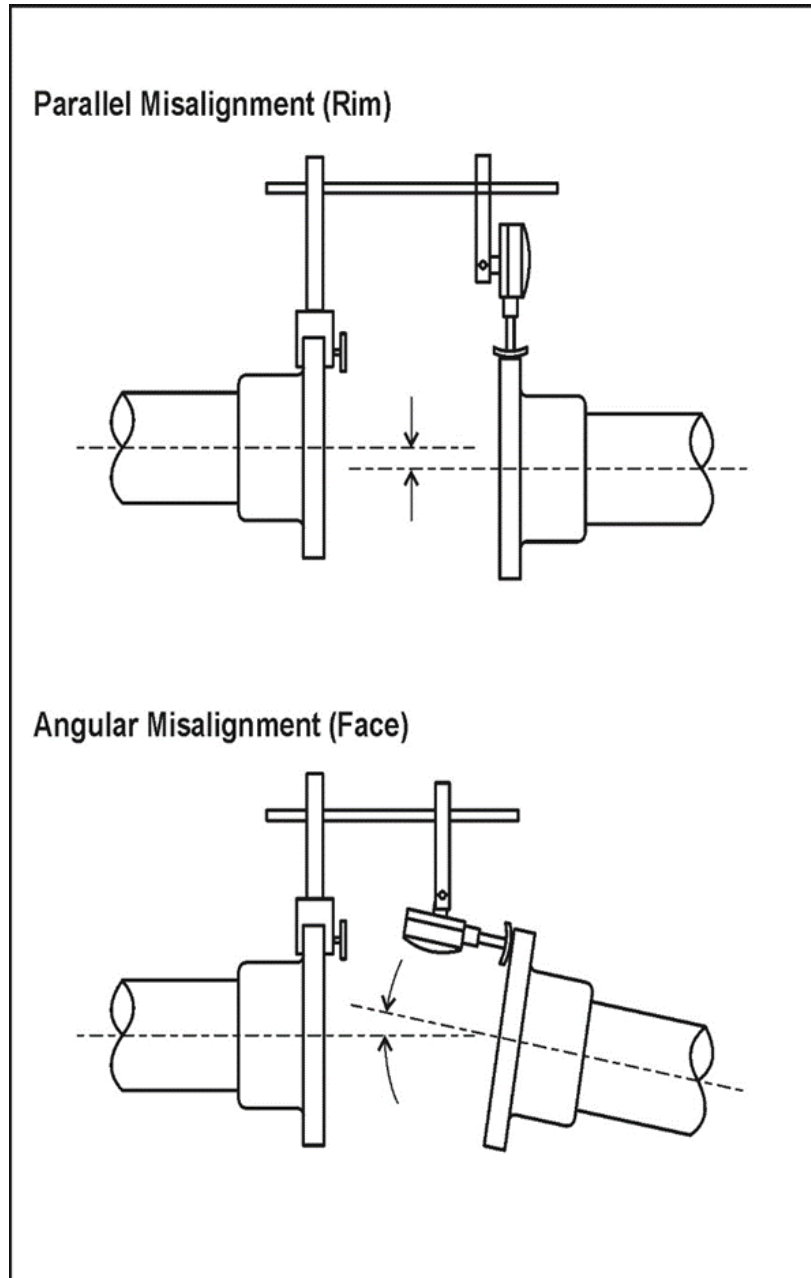

Figure 34.—Face and rim alignment method.

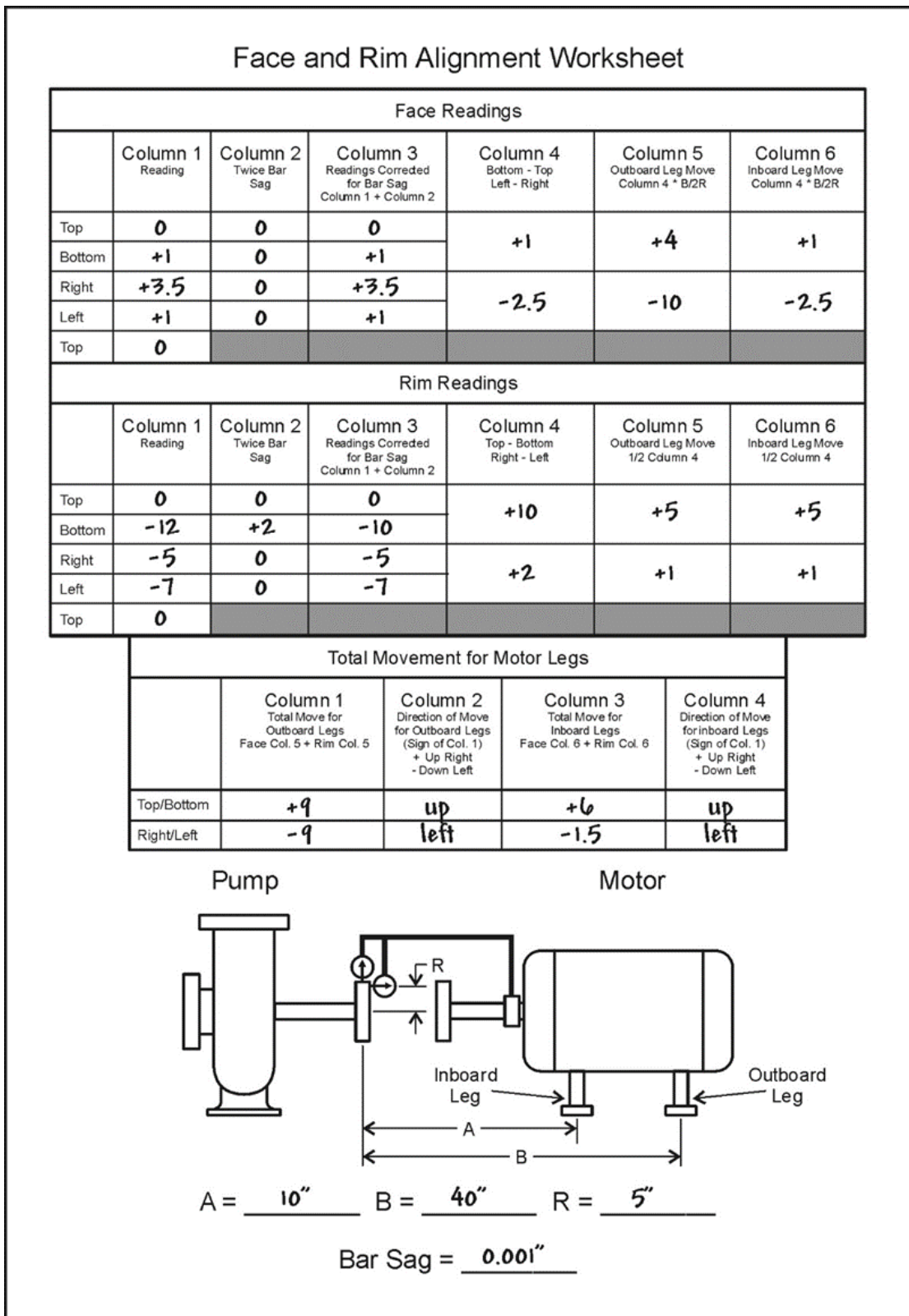

Figure 35.—Face and rim alignment worksheet example.

## Face Reading

1. Attach the indicator base to the motor coupling and adjust the indicator so that the button is resting near the outer edge of the pump coupling flange face. Measure the distance from the centerline of the indicator button to the shaft centerline and enter this value on the worksheet (figure 35) as Dimension R. Measure the horizontal distance from the face of the pump coupling flange to the center of the inboard leg and enter this value on the worksheet as the Dimension A. Measure the horizontal distance from the face of the pump coupling flange to the center of the outboard leg and enter this value on the worksheet as the Dimension B.
2. Rotate the shaft with the indicator so that the indicator is at the top or 12 o'clock position and zero the indicator.
3. Rotate both shafts, preferably in the direction of rotation during operation, and record the indicator readings at 90-degree intervals. For consistency, right and left readings should be designated for both shafts looking from the pump end towards the motor end. The indicator should read zero at 360 degrees. If it doesn't, zero the indicator and retake the readings.

## Rim Reading

1. Enter twice the actual amount of bar sag in Column 2, Bottom Reading in the worksheet as shown on figure 10. Attach the indicator base to the motor coupling flange and adjust the indicator so that the button is resting on the rim of the pump coupling flange.
2. Rotate the shaft with the indicator so that the indicator is at the top or 12 o'clock position and zero the indicator.
3. Rotate both shafts, preferably in the direction of rotation during operation, and record the indicator readings at 90-degree intervals. For consistency, right and left readings should be designated for both shafts looking from the pump end towards the motor end. The indicator should read zero at 360 degrees. If it doesn't, zero the indicator and retake the readings.

**Calculations.** With all the readings entered in Column 1 for both the Face and Rim readings, follow the directions in each column.

## Face and Rim Readings

### Column 1

These are the actual readings obtained from the dial indicator.

### Column 2

Enter twice the actual amount of bar sag for the fixture being used.

### Column 3

Add Columns 1 and 2. Column 2 is the effect of bar sag and is only added to the bottom reading of the Rim Readings.

### Column 4

*Face:* Subtract the top from the bottom and the right from the left from the corrected readings in Column 3.

*Rim:* Subtract the bottom from the top and the left from the right from the corrected readings in Column 3.

### Column 5

*Face:* This is the amount of movement required at the outboard legs to correct the angular misalignment. Multiply the value in Column 4 by the Dimension B, divided by two times the Dimension R.

*Rim:* This is the amount of movement required at the outboard legs to correct the parallel misalignment. Multiply the value in Column 4 by 1/2.

### Column 6

*Face:* This is the amount of movement required at the inboard leg to correct the angular misalignment. Multiply the value in Column 4 times the Dimension B, divided by two times the Dimension R.

*Rim:* This is the amount of movement required at the inboard leg to correct the parallel misalignment. Multiply the value in Column 4 by 1/2.

**Total Movement for Motor Legs.** This part of the table sums the required movement at each leg for parallel and angular misalignment to determine the total required movement.

### Column 1



Add the value in Face Column 5 to the value in Rim Column 5 to determine the total movement required for outboard legs.

### **Column 2**

Determine the direction of the required movement by the sign of the value in Column 1. A positive value means the motor should be moved up or right. A negative value means the motor should be moved down or left.

### **Column 3**

Add the value in Face Column 6 to the value in Rim Column 6 to determine the total movement required for inboard legs.

### **Column 4**

Determine the direction of the required movement by the sign of the value in Column 1. Positive values mean the motor should be moved up or right. Negative values mean the motor should be moved down or left.

## **5.1.2 Reverse Indicator Method**

The reverse indicator method of alignment can be used when it is possible to rotate both shafts. This method uses two dial indicators, one attached to each shaft, that take a reading on the opposite side of the other shaft. Indicator brackets are available that allow the indicator to be attached directly to the shaft, indicating off the indicator bar. This arrangement reduces bar sag and eliminates inaccuracies caused by a shaft's poor surface condition. From the data obtained by the reverse indicator method, it is possible to determine, either analytically or graphically, the movement or shims necessary to align the shafts. A graphical method is presented below using the Reverse Indicator Alignment Worksheet (figures 36).

### **Record Indicator Readings**

1. Attach indicator bars and indicators to shafts and position shafts so that the pump indicator, that is the indicator nearest the pump, is on top and the motor indicator is on the bottom. By increasing the span between the indicators, the accuracy of the readings usually can be increased, although bar sag may also increase. Zero both indicators at this position.
2. Rotate both shafts, preferably in the direction of normal rotation, and record the indicator readings at 90-degree intervals. For consistency, right and left readings should be designated for both shafts looking from the pump end towards the motor end. Both indicators should read zero at 360 degrees. If not, zero indicators and retake readings. It is

Alignment of Rotating Machinery

very important to record whether a reading is positive or negative and to keep track of each value's sign while performing the addition and subtraction in the following steps.

3. To correct for bar sag, add twice the actual amount of sag to the bottom readings.
4. Subtract the top reading from the corrected bottom reading and the left reading from the right reading; then divide the differences by 2. These values will be used for plotting the position of the shafts.

**Plot Data**

1. Two graphs will be needed: one for the horizontal plane (top view) and one for the vertical plane (side view) (figure 37). The horizontal scale of both graphs represents the horizontal distance from the plane of the pump indicator to the plane of the rear motor feet. Since the pump shaft will not be moved, it will be used as the horizontal reference in determining the position of the motor shaft. The vertical scale represents the misalignment of the motor shaft.

Reverse Indicator Alignment Worksheet

		Column 1 Actual Reading	Column 2 Correction to Bottom Reading for Bar Sag (Twice Actual Amount)	Column 3 Column 1 + Column 2	Column 4 Bottom - Top Right - Left	Column 5 0 1/2 Column 4 Distance of Motor Shaft Line from Pump Shaft Line	Column 6  Direction of Motor Shaft Line from Pump Shaft Line Circle Direction Corresponding to Sign of Value in Column 5
Pump Indicator	Bottom	12	+2	-10	-10	-5	+ Above - Below
	Top	0	0	0			
	Right	-5	0	-5	+2	+1	+ Left - Right
	Left	-7	0	-7			
	Top	0					
Motor Indicator	Bottom	0	+2	+2	+12	+6	+ Below - Above
	Top	-10	0	-10			
	Right	-4	0	-4	+2	+1	+ Right - Left
	Left	-6	0	-6			
	Top	0					

1. Zero indicators with pump indicator at top position and motor indicator at the bottom.  
(Pump indicator is indicator nearest pump)
2. Left and right for both indicators is determined by looking from pump end towards motor end.
3. The second top reading for the pump indicator and the second motor reading for the motor indicator should be zero. If not repeat all readings.

Indicator Bar Sag = 0.001" A = 16" B = 4" C = 40"

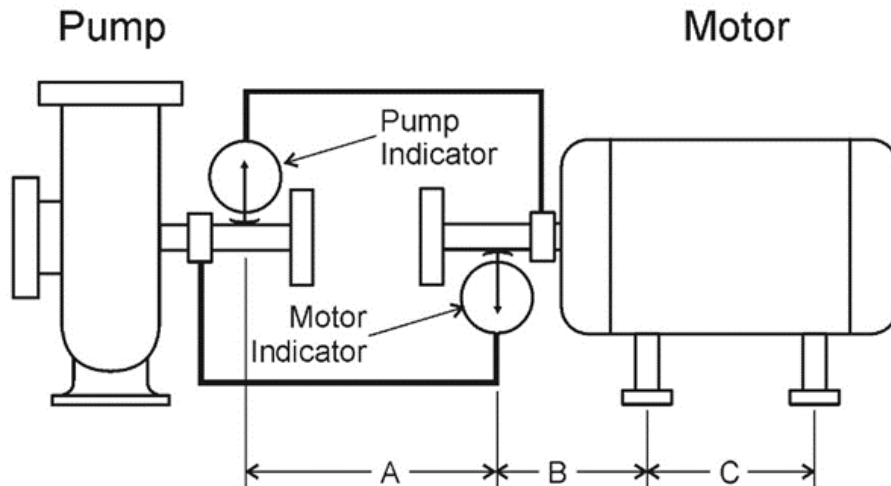

Figure 36.—Reverse indicator alignment worksheet (example).

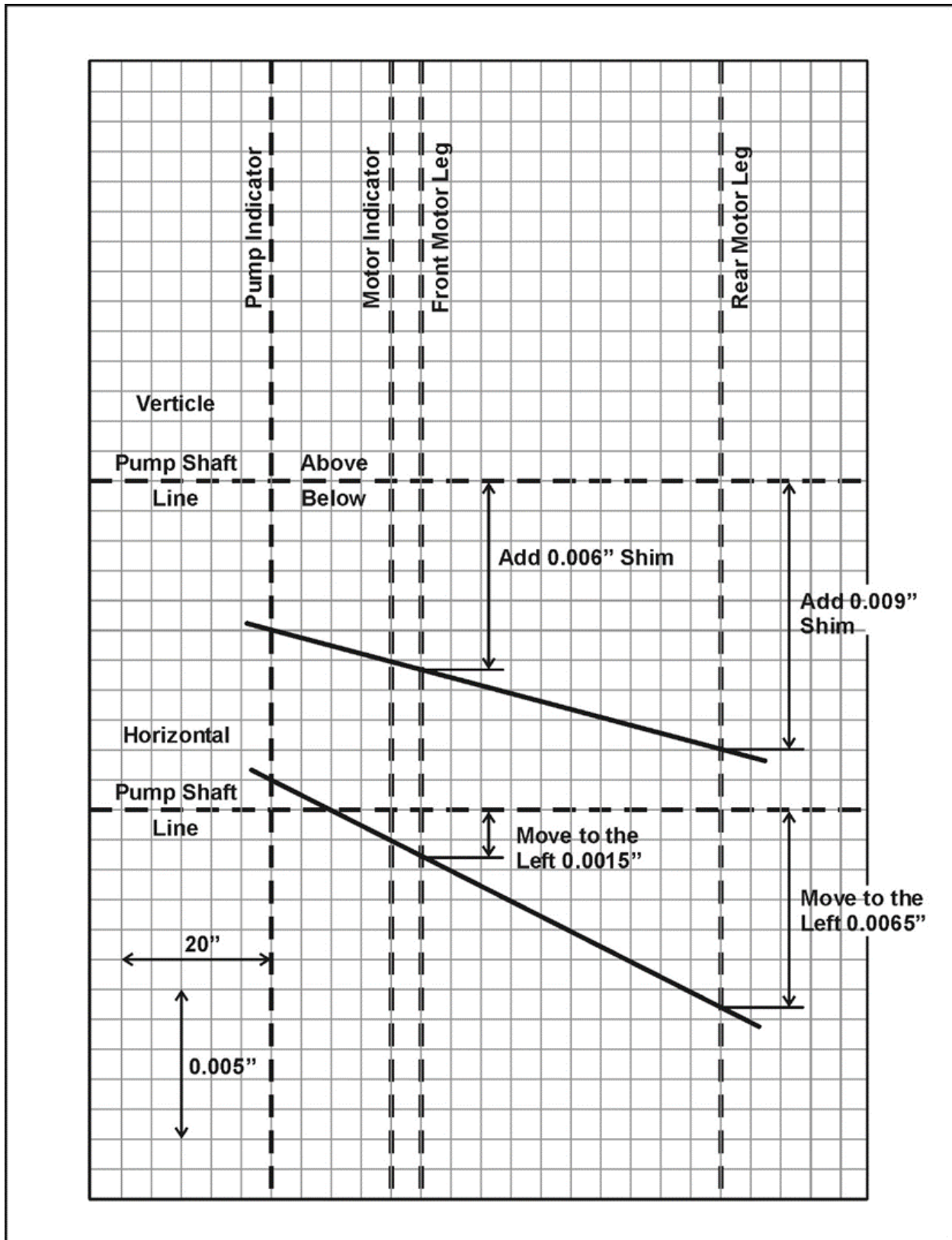

Figure 37.—Reverse indicator alignment plot.

2. Establish the horizontal scale, marking the relative position of both indicators and the front and rear motor feet with vertical lines. Draw two horizontal lines representing the pump shaft reference line for the horizontal and vertical planes. A vertical scale of 0.001 inch per division is usually satisfactory.
3. Plot the values from “Record Indicator Readings,” Step 4, above. These values represent the vertical distance from the pump shaft line to the motor shaft line at each of the indicator locations. The top-bottom readings are used in the vertical plane plot, and the left-right readings are used in the horizontal plane plot. The sign convention is different for the two indicators. If the values for the pump indicator are positive, the plot will be above and left of the pump shaft reference line. The plot will be below and right of the pump shaft reference line for negative motor indicator readings.
4. Draw a line from the pump indicator point through the motor indicator pump point extending to the rear motor feet line. This line represents the position of the motor shaft. The vertical distances from the motor shaft line to the pump shaft line at the two motor feet lines are the required movements of the motor feet to align the motor to the pump. On the vertical plane plot, these distances represent the required amount of shims to be added or removed. On the horizontal plane, these distances represent the amount of lateral movement required at the motor feet.
5. After any shimming or movement of the motor, repeat the readings and plot data to verify the alignment.

**This page intentionally left blank.**

# Appendix A

Blank Forms for Alignment of Vertical-Shaft Hydroelectric and Large  
Pump Units

FIST Volume 2-1

Alignment of Rotating Machinery – Appendix A

Unit Alignment Worksheet (Plumb Wires or Laser Systems)

Powerplant:		Unit:				Date:		
Notes:								
	Column 1	Column 2	Column 3	Column 4	Column 5	Column 6	Column 7	Column 8
	Actual Readings	Mathematical amount to be added to Col. 1 to theoretically move all wires an equal distance from center of shaft	Total Column 1 plus Column 2	Difference N&S E&W	Half Column 4 (Out of plumb between top and bottom reading)	Direction bottom of shaft is out of plumb. (Direction of smaller number in Column 3)	Total N+S and E+W from Column 3	Out of roundness or inaccuracy of readings (N+S) – (E+W). Should be less than 0.002
First Reading Elevation	North							
	South							
	East							
	West							
Second Reading Elevation	North							
	South							
	East							
	West							
Third Reading Elevation	North							
	South							
	East							
	West							
Fourth Reading Elevation	North							
	South							
	East							
	West							

(FIST 007) 08/02/2016

NEW RELEASE







180° Position	First Reading Elevation	North									
		South									
		East									
		West									
	Fourth Reading Elevation	North									
		South									
		East									
		West									
270° Position	First Reading Elevation	North									
		South									
		East									
		West									
	Fourth Reading Elevation	North									
		South									
		East									
		West									

**Unit Runout Data and Runout Plot (Wire or Laser System)**

Powerplant:		Unit:		Date:	
Notes:					
		Column A	Column B	Column C	Column D
		Multiplier to determine total out of plumb (A+E)/E	Values of Column 5 of runout worksheet	Total out of plumb (Column A × Column B)	Direction Shaft is out of Plumb (Column 6)
0° Position	North-South				
	East-West				
90° Position	North-South				
	East-West				
180° Position	North-South				
	East-West				
270° Position	North-South				
	East-West				

FIST Volume 2-1  
Alignment of Rotating Machinery – Appendix A

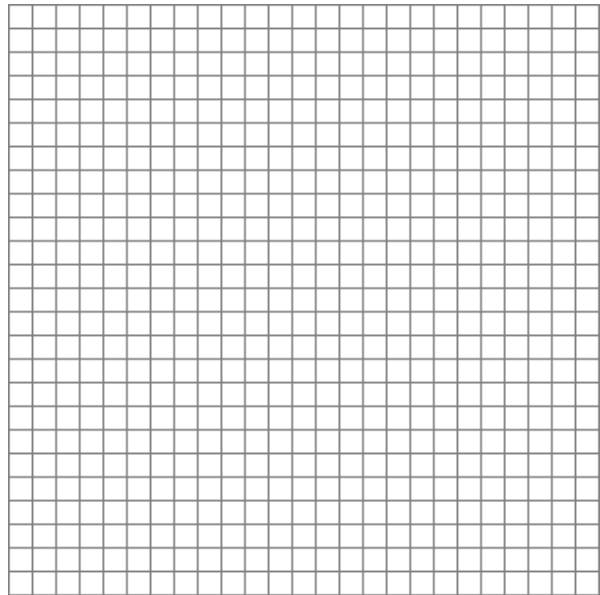
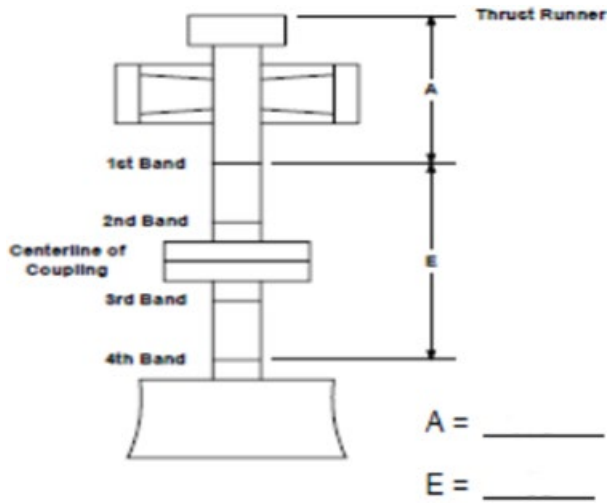

Unit Alignment Worksheet (Precision Level)

Calculation of Out of Plumb of Center of Runout							
	Column 1	Column 2	Column 3	Column 4	Column 5	Column 6	Column 7
	Level reading	Enter 0.004848 if reading in arc-sec, enter 1 if reading in mils/in	Column 1 × Column 2	Difference N-S E-W	One-half of Column 4	Total N+S, E+W from Column 3	Inaccuracy (N+S) – (E+W)
North							
South							
East							
West							

Points for Plotting Center of Runout and Shaft Centerline					
		Out of plumb of center of runout in mils/inch	Coordinates for Plotting of center of runout	Coordinates of center of runout from Static Runout Plot	Coordinates of Shaft Centerline
		Column A Distance from UGB Indicator	Column B Values from Column 5	Column C Column A × Column B	Column D Coordinates of Center of Runout from Static Runout Plot
		Column E Coordinates of Shaft Centerline Column C – Column D			
LGB	North-South	(A)			
	East-West	(A)			
TGB	North-South	(B)			
	East-West	(C)			

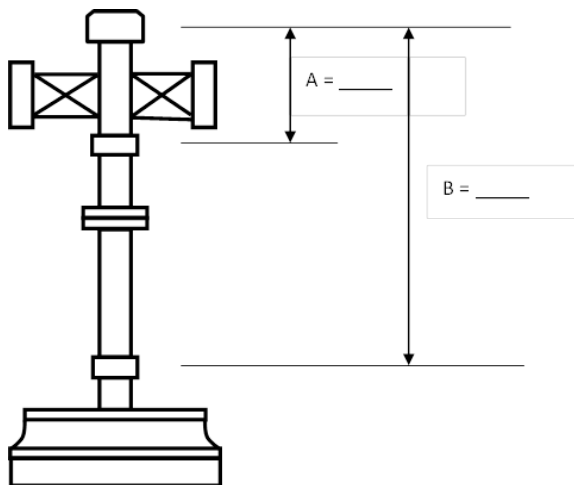



## **Appendix B**

Blank Forms for Alignment of Horizontal Shaft Hydroelectric and Large Pump Units

Reserved; under development.

**This page intentionally left blank.**



## **Appendix C**

Blank Forms for Alignment of Vertical Shaft Auxiliary Equipment

Reserved; under development.

**This page intentionally left blank.**

# Appendix D

Blank Forms for Alignment of Horizontal Shaft Auxiliary Equipment

### Face and Rim Alignment Worksheet

Face Readings						
	Column 1 Reading	Column 2 Twice Bar Sag	Column 3 Readings Corrected for Bar Sag Column 1 + Column 2	Column 4 Bottom - Top Left - Right	Column 5 Outboard Leg Move Column 4 * B/2R	Column 6 Inboard Leg Move Column 4 * B/2R
Top						
Bottom						
Right						
Left						
Top						
Rim Readings						
	Column 1 Reading	Column 2 Twice Bar Sag	Column 3 Readings Corrected for Bar Sag Column 1 + Column 2	Column 4 Bottom - Top Left - Right	Column 5 Outboard Leg Move Column 4 * B/2R	Column 6 Inboard Leg Move Column 4 * B/2R
Top						
Bottom						
Right						
Left						
Top						
Total Movement for Moter Legs						
	Column 1 Total Move for Outboard Legs Face Col. 5 + Rim Col. 5	Column 2 Direction of Move for Outboard Legs (Sign of Col. 1) + Up Right - Down Left	Column 3 Total Move for Inboard Legs Face Col. 6 + Col. 5	Column 4 Direction of Move for Inboard Legs (Sign of Col. 1) + Up Right - Down Left		
Top/Bottom						
Right/Left						

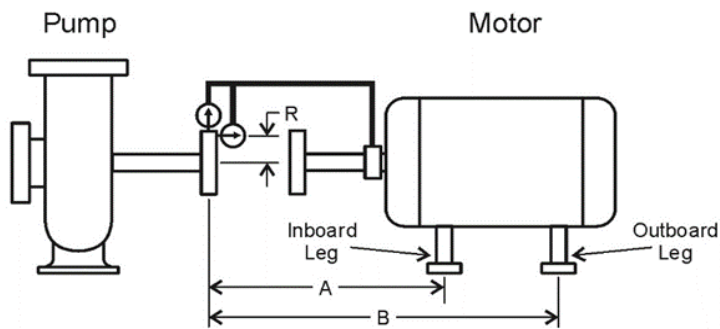

A = \_\_\_\_\_    B = \_\_\_\_\_    R = \_\_\_\_\_  
 Bar Sag = \_\_\_\_\_

### Reverse Indicator Alignment Worksheet

		Column 1 Actual Reading	Column 2 Correction to Bottom Reading for Bar Sag (Twice Actual Amount)	Column 3 Column 1 + Column 2	Column 4 Bottom - Top Right - Left	Column 5 0 1/2 Column 4 Distance of Motor Shaft Line from Pump Shaft Line	Column 6 Direction of Motor Shaft Line from Pump Shaft Line Circle Direction Corresponding to Sign of Value in Column 5
Pump Indicator	Bottom						+ Above - Below
	Top	0	0				
	Right		0				+ Left - Right
	Left		0				
	Top						
Motor Indicator	Bottom	0					+ Below - Above
	Top		0				
	Right		0				+ Right - Left
	Left		0				
	Top						

1. Zero indicators with pump indicator at top position and motor indicator at the bottom.  
(Pump indicator is indicator nearest pump)
2. Left and right for both indicators is determined by looking from pump end towards motor end.
3. The second top reading for the pump indicator and the second motor reading for the motor indicator should be zero. If not repeat all readings.

Indicator Bar Sag = \_\_\_\_\_ A = \_\_\_\_\_ B = \_\_\_\_\_ C = \_\_\_\_\_

